

Silicon NPN Power Transistors

2SD1556

DESCRIPTION

- With TO-3P(H)IS package
- Built-in damper diode
- High voltage ,high speed
- Low collector saturation voltage

APPLICATIONS

- For color TV horizontal output applications

PINNING

PIN	DESCRIPTION
1	Base
2	Collector
3	Emitter

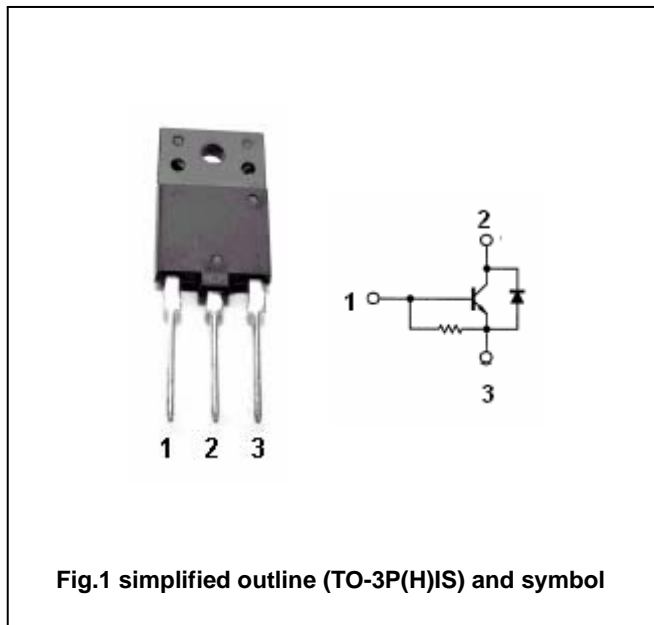

Fig.1 simplified outline (TO-3P(H)IS) and symbol

Absolute maximum ratings (Ta=25)

SYMBOL	PARAMETER	CONDITIONS	VALUE	UNIT
V_{CBO}	Collector-base voltage	Open emitter	1500	V
V_{CEO}	Collector-emitter voltage	Open base	600	V
V_{EBO}	Emitter-base voltage	Open collector	5	V
I_C	Collector current		6	A
I_B	Base current		3	A
P_C	Collector power dissipation		50	W
T_j	Junction temperature		150	
T_{stg}	Storage temperature		-55~150	

Silicon NPN Power Transistors

2SD1556

CHARACTERISTICS

T_j=25 unless otherwise specified

SYMBOL	PARAMETER	CONDITIONS	MIN	TYP.	MAX	UNIT
V _{(BR)EBO}	Emitter-base breakdown voltage	I _E =200mA, I _C =0	5			V
V _{CEsat}	Collector-emitter saturation voltage	I _C =5A; I _B =1A		3.0	5.0	V
V _{BEsat}	Base-emitter saturation voltage	I _C =5A; I _B =1A			1.5	V
I _{CBO}	Collector cut-off current	V _{CB} =500V; I _E =0			10	μA
h _{FE}	DC current gain	I _C =1A; V _{CE} =5V	8			
f _T	Transition frequency	I _C =0.1A; V _{CE} =10V		3		MHz
C _{OB}	Collector output capacitance	I _E =0; V _{CB} =10V; f=1MHz		165		pF
V _F	Diode forward voltage	I _F =6A		1.6	2.0	V
t _f	Fall time	I _{CP} =5A; I _{B1(end)} =1A		0.5	1.0	μs

Silicon NPN Power Transistors

2SD1556

PACKAGE OUTLINE

