

The BA6435S is an IC that is used for driving video cassette recorder capstan motors.

## Features

- available in a SDIP-M24 package
- supply voltage range 4 ~ 6 V (control block) and 3 ~ 23 V (output block)
- power dissipation (2000 mW)
- maximum output current up to 1500 mA
- three-phase full-wave pseudo linear driving system
- built-in thermal shutdown circuit (TSD)
- forward and reverse control
- built-in reversing brake (based on detection of rotation direction)
- regulated voltage supply for Hall-effect elements
- torque ripple cancelling circuit (to reduce wow and flutter)
- output transistor (H side, L side) saturation prevention circuit
- provided with a regenerative braking system and motor power supply control terminal

## Applications

- video cassette recorder capstan motors

## Dimensions (Units : mm)

### BA6435S (SDIP-M24)

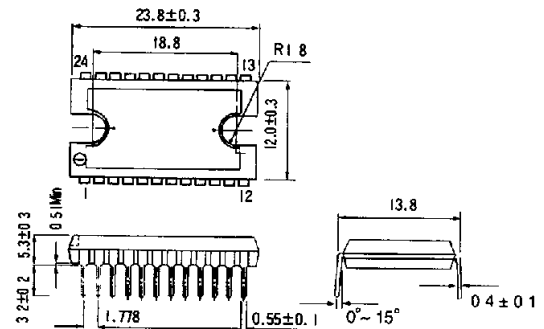

Block diagram

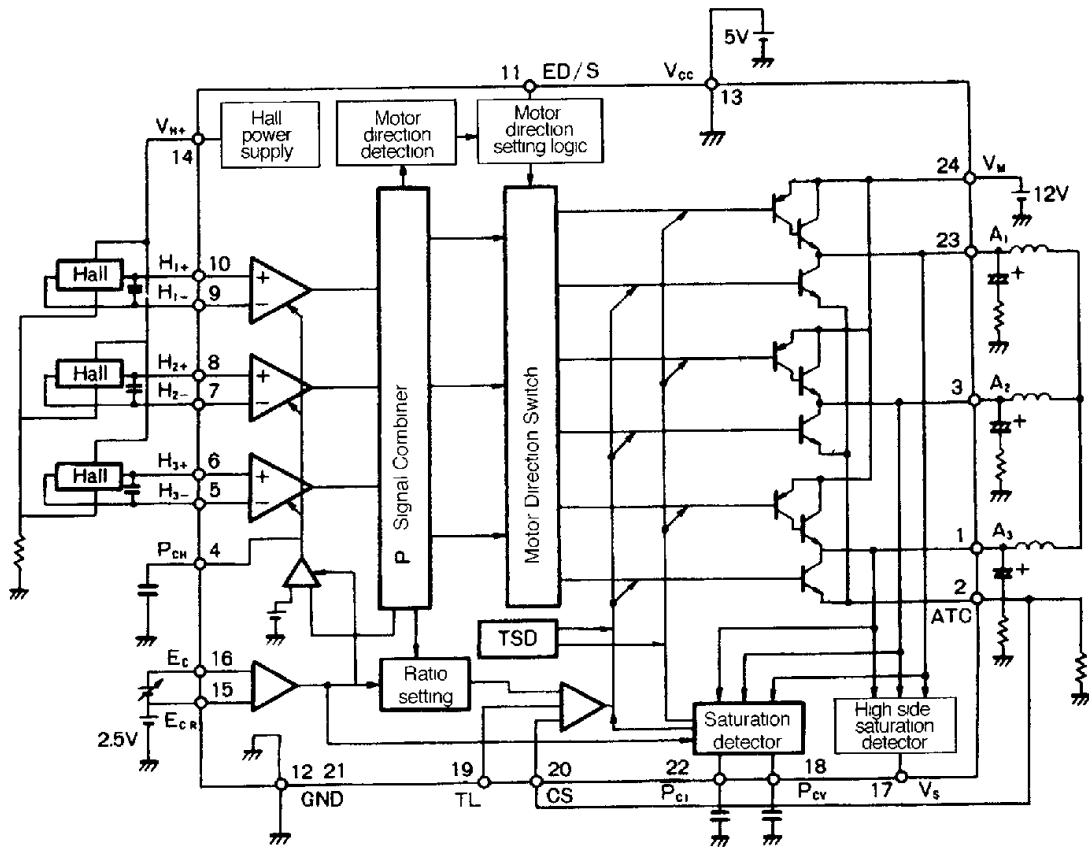

Absolute maximum ratings ( $T_a = 25^\circ\text{C}$ )

Parameter	Symbol	Limits	Unit	Conditions
Power supply voltage	$V_{CC}$	7	V	
	$V_M$	24		
Power dissipation	$P_d$	2000	mW	Reduce power by 16 mW for each degree above $25^\circ\text{C}$ .
Motor drive current	$I_{Opeak}$	1500	mA	The output current must not exceed the maximum $P_d$ or ASO ratings.
Operating temperature	$T_{opr}$	$-20 \sim +75$	$^\circ\text{C}$	
Storage temperature	$T_{stg}$	$-40 \sim +150$	$^\circ\text{C}$	

Electrical characteristics (unless otherwise noted,  $T_a = 25^\circ\text{C}$ ,  $V_{CC} = 5\text{ V}$ ,  $V_M = 12\text{ V}$ )

Parameter	Symbol	Min	Typical	Max	Unit	Conditions
Power supply voltage	$V_M$	3		23	V	Minimum 6 V for the TSD circuit
	$V_{CC}$	4		6		
Input/output gain	$G_{IO}$	0.29	0.32	0.35		Inputs L, L, H $E_C = 2.3\text{ V} \rightarrow 2.2\text{ V}$
Hall element supply voltage	$V_{H^+}$	3.3	3.6	3.8	V	$I_H = 15\text{ mA}$
Torque command input current	$V_{RCC}$	4.5	6.3	8.1	%	Inputs from L, L, H to L, M, H
High level voltage	$V_{OH}$	1.1	1.5	1.9	V	$I_O = 0.8\text{ A}$
Low level voltage	$V_{OL}$	0.95	1.3	1.65	V	$I_O = 0.8\text{ A}$
Saturation detect output gain	$G_{VS}$	1.7	2.0	2.3		

## Circuit operation

### Pseudo-linear output and torque ripple cancellation

The IC generates a trapezoidal (pseudo-linear) output current waveform, the phase of which leads that of the Hall input voltage by 30 degrees, see Figure 1.

A trapezoidal output current, however, would create a zero magnetic field at the crest of each period of the three phase windings. This torque ripple can cause an irregular rotation of the motor. To prevent this, the output waveform is obtained by superimposing a triangular waveform on the trapezoidal wave (see Figure 2). This process is called torque ripple cancellation.

**Figure 1 Hall input and output current waveforms**

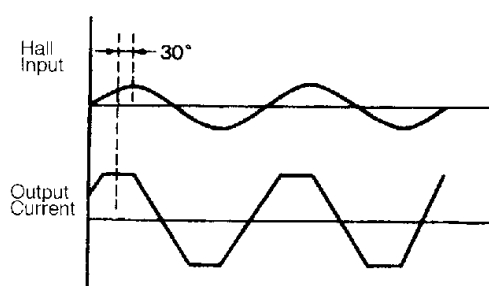

**Figure 2 Torque ripple cancellation waveform**

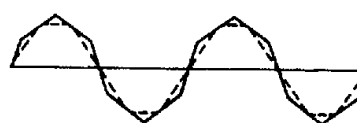

### Reverse rotation braking

The motor driver current is controlled by applying a voltage across pins 15 and 16, the torque control pins.

**Figure 3 Motor torque control**

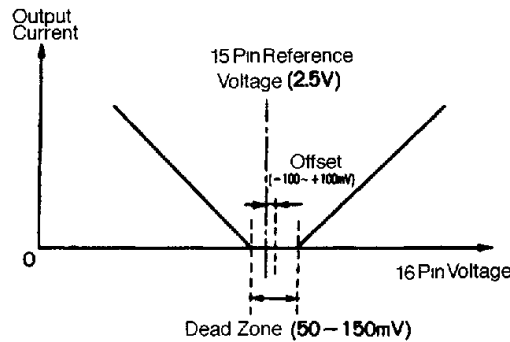

These pins are the inputs to a differential amplifier. Pin 15 is connected to the reference side at a voltage between 2.3 and 3.0 V (2.5 V is recommended).

With the motor running normally in a clockwise direction, pin 16 is given a negative potential with respect to the reference voltage on pin 15.

If pin 16 is taken positive, the differential amplifier detects the voltage on pin 16 when it crosses that of pin 15. This detection activates the motor direction change circuit.

The motor direction change circuit sends an input to the motor direction setting logic to indicate that the motor has changed direction. This causes a braking torque corresponding to the magnitude of the voltage on pin 16 to be applied to the motor, which quickly reduces its speed.

At the same time, the potential on pin 16 is shifted from positive back to the reference potential, to bring the motor to a smooth stop.

**Output current sensing and torque limitation**

Pin 2 is the ground terminal for the output stage. To sense the output current, a small resistor (a value of 0.5 Ω is recommended) can be connected between pin 2 and ground. The output current is sensed by applying the voltage developed across this resistor to pin 20 as a feedback voltage.

The output current can be limited by applying a voltage to pin 19. The limit is applied when pin 19 reaches the same potential as pin 20. The output current ( $I_{Max}$ ) is given by the formula:

$$I_{Max} = \frac{V_{Pin19}}{R_{Pin2}}$$

where  $R_{Pin2}$  is value of the resistor connected between pin 2 and ground  
 $V_{Pin19}$  is the voltage applied to pin 19.

**Motor supply voltage control**

Almost all of the power dissipated by the IC is dissipated between the collectors and emitters of the output stage transistors. More power is consumed as the collector-to-emitter voltage increases and as the output current increases.

The output transistor C-E voltage is equal to the difference between the supply voltage and the voltage applied to the motor. Therefore, if the supply voltage is fixed, when the drive current decreases, the voltage across the motor decreases, and the C-E voltage must increase by the same amount.

Therefore, to improve the efficiency of the driver (and to prevent the power rating of the IC being exceeded), the supply voltage must be varied in response to changes in the output current. The supply voltage is decreased at low current and increased at high current so that no unnecessary output transistor C-E voltage is applied, and no unnecessary power is dissipated by the transistors.

The supply voltage controller monitors the C-E voltage of the high-side output transistors and outputs, at pin 19, a supply voltage control signal which corresponds to the input voltage at pin 16. This signal is used to control the external motor supply voltage.

The reason this control signal varies with respect to the input voltage on pin 16 is that the minimum voltage required by the output transistors ( $V_{CE(sat)}$ ) depends on the output current.

**Figure 4 Motor supply voltage control**

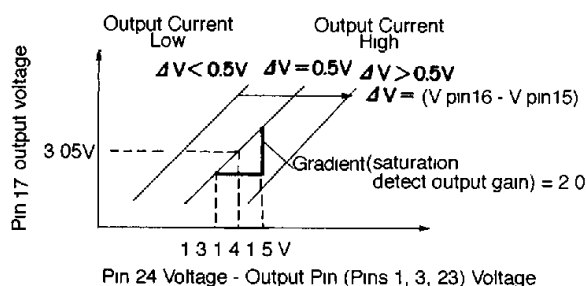

**Figure 5 Output equivalent circuit**

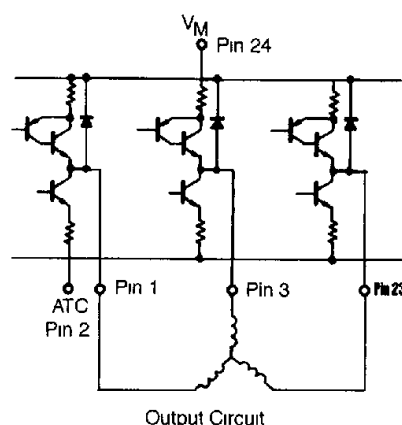

#### Forced stop (pin 4)

This function turns all high side output transistors off, and all low side transistors on. It operates when pin 4 goes at least 1.5 V positive with respect to pin 2, and when the IC goes to the run state at potentials of 0.7 V or less with respect to GND.

#### Motor direction control (pin 11)

Forward: < 0.9 V  
 Stop: 1.3 ~ 3.0 V  
 Reverse: > 3.5 V

In the stop state, all output transistors (high and low sides) are off, putting the outputs in a high impedance state. The capacitors on pins 18 and 22 are used to prevent oscillation.

**Output transistor saturation prevention**

This circuit monitors the output voltage and confines the transistor output so that it does not reach saturation.

Operating the transistors in the linear portion of their characteristic curves provides good control from low currents to high currents. This results in good torque characteristics even during adverse conditions such as overload.

**Figure 6 Transistor high level output voltage Figure 7 Transistor low level output voltage**

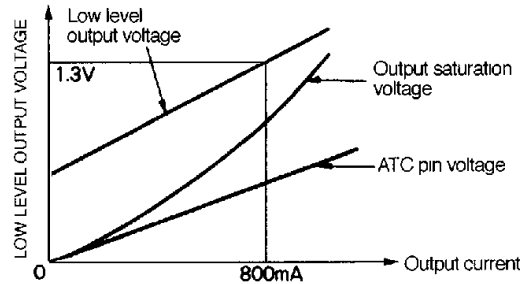
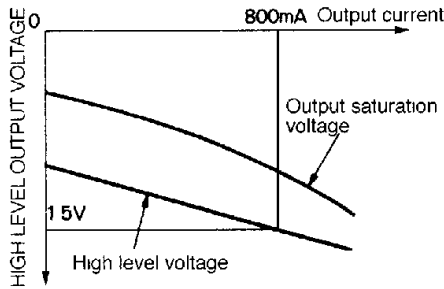

**Precautions for use**

**Thermal shutdown (TSD)**

The BA6435S has two thermal shutdown circuits (TSD1 and TSD2) to protect the IC. The nominal shutdown temperatures for the two circuits are as follows:

- TSD1: 175°C
- TSD2: 215°C

If the junction temperature rises to the TSD1 setpoint, the pin 1, 3, and 23 outputs are set to the open state. TSD1 protects the IC from overheating caused by high output current, or shorting the outputs. It does not protect the IC against overheating due to high internal IC currents caused by external factors (such as pin-to-pin shorts).

If the junction temperature rises to the TSD2 setpoint, the high and low side output transistors are turned on, and the internal resistance between the motor power supply input (pin 24) and the output ground pin (pin 2) drops to less than 3 Ω. The motor power supply current ( $I_M$ ) is then given by the equation:

$$I_M = \frac{V_M}{R_M + R_{Pin2} + 3}$$

where  $V_M$  is the motor power supply voltage  
 $R_M$  is the motor power supply output resistance  
 $R_{Pin2}$  is the pin 2 resistance.

In the application circuit design, a circuit breaker that opens at less than  $I_M$  must always be inserted between the motor power supply and pin 24. In the BA6435S, these TSD circuits require  $V_M$  voltages of > 6 V to operate.

Electrical characteristic curves

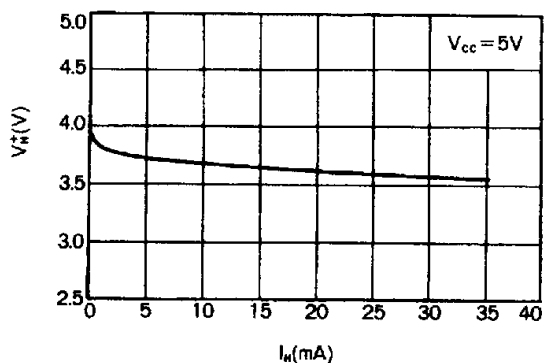

Figure 8

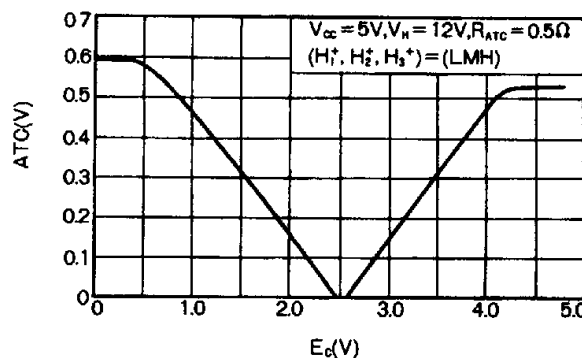

Figure 9

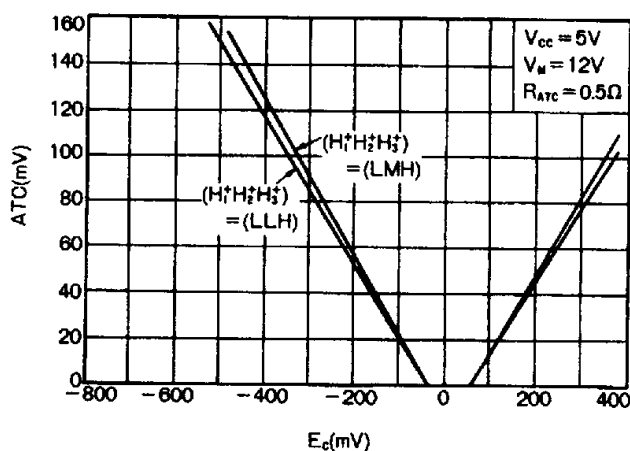

Figure 10

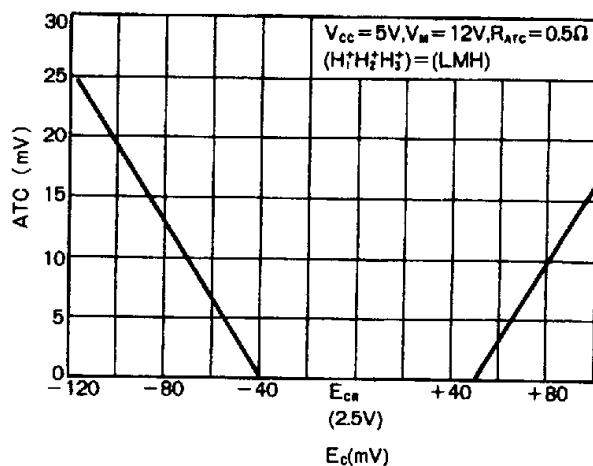

Figure 11

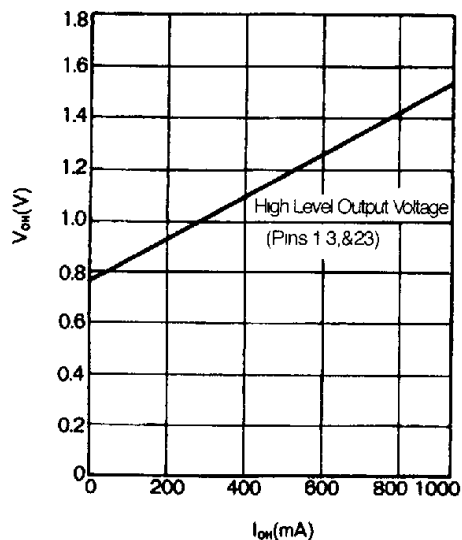

Figure 12

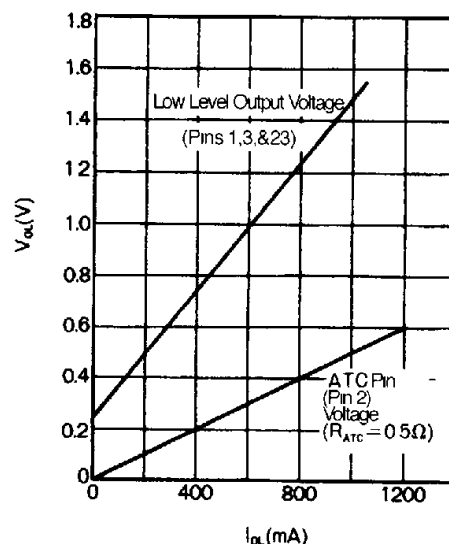

Figure 13

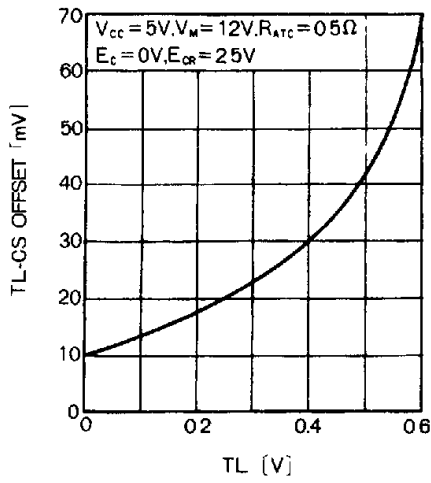

Figure 14

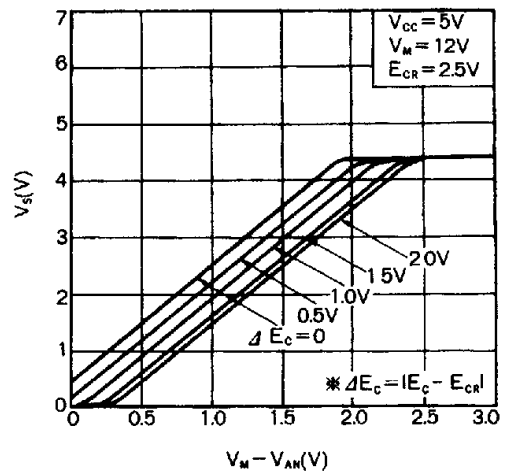

Figure 15

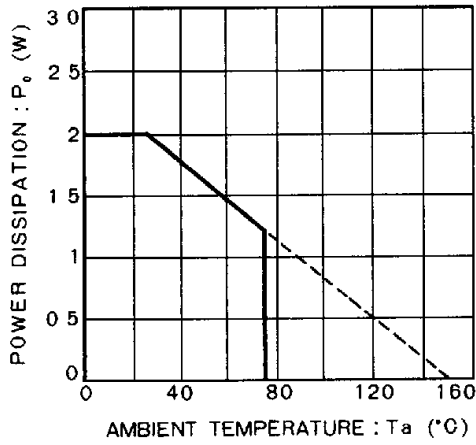

Figure 16