

Silicon NPN Darlington Power Transistor

BU920T

DESCRIPTION

- High Voltage
- DARLINGTON

APPLICATIONS

- Designed for automotive ignition applications and inverter circuits for motor control.

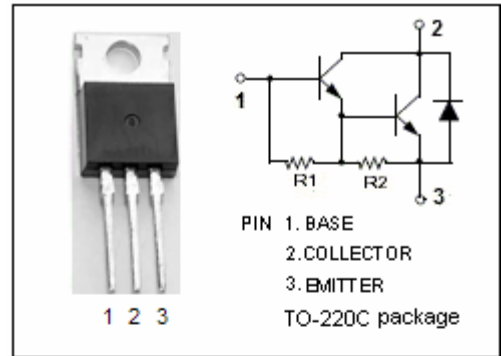

ABSOLUTE MAXIMUM RATINGS (Ta=25)

SYMBOL	PARAMETER	VALUE	UNIT
V _{CES}	Collector-Emitter Voltage V _{BE} = 0	400	V
V _{CEO}	Collector-Emitter Voltage	350	V
V _{EBO}	Emitter-Base Voltage	5	V
I _C	Collector Current	10	A
I _{CM}	Collector Current-peak	15	A
I _B	Base Current	5	A
P _C	Collector Power Dissipation @T _C =25	105	W
T _j	Junction Temperature	150	
T _{stg}	Storage Temperature Range	-65~150	

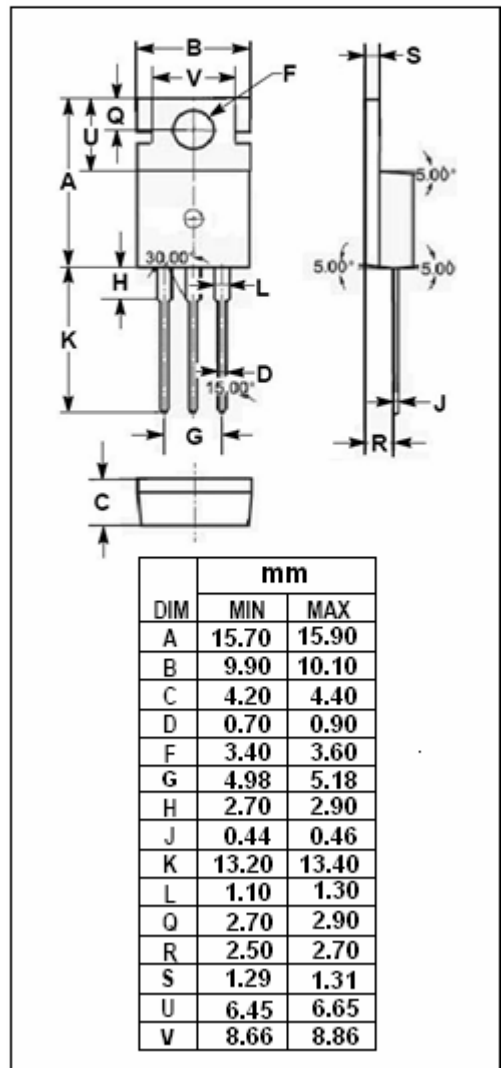

THERMAL CHARACTERISTICS

SYMBOL	PARAMETER	MAX	UNIT
R _{th j-c}	Thermal Resistance, Junction to Case	1.2	/W

Silicon NPN Darlington Power Transistor

BU920T

ELECTRICAL CHARACTERISTICS

 $T_C=25$ unless otherwise specified

SYMBOL	PARAMETER	CONDITIONS	MIN	TYP.	MAX	UNIT
$V_{CEO(SUS)}$	Collector-Emitter Sustaining Voltage	$I_C=0.1A; I_B=0$	350			V
$V_{CE(sat)-1}$	Collector-Emitter Saturation Voltage	$I_C=5A; I_B=50mA$			1.8	V
$V_{CE(sat)-2}$	Collector-Emitter Saturation Voltage	$I_C=7A; I_B=140mA$			1.8	V
$V_{BE(sat)-1}$	Base-Emitter Saturation Voltage	$I_C=5A; I_B=50mA$			2.2	V
$V_{BE(sat)-2}$	Base-Emitter Saturation Voltage	$I_C=7A; I_B=140mA$			2.5	V
I_{CES}	Collector Cutoff Current	$V_{CE}=400V; V_{BE}=0$ $V_{CE}=400V; V_{BE}=0; T_j=125$			0.25 0.5	mA
I_{CEO}	Collector Cutoff Current	$V_{CE}=350V; I_B=0$			0.25	mA
I_{EBO}	Emitter Cutoff Current	$V_{EB}=5V; I_C=0$			50	mA
V_{ECF}	C-E Diode Forward Voltage	$I_F=7A$			2.5	V