

# HA17723/F/P

## Precision Voltage Regulator

# HITACHI

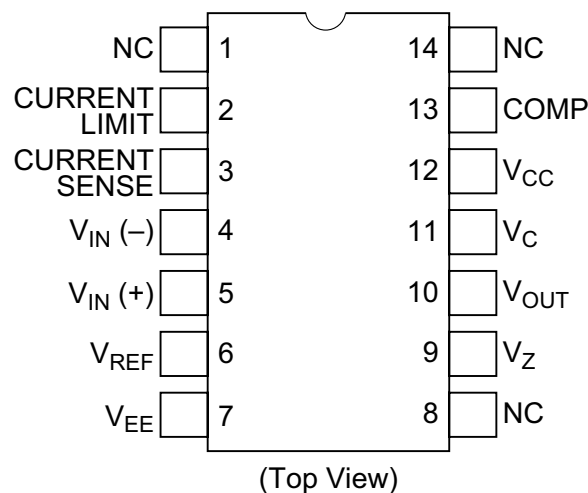
### Description

The HA17723 high-accuracy general-purpose voltage regulator features a very low stand-by current, (quiescent current) a low temperature drift, and high ripple rejection ratio. If you need over than 150mA output current, adding external PNP or NPN transistor. This voltage regulator is suitable for various applications, for example, series or parallel regulator, switching regulator.

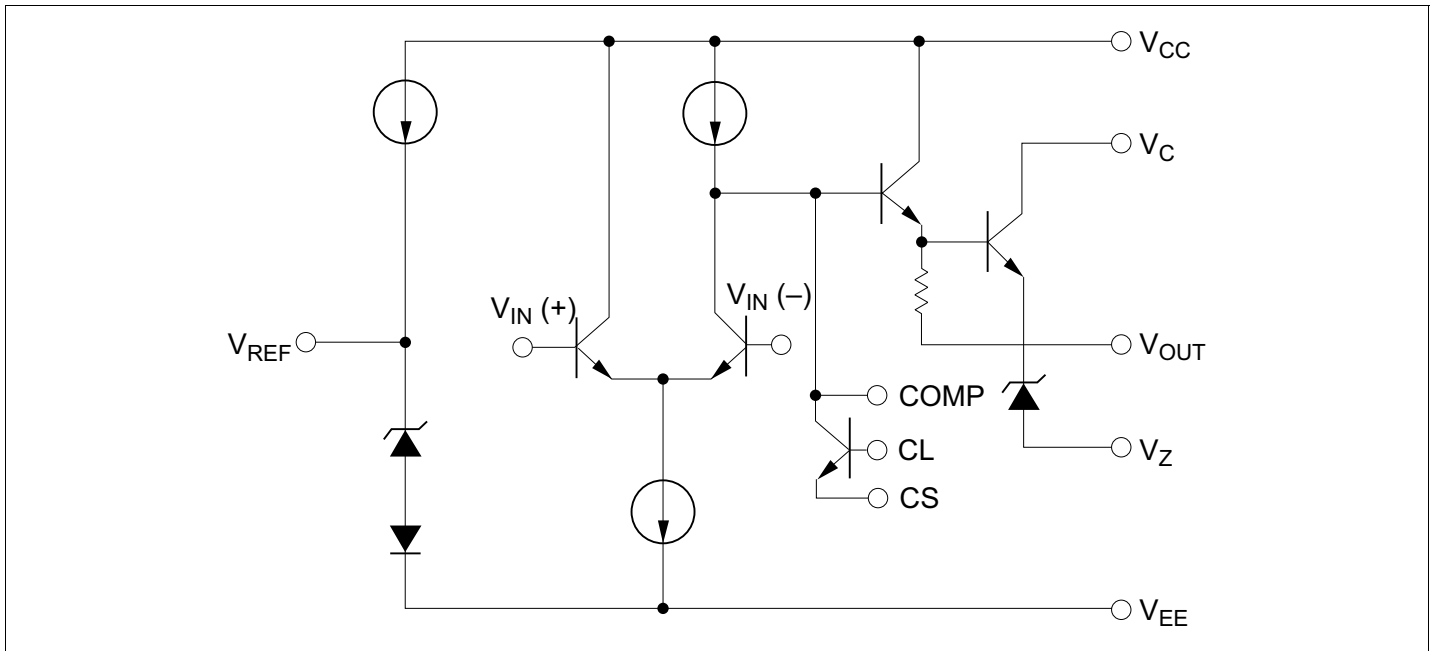
### Ordering Information

Type No.	Application	Package
HA17723	Commercial use	DP-14
HA17723F		FP-14DA
HA17723P	Industrial use	DP-14

### Pin Arrangement



Circuit Schematic



**Absolute Maximum Ratings** (Ta = 25°C)

Item	Symbol	HA17723/P	HA17723F	Unit
Supply voltage	VCC	40	40	V
Input/Output voltage differential	Vdiff (IN-O)	40	40	V
Differential input voltage	V <sub>IN</sub> (diff)	±5	±5	V
Maximum output current	I <sub>OUT</sub>	150	150	mA
Current from VREF	I <sub>REF</sub>	15	15	mA
Power dissipation	P <sub>T</sub>	830 (Note 1)	625 (Note 2)	mW
Operating temperature	Topr	0 to +70 / -20 to +75	0 to +70	°C
Storage temperature	Tstg	-55 to +125	-55 to +125	°C

Notes: 1. Above 25°C derate by 8.3mW/°C

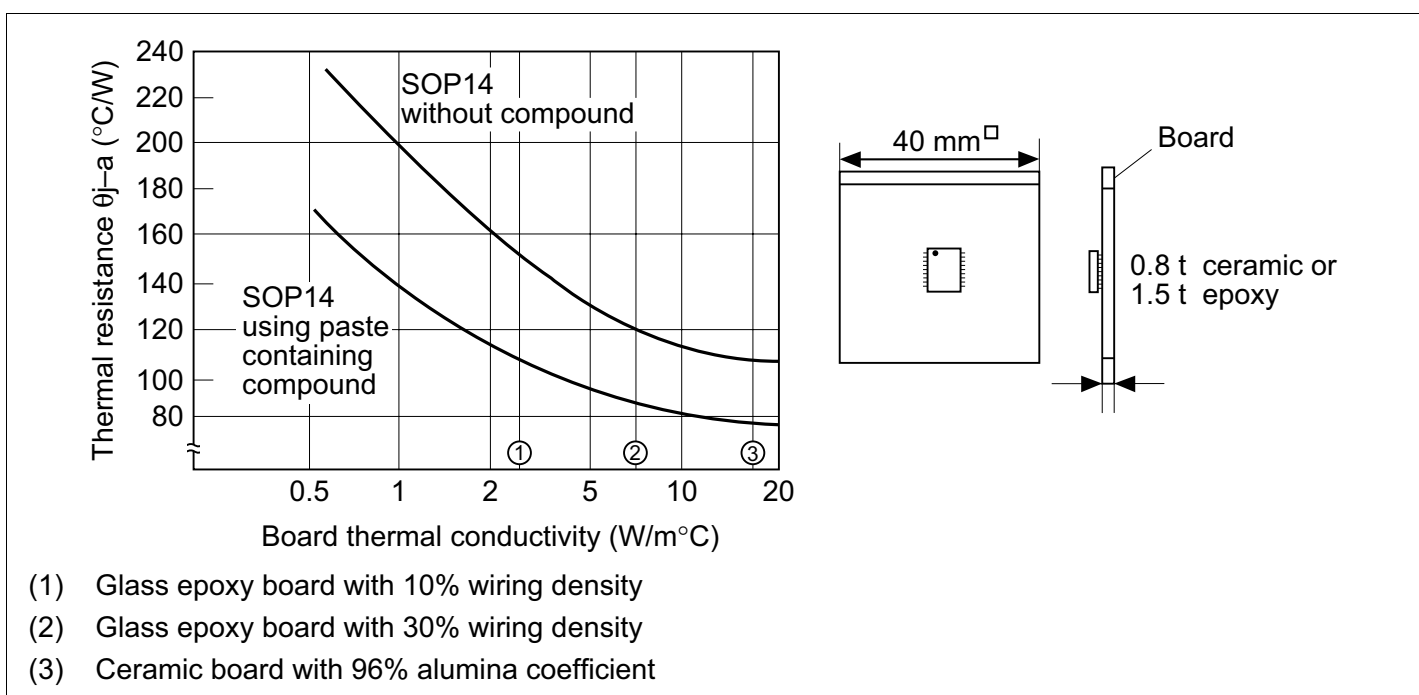
2. Allowable temperature of IC junction part, Tj (max), is as shown below.

$$T_j (\text{max}) = \theta_j - a \cdot P_c (\text{max}) + T_a$$

( $\theta_j - a$  is thermal resistance value during mounting, and  $P_c (\text{max})$  is the maximum value of IC power dissipation.)

Therefore, to keep  $T_j (\text{max}) \leq 125^\circ\text{C}$ , wiring density and board material must be selected according to the board thermal conductivity ratio shown below.

Be careful that the value of  $P_c (\text{max})$  does not exceed that  $P_T$ .

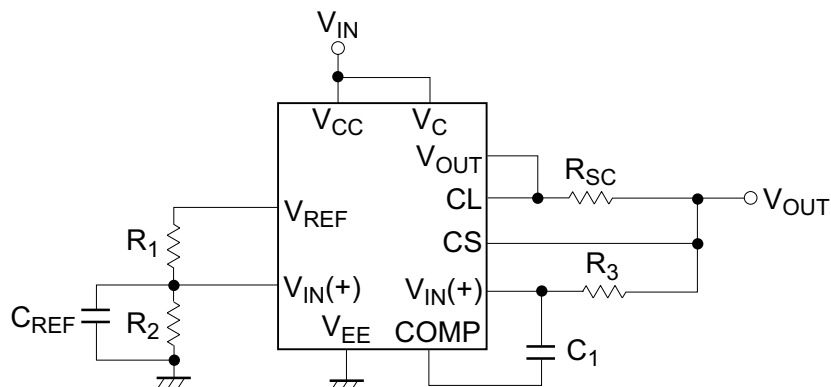


- (1) Glass epoxy board with 10% wiring density
- (2) Glass epoxy board with 30% wiring density
- (3) Ceramic board with 96% alumina coefficient

## Electrical Characteristics (Ta = 25°C)

Item	Symbol	Min	Typ	Max	Unit	Test Conditions
Line regulation	$\delta V_o$ Line	—	0.01	0.1	%	$V_{IN} = 12$ to $15V$
		—	0.1	0.5	%	$V_{IN} = 12$ to $40V$
		—	—	0.4	%	$V_{IN} = 12$ to $15V$ , $T_A = -20$ to $+75^\circ C$
		—	—	0.3	%	$V_{IN} = 12$ to $15V$ , $T_a = 0$ to $+70^\circ C$
Load regulation	$\delta V_o$ Load	—	0.03	0.2	%	$I_{OUT} = 1$ to $50mA$
		—	—	0.7	%	$V_{IN} = 12$ to $15V$ , $T_A = -20$ to $+75^\circ C$
		—	—	0.6	%	$I_{OUT} = 1$ to $50mA$ , $T_a = 0$ to $+70^\circ C$
Ripple rejection	$R_{REJ}$	—	74	—	dB	$f = 50Hz$ to $10kHz$ $C_{REF} = 0$
		—	86	—		$C_{REF} = 5\mu F$
Average temperature coefficient of output voltage	$\delta V_o / \delta T$	—	0.003	0.018	%/°C	$T_A = -20$ to $+75^\circ C$
		—	0.003	0.015	%/°C	$T_a = 0$ to $+70^\circ C$
Reference voltage	$V_{REF}$	6.80	7.15	7.50	V	$V_{IN} = V_{CC} = V_C = 12V$ , $V_{EE} = 0$
Standby current	$I_{ST}$	—	—	4.0	mA	$V_{IN} = 30V$ , $I_L = 0$
Short circuit current limit	$I_{SC}$	—	65	—	mA	$R_{SC} = 10\Omega$ , $V_{OUT} = 0$

## Electrical Characteristics Measuring Circuit



$V_{IN} = V_{CC} = V_C = 12V$ ,  $V_{EE} = 0$ ,  $V_{OUT} = 5.0V$ ,  $I_L = 1mA$ ,  
 $R_{SC} = 0$ ,  $C_1 = 100pF$ ,  $C_{REF} = 0$ ,  $R_2 \approx 5k\Omega$ ,  $R_3 = R_1 R_2 / (R_1 + R_2)$

## HA17723 Applications

### Fixed Voltage Source in Series

**Low Voltage (2 to 7 V) Regulator:** Figure 1 shows the construction of a basic low voltage regulator. The divider (resistors  $R_1$  and  $R_2$ ) from  $V_{REF}$  makes the reference voltage, which will be provided to the noninverted input of the error amplifier, less than output voltage. In the fixed voltage source where the output voltage will be fed back to the error amplifier directly as shown in figure 1. Output voltage will be divided  $V_{REF}$  since the output voltage is equal to the reference voltage.

Thus, the output voltage  $V_{OUT}$  is:

$$V_{OUT} = nV_{REF}, \quad n = \frac{R_2}{R_1 + R_2}$$

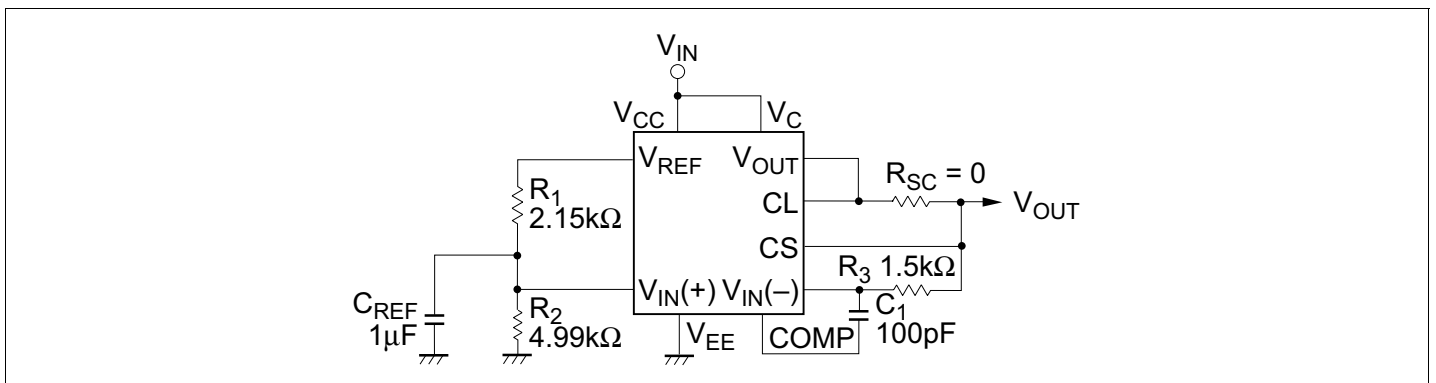


Figure 1 Low Voltage (2 to 7 V) Regulator

**High Voltage (7 to 37 V) Regulator:** Figure 2 shows the construction of a regulator whose output voltage is higher than the reference voltage,  $V_{REF}$ .  $V_{REF}$  is added to the non-inverted input of the error amplifier via a resistor,  $R_3$ . The feedback voltage is produced by dividing the output voltage with resistors  $R_1$  and  $R_2$ .

Thus, the output voltage  $V_{OUT}$  is:

$$V_{OUT} = \frac{V_{REF}}{n}, \quad n = \frac{R_2}{R_1 + R_2}$$

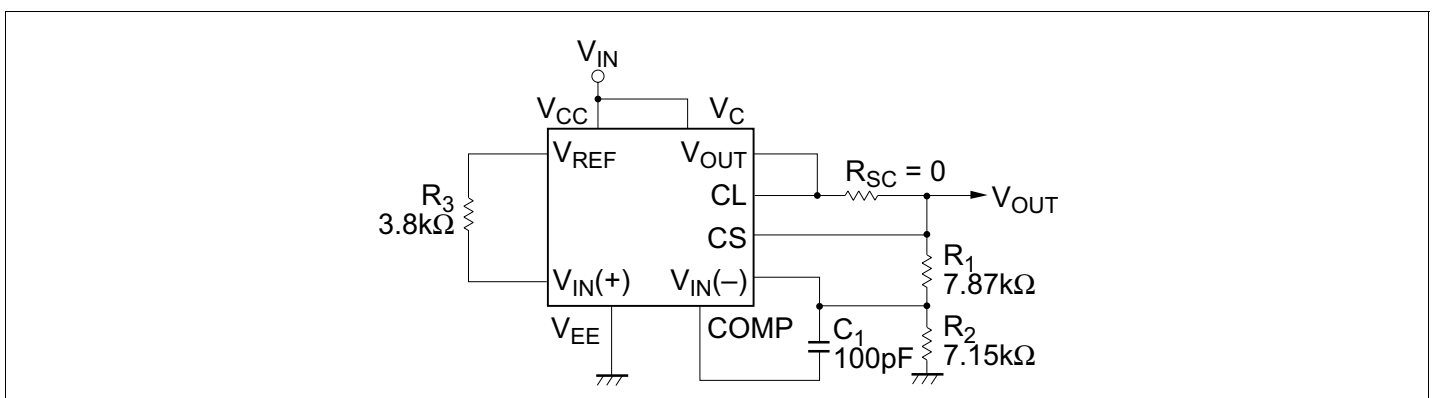


Figure 2 High Voltage (7 to 37 V) Regulator

**Negative Voltage Regulator:** Figure 3 shows the construction of a so-called negative voltage regulator, which generates a negative output voltage with regard to GND. Assume that the output voltage,  $-V_{OUT}$ , increases in the negative direction. As the voltage across the  $R_1$  is larger than that across the  $R_3$ , which provides the reference voltage, the output current of the error amplifier increases. In the control circuit, the impedance decreases with the increase of input current, which makes the base current of the external transistor Q approach GND. As a result, the output voltage returns to the established value and output voltage is stable.

The output voltage  $-V_{OUT}$  of this circuit is:

$$-V_{OUT} = -\left(\frac{R_1 + R_2}{R_3 + R_4} \times \frac{R_3}{R_1}\right) V_{REF}$$

$$= -\frac{(R_1 + R_2) \cdot (R_3 + R_4)}{R_2 \cdot (R_3 + R_4) - R_4 \cdot (R_1 + R_2)} \times \frac{R_3}{R_3 + R_4} V_{REF}$$

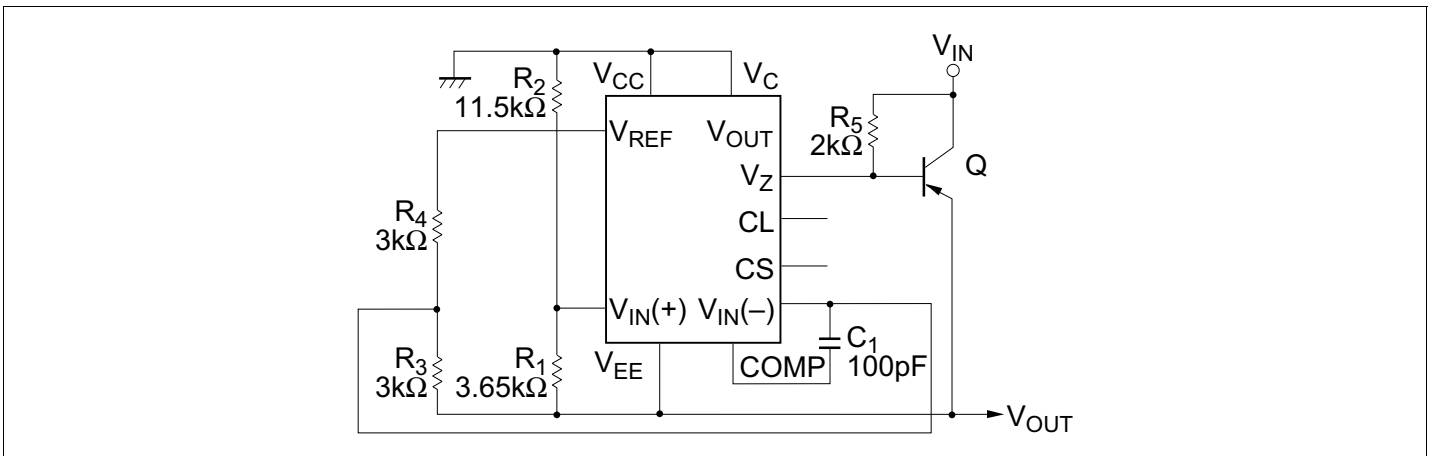


Figure 3 Negative Voltage Regulator

**How to Increase the Output Current:** To increase the output current, you must increase the current capacity of the control circuit. Figures 4 and 5 show examples with external transistors.

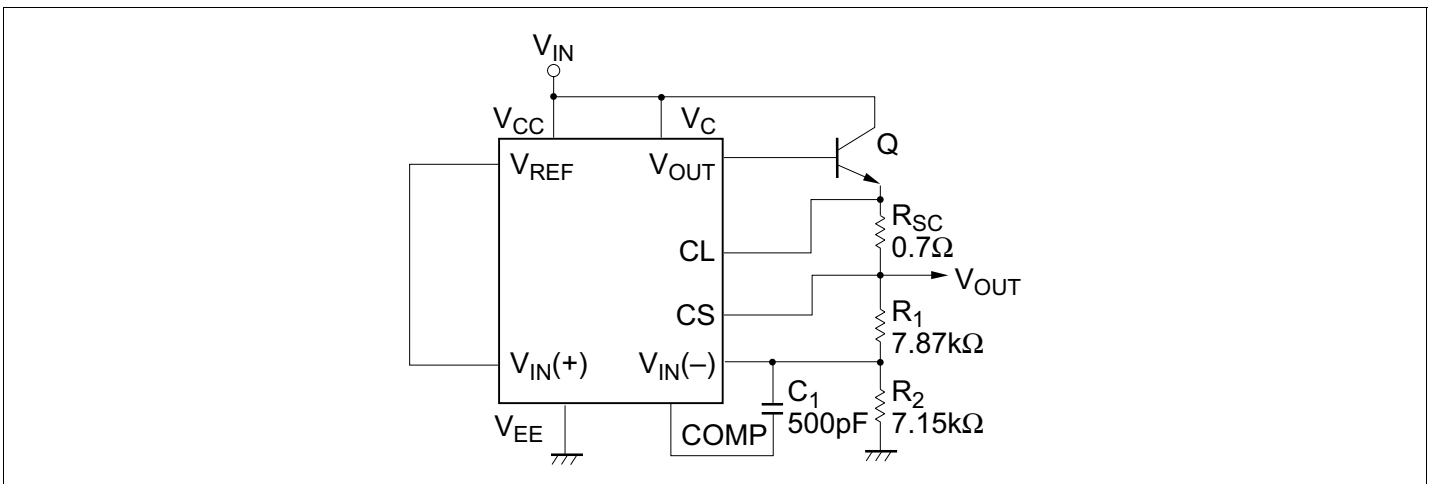


Figure 4 Increasing Output Current (1)

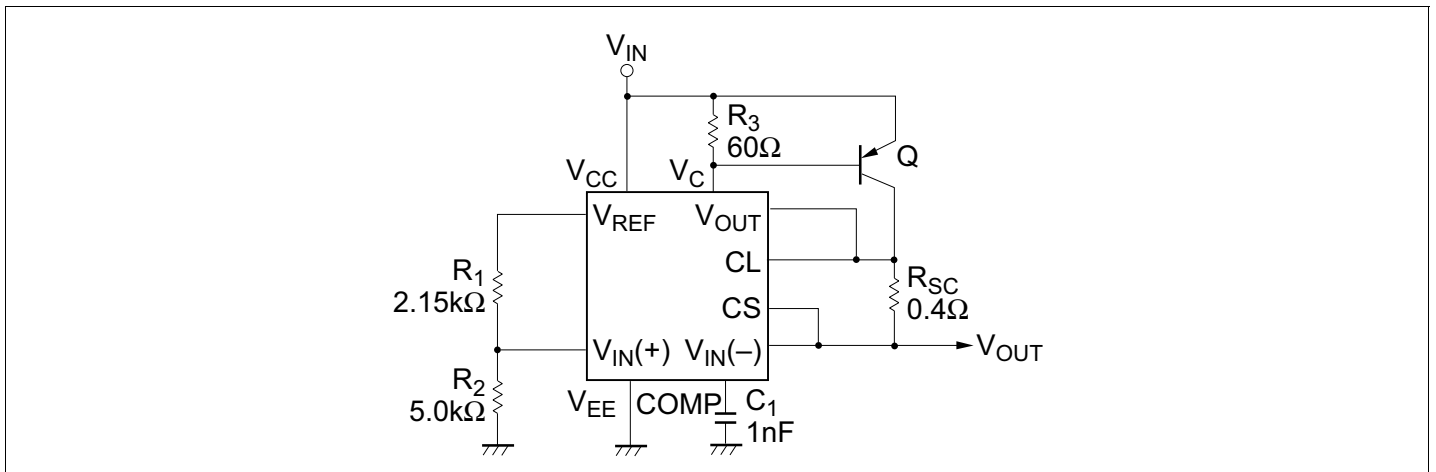


Figure 5 Increasing Output Current (2)

**Fixed Voltage Source in Parallel Control**

Figure 6 shows the circuit of a fixed voltage source in parallel control.

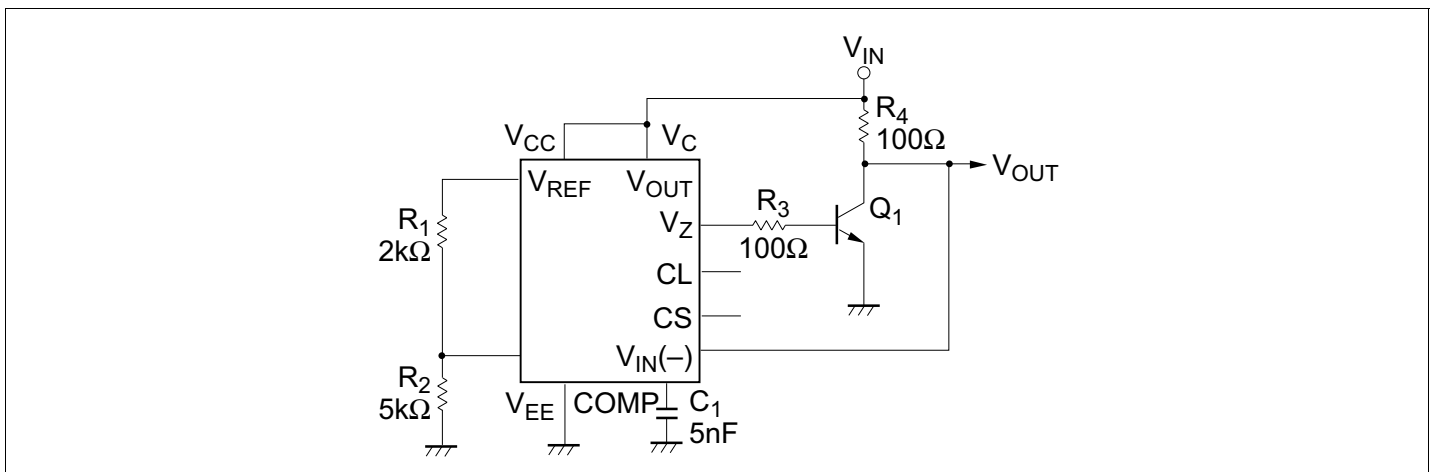


Figure 6 Fixed Voltage Source in Shunt Regulator

**Switching Regulator**

Figure 7 shows a switching regulator circuit. The error amplifier, control circuit, and forward feedback circuit  $R_4$  and  $R_3$  operate in together as a comparator, and make the external transistors  $Q_1$  and  $Q_2$  to turn on/off. In this circuit, the self-oscillation stabilizes the output voltage and the change in output is absorbed by the changes of the switches conducting period.

Figures 8 and 9 show a negative voltage switching regulator circuit and its characteristics.

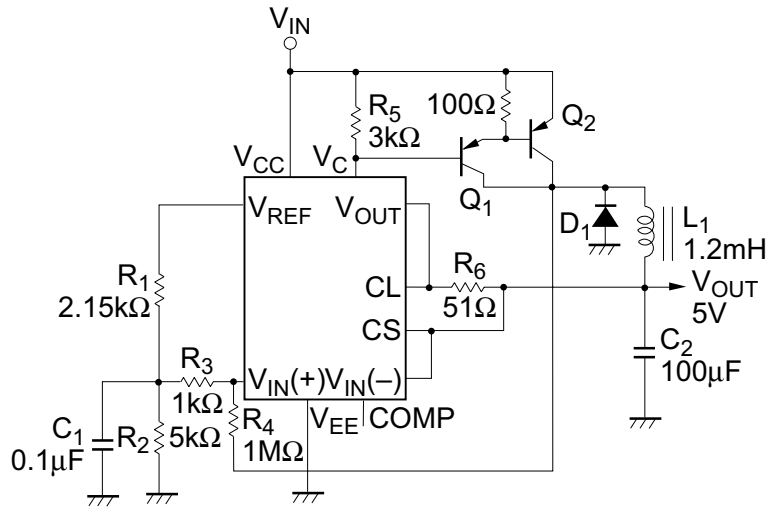


Figure 7 Positive Voltage Switching Regulator

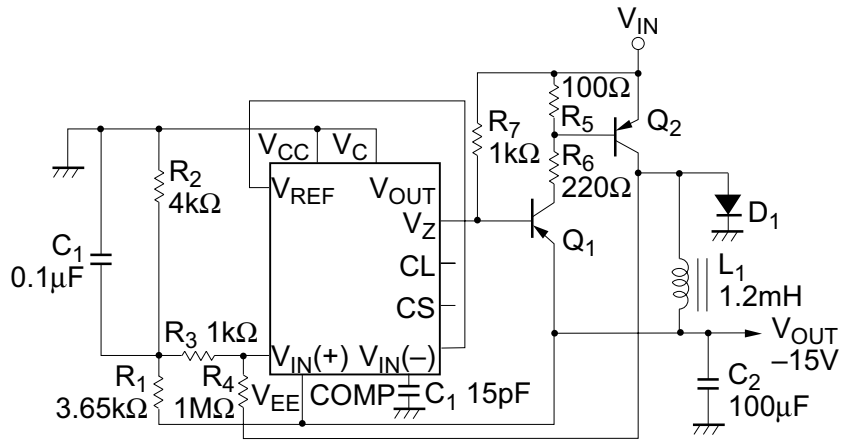


Figure 8 Negative Voltage Switching Regulator

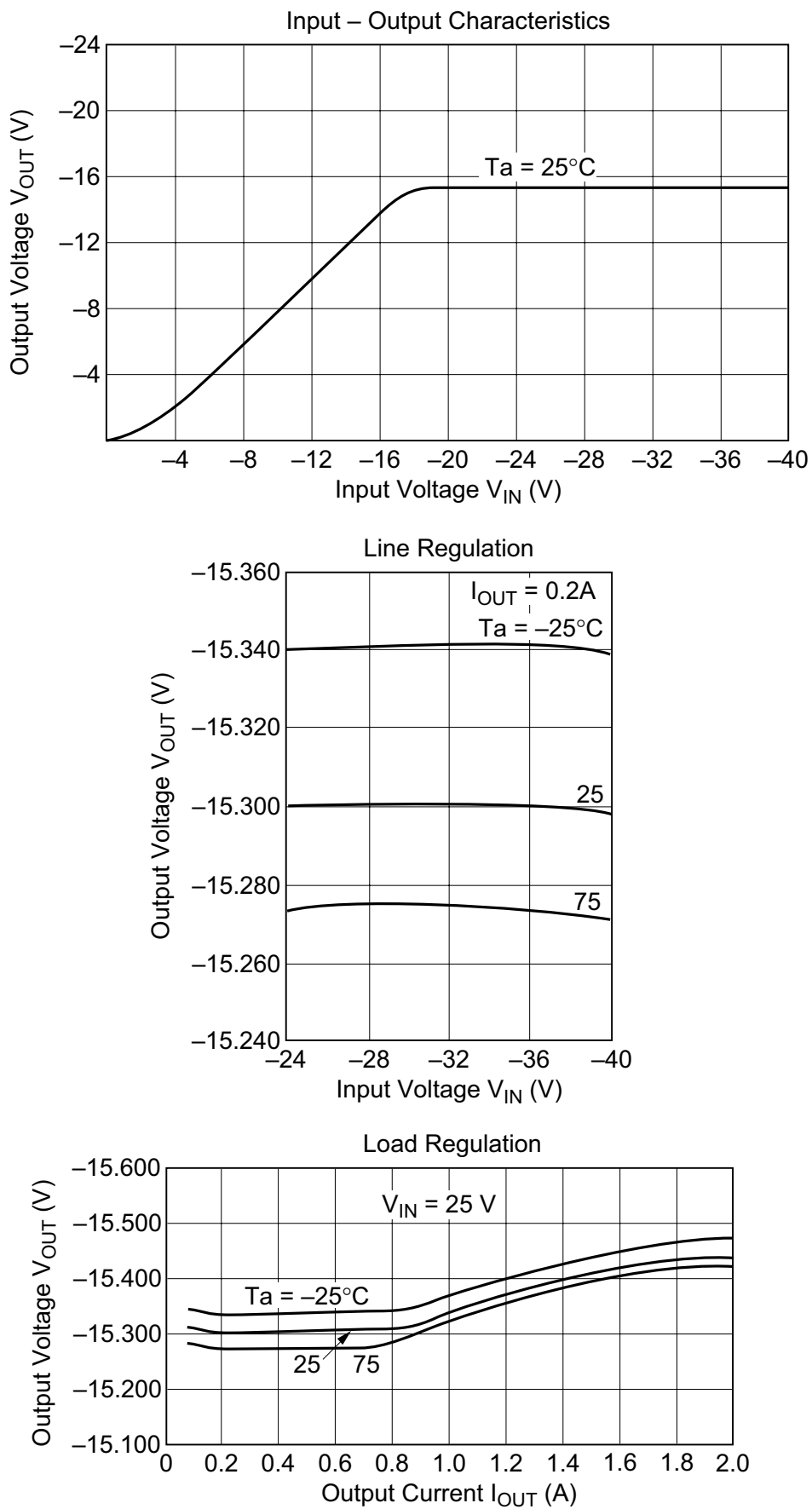


Figure 9 Negative Voltage Switching Regulator Operating Characteristics

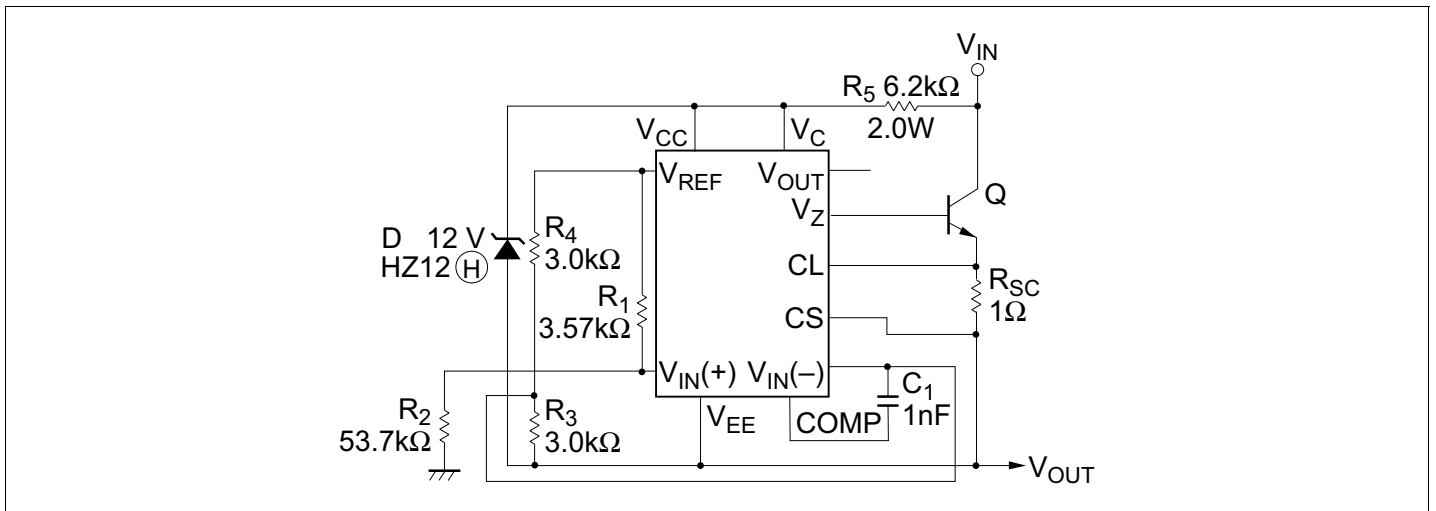
**Floating-Type Fixed Voltage Source**

Voltage sources of the floating type or boost type are typically employed when high voltage output is required. Figure 10 shows the circuit of a floating-type fixed voltage source. Considering the stabilization in this circuit, assume that the output voltage increases. At the input terminal of the error amplifier the non-inverted input will become low compared with the inverted input, and the output current of the error amplifier decreases. Then, the current from the terminal  $V_Z$  in the control circuit decreases. As a result the base current of the external resistor  $Q_1$  will decrease and collector current will decrease, controlling increase of the output voltage.

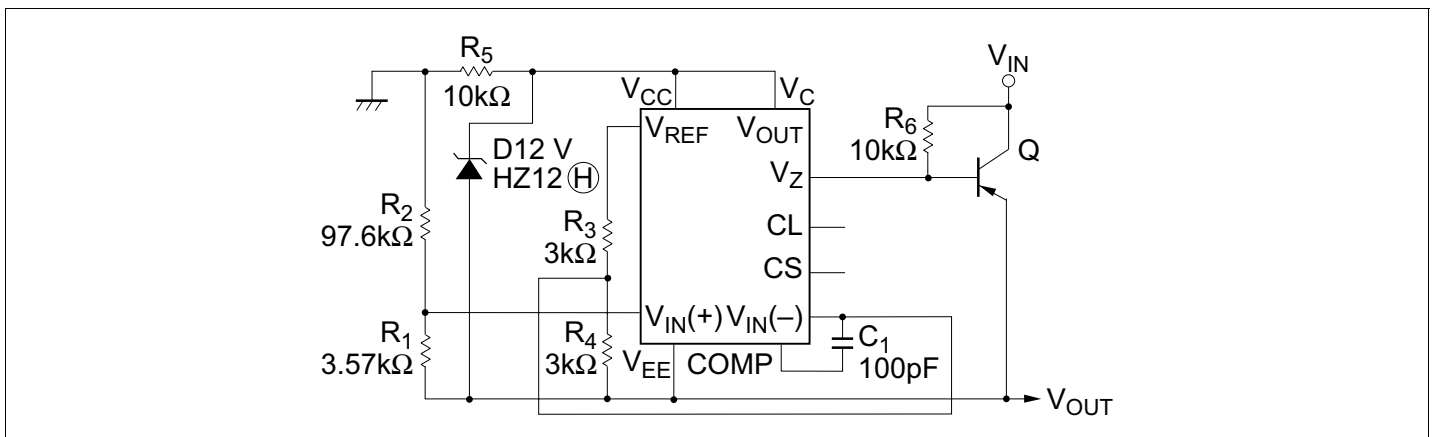
The output voltage  $V_{OUT}$  in the circuit in figure 10

$$V_{OUT} = \left( \frac{R_1 + R_2}{R_3 + R_4} \times \frac{R_4}{R_1} - 1 \right) V_{REF}$$

Figure 11 is the circuit diagram of a negative fixed voltage source in floating type.

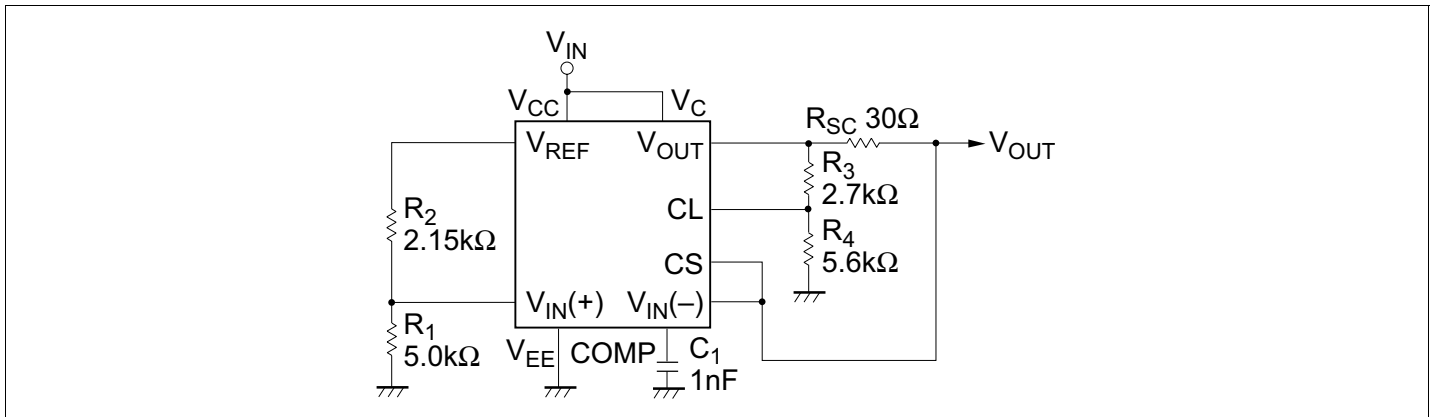


**Figure 10 Positive Voltage Floating Regulator**

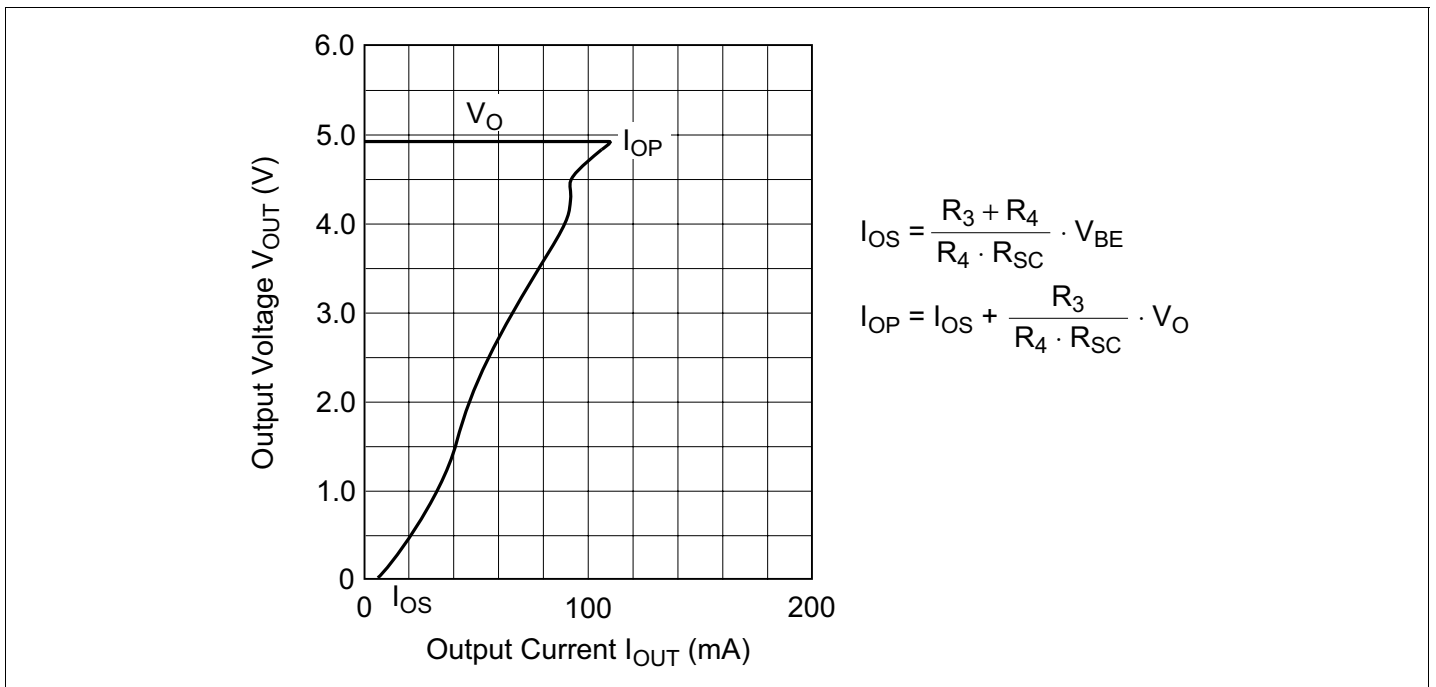


**Figure 11 Negative Voltage Floating Regulator**

**Fixed Voltage Source with Reduction Type Current Limiter**



**Figure 12 Fixed Voltage Source with Reduction Type Current Limiter**



**Figure 13 Current Control Characteristics of Fixed Voltage Source with Reduction Type Current Limiter**

Fixed Voltage Source Switching External Control

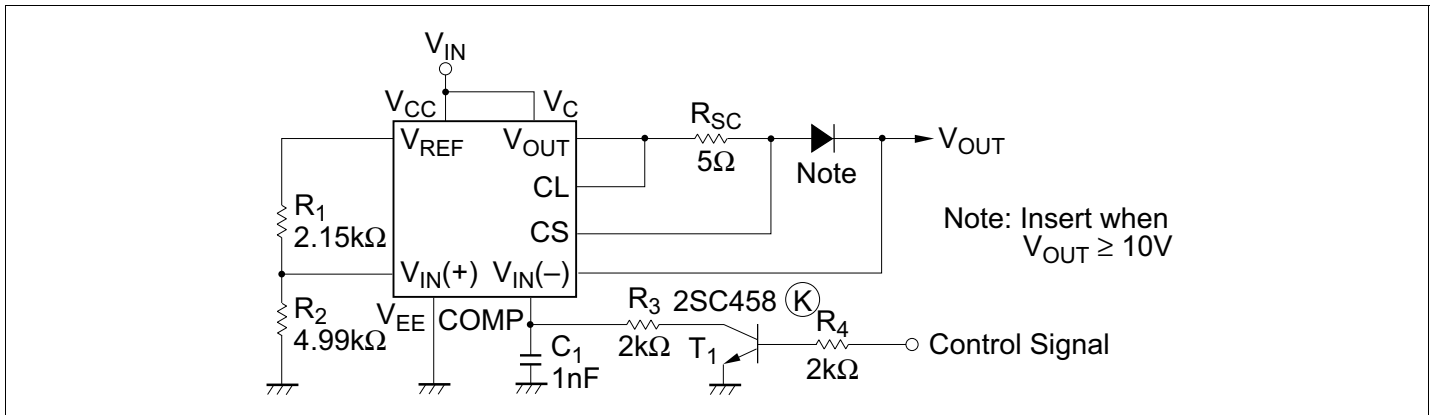


Figure 14 Fixed Voltage Source Switching External Control

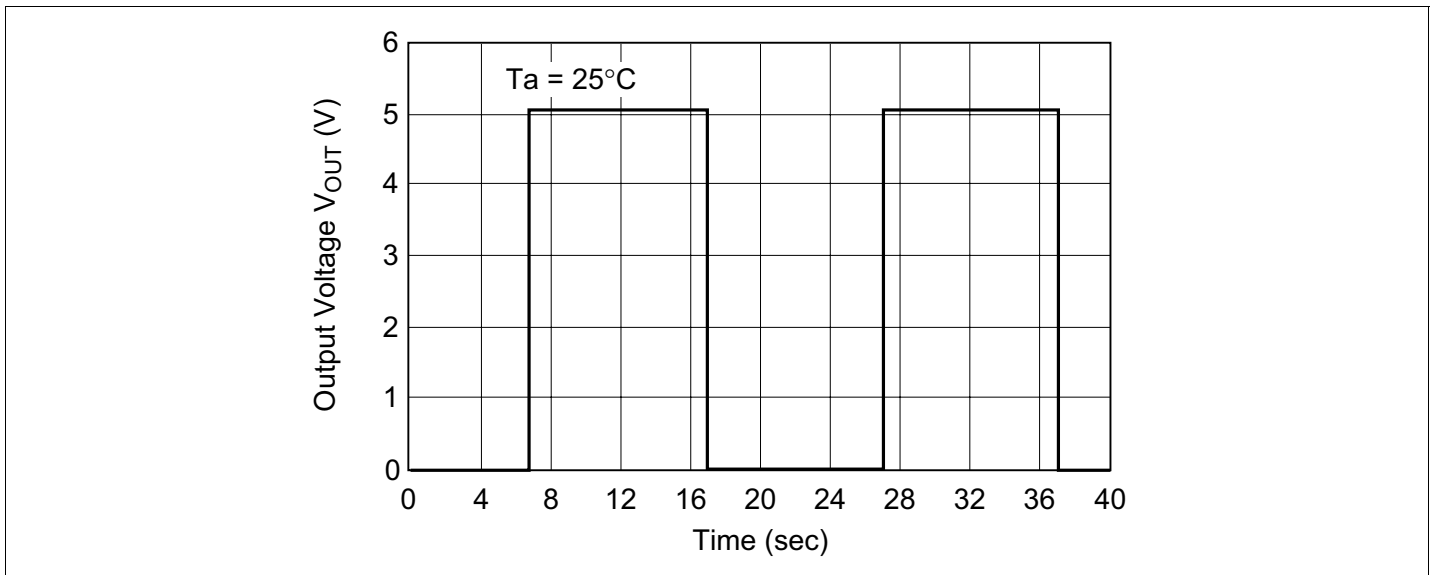
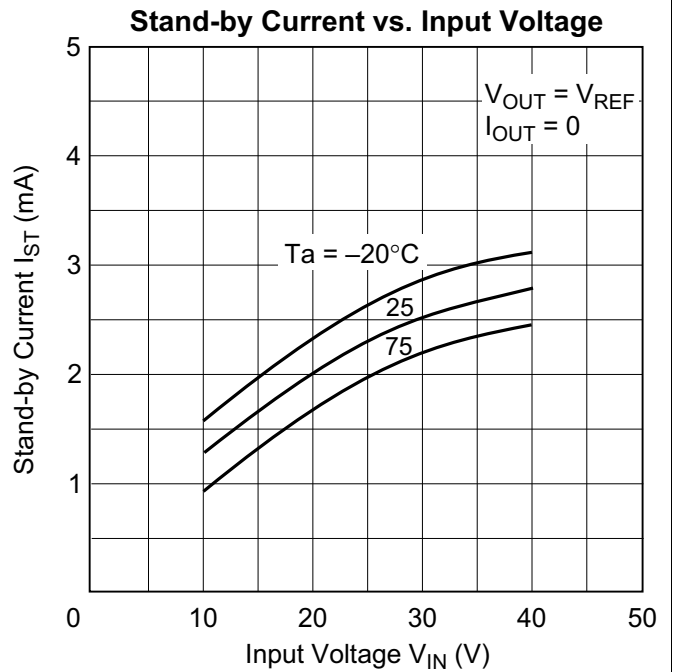
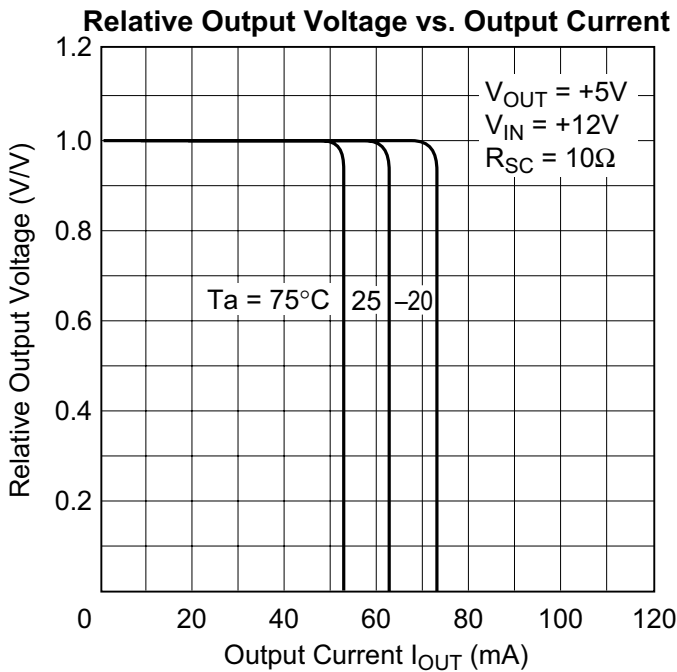
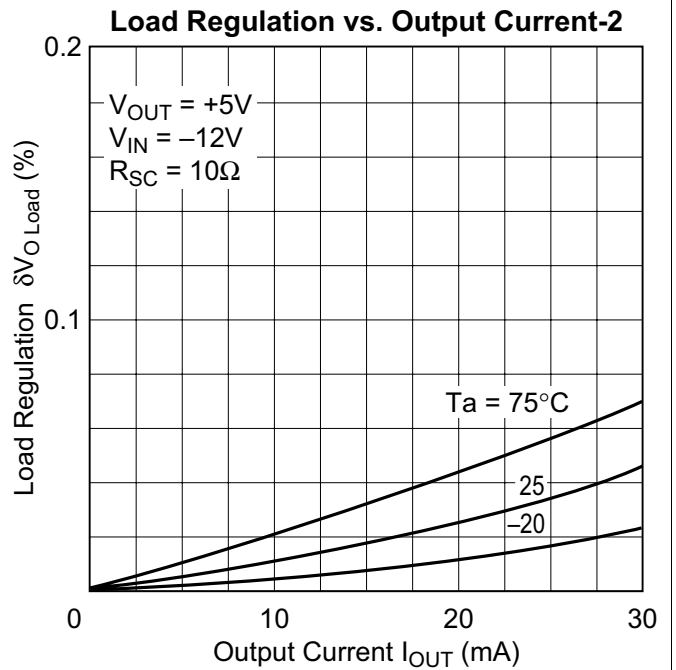
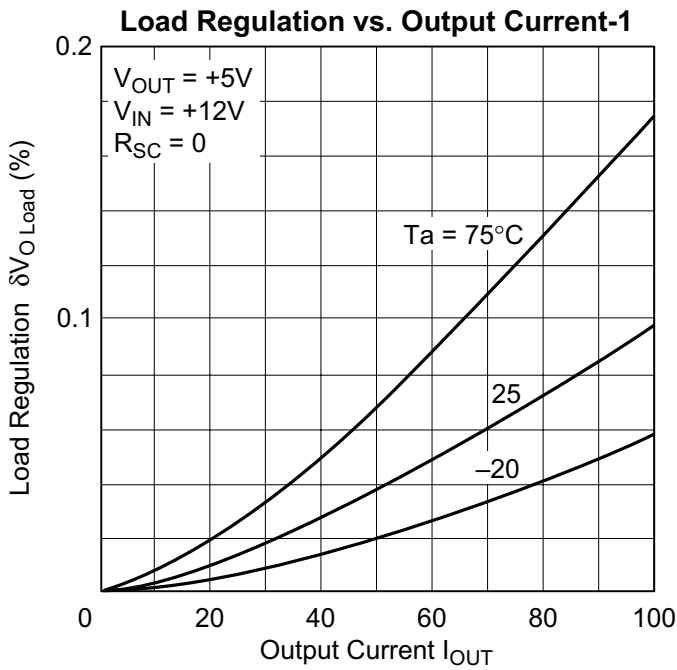
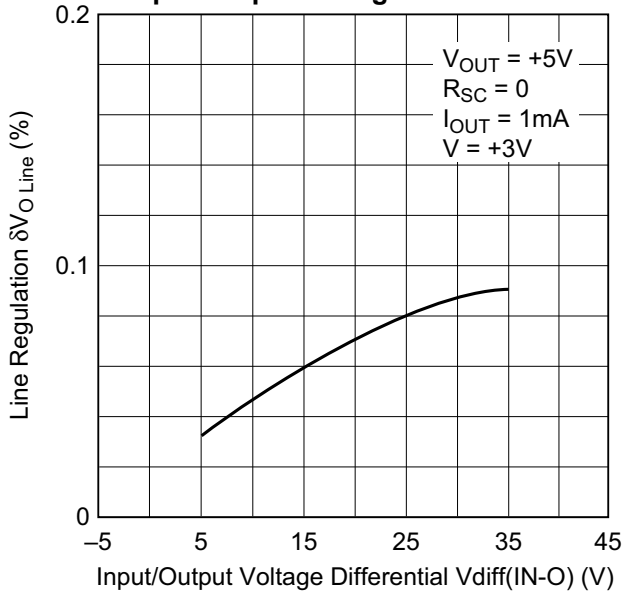


Figure 15 Operating Characteristics of Fixed Voltage Source Switching External Control

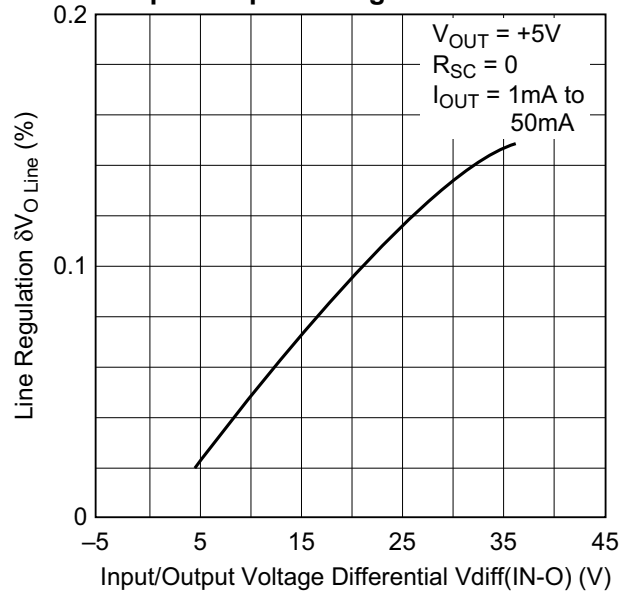
Characteristic Curves



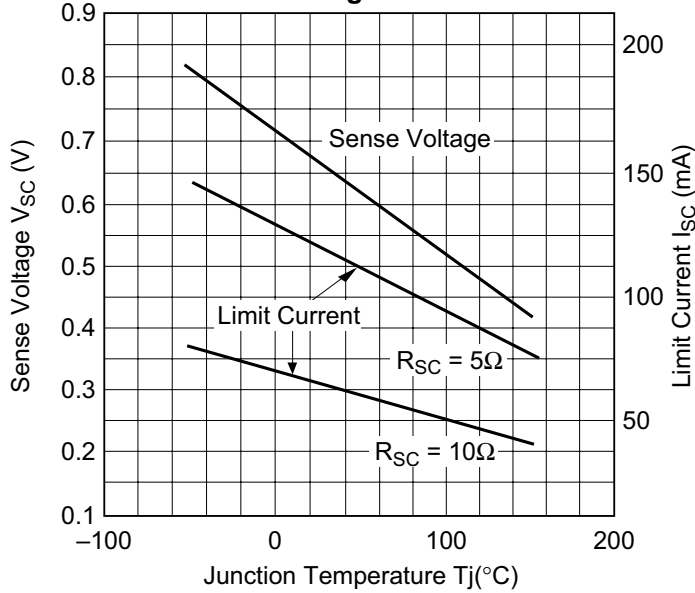
**Line Regulation vs. Input/Output Voltage Differential-1**



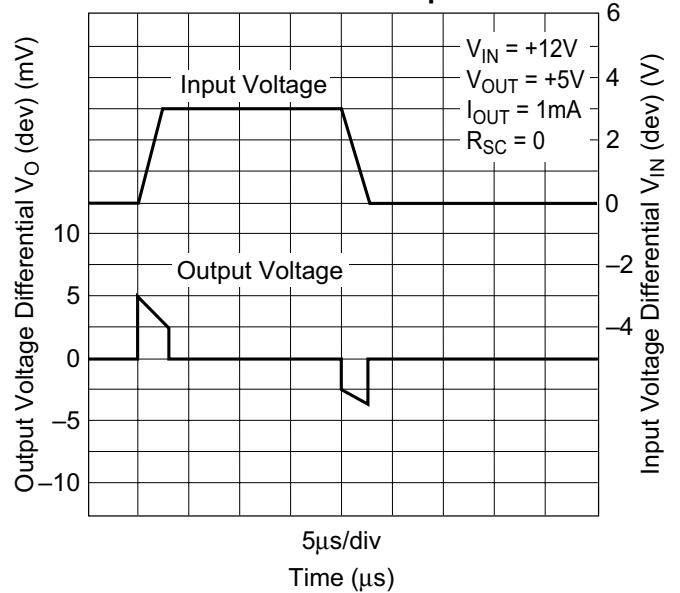
**Line Regulation vs. Input/Output Voltage Differential-2**

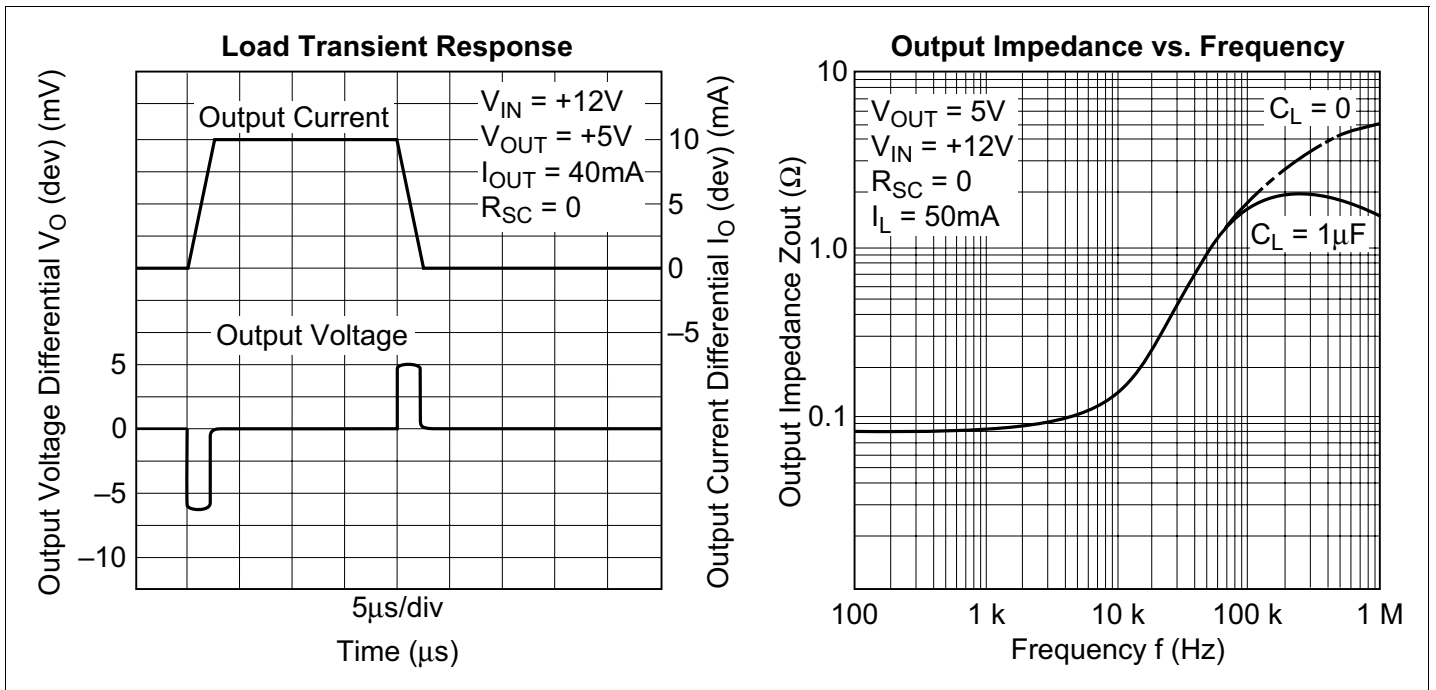


**Current Limiting Characteristics**



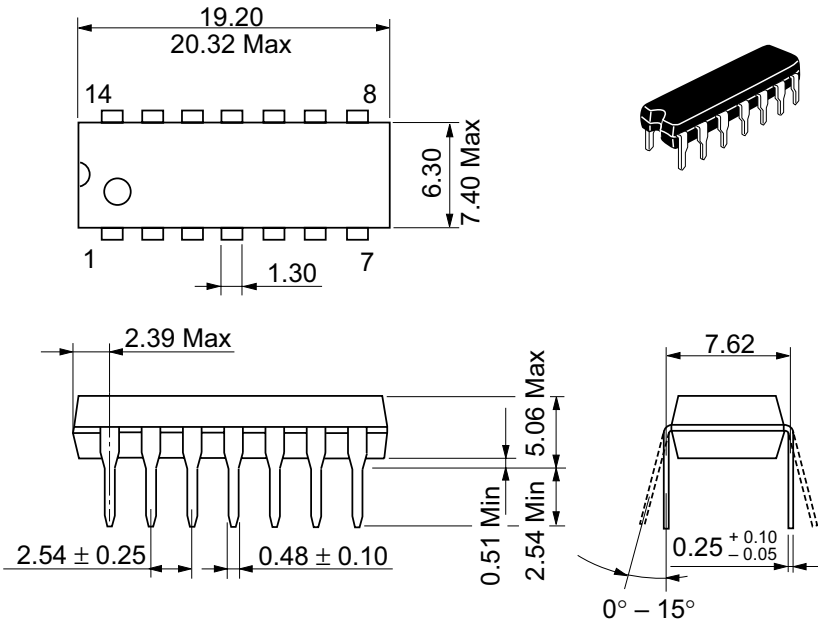
**Line Transient Response**





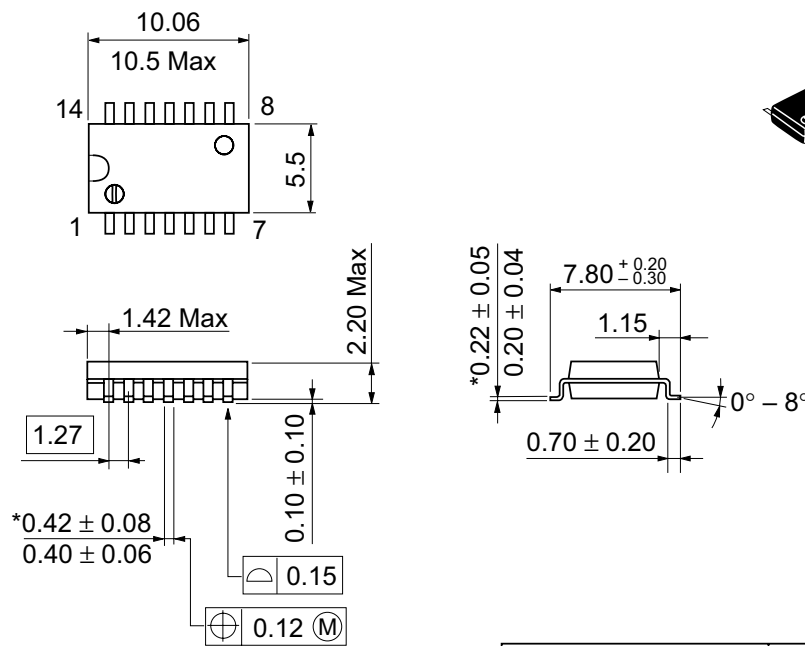
## Package Dimensions

Unit: mm



Hitachi Code	DP-14
JEDEC	Conforms
EIAJ	Conforms
Mass (reference value)	0.97 g

Unit: mm



\*Dimension including the plating thickness  
Base material dimension

Hitachi Code	FP-14DA
JEDEC	—
EIAJ	Conforms
Mass (reference value)	0.23 g

## Cautions

1. Hitachi neither warrants nor grants licenses of any rights of Hitachi's or any third party's patent, copyright, trademark, or other intellectual property rights for information contained in this document. Hitachi bears no responsibility for problems that may arise with third party's rights, including intellectual property rights, in connection with use of the information contained in this document.
2. Products and product specifications may be subject to change without notice. Confirm that you have received the latest product standards or specifications before final design, purchase or use.
3. Hitachi makes every attempt to ensure that its products are of high quality and reliability. However, contact Hitachi's sales office before using the product in an application that demands especially high quality and reliability or where its failure or malfunction may directly threaten human life or cause risk of bodily injury, such as aerospace, aeronautics, nuclear power, combustion control, transportation, traffic, safety equipment or medical equipment for life support.
4. Design your application so that the product is used within the ranges guaranteed by Hitachi particularly for maximum rating, operating supply voltage range, heat radiation characteristics, installation conditions and other characteristics. Hitachi bears no responsibility for failure or damage when used beyond the guaranteed ranges. Even within the guaranteed ranges, consider normally foreseeable failure rates or failure modes in semiconductor devices and employ systemic measures such as fail-safes, so that the equipment incorporating Hitachi product does not cause bodily injury, fire or other consequential damage due to operation of the Hitachi product.
5. This product is not designed to be radiation resistant.
6. No one is permitted to reproduce or duplicate, in any form, the whole or part of this document without written approval from Hitachi.
7. Contact Hitachi's sales office for any questions regarding this document or Hitachi semiconductor products.

# HITACHI

## Hitachi, Ltd.

Semiconductor & Integrated Circuits.

Nippon Bldg., 2-6-2, Ohte-machi, Chiyoda-ku, Tokyo 100-0004, Japan

Tel: Tokyo (03) 3270-2111 Fax: (03) 3270-5109

URL	NorthAmerica	: <a href="http://semiconductor.hitachi.com/">http://semiconductor.hitachi.com/</a>
	Europe	: <a href="http://www.hitachi-eu.com/hel/ecg">http://www.hitachi-eu.com/hel/ecg</a>
	Asia (Singapore)	: <a href="http://www.has.hitachi.com.sg/grp3/sicd/index.htm">http://www.has.hitachi.com.sg/grp3/sicd/index.htm</a>
	Asia (Taiwan)	: <a href="http://www.hitachi.com.tw/E/Product/SICD_Frame.htm">http://www.hitachi.com.tw/E/Product/SICD_Frame.htm</a>
	Asia (HongKong)	: <a href="http://www.hitachi.com.hk/eng/bo/grp3/index.htm">http://www.hitachi.com.hk/eng/bo/grp3/index.htm</a>
	Japan	: <a href="http://www.hitachi.co.jp/Sicd/indx.htm">http://www.hitachi.co.jp/Sicd/indx.htm</a>

### For further information write to:

Hitachi Semiconductor  
(America) Inc.  
179 East Tasman Drive,  
San Jose, CA 95134  
Tel: <1> (408) 433-1990  
Fax: <1> (408) 433-0223

Hitachi Europe GmbH  
Electronic components Group  
Dornacher Straße 3  
D-85622 Feldkirchen, Munich  
Germany  
Tel: <49> (89) 9 9180-0  
Fax: <49> (89) 9 29 30 00  
Hitachi Europe Ltd.  
Electronic Components Group.  
Whitebrook Park  
Lower Cookham Road  
Maidenhead  
Berkshire SL6 8YA, United Kingdom  
Tel: <44> (1628) 585000  
Fax: <44> (1628) 778322

Hitachi Asia Pte. Ltd.  
16 Collyer Quay #20-00  
Hitachi Tower  
Singapore 049318  
Tel: 535-2100  
Fax: 535-1533  
Hitachi Asia Ltd.  
Taipei Branch Office  
3F, Hung Kuo Building. No.167,  
Tun-Hwa North Road, Taipei (105)  
Tel: <886> (2) 2718-3666  
Fax: <886> (2) 2718-8180

Hitachi Asia (Hong Kong) Ltd.  
Group III (Electronic Components)  
7/F., North Tower, World Finance Centre,  
Harbour City, Canton Road, Tsim Sha Tsui,  
Kowloon, Hong Kong  
Tel: <852> (2) 735 9218  
Fax: <852> (2) 730 0281  
Telex: 40815 HITEC HX

Copyright © Hitachi, Ltd., 1998. All rights reserved. Printed in Japan.

## HITACHI