

Silicon NPN Power Transistors

2SC1953

DESCRIPTION

- With TO-126 package
- Complement to type 2SA914
- High V_{CE0}

APPLICATIONS

- For low-frequency power pre-amplification

PINNING

PIN	DESCRIPTION
1	Emitter
2	Collector;connected to mounting base
3	Base

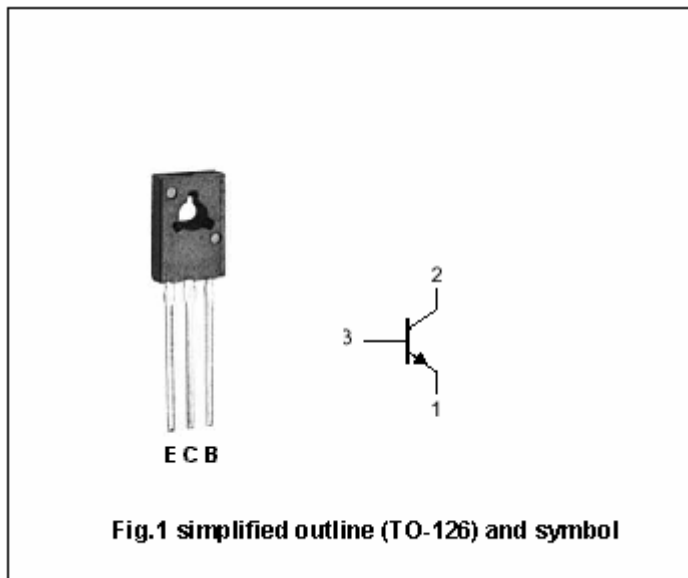

Absolute Maximun Ratings ($T_a=25$)

SYMBOL	PARAMETER	CONDITIONS	VALUE	UNIT
V_{CBO}	Collector-base voltage	Open emitter	150	V
V_{CEO}	Collector-emitter voltage	Open base	150	V
V_{EBO}	Emitter-base voltage	Open collector	5	V
I_C	Collector current		50	mA
I_{CM}	Collector current-peak		100	mA
P_C	Collector power dissipation		1.2	W
T_j	Junction temperature		150	
T_{stg}	Storage temperature		-55~150	

Silicon NPN Power Transistors

2SC1953

CHARACTERISTICS

T_j=25 unless otherwise specified

SYMBOL	PARAMETER	CONDITIONS	MIN	TYP.	MAX	UNIT
V _{(BR)CEO}	Collector-emitter breakdown voltage	I _C =0.1mA; I _B =0	150			V
V _{(BR)EBO}	Emitter-base breakdown voltage	I _E =10 μ A ; I _C =0	5			V
V _{CEsat}	Collector-emitter saturation voltage	I _C =30mA ; I _B =3mA			1	V
I _{CBO}	Collector cut-off current	V _{CB} =100V; I _E =0			1	μ A
h _{FE}	DC current gain	I _C =10mA ; V _{CE} =5V	90		450	
C _{OB}	Output capacitance	I _E =0 ; V _{CB} =10V; f=1MHz			3	pF
f _T	Transition frequency	I _E =-10mA ; V _{CB} =10V	70			MHz

◆ h_{FE} Classifications

Q	R	S	T
90-155	130-220	185-330	260-450

Silicon NPN Power Transistors

2SC1953

PACKAGE OUTLINE

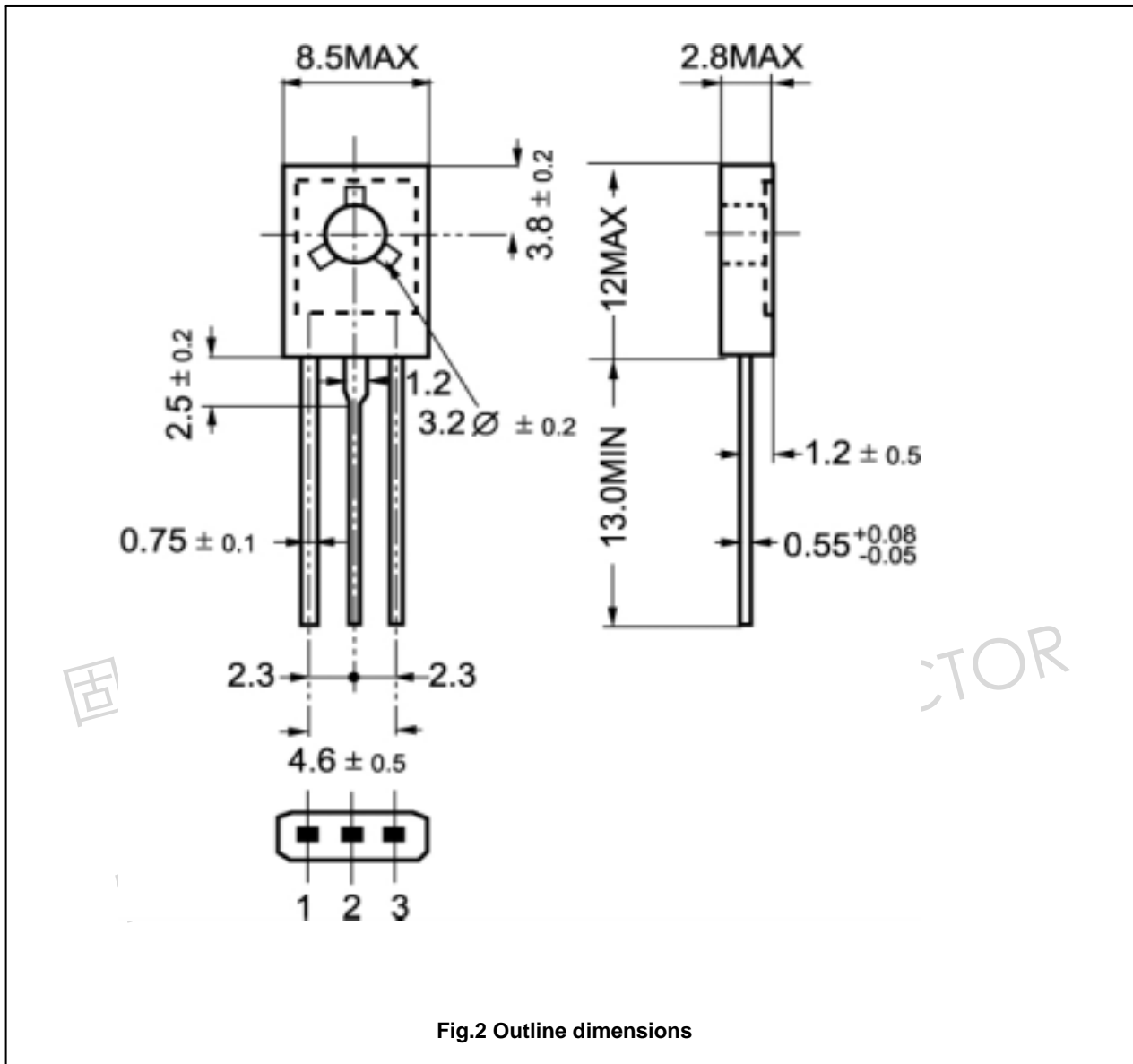

Silicon NPN Power Transistors

2SC1953

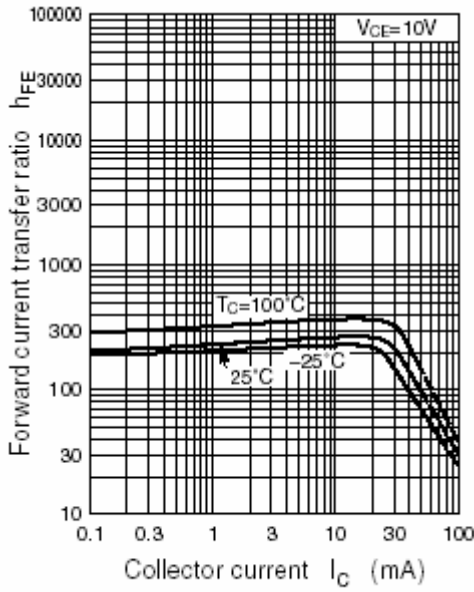

Fig.3 DC current Gain

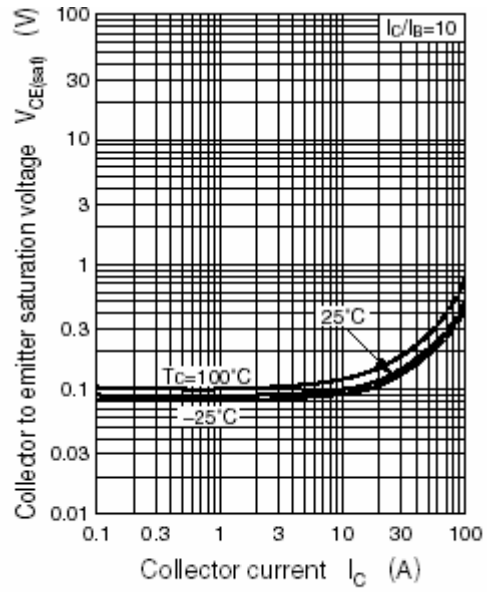

Fig.4 Collector-Emitter Saturation Voltage

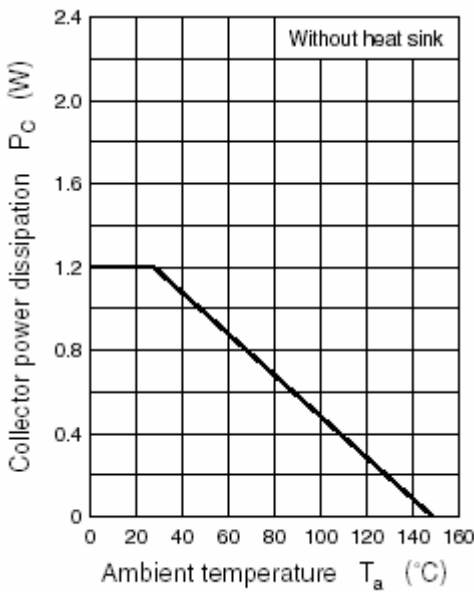

Fig.5 Power Derating