

isc Silicon NPN Power Transistor

BU2508AW

DESCRIPTION

- Collector-Emitter Sustaining Voltage-
: $V_{CEO(SUS)} = 700V$ (Min)
- High Switching Speed

APPLICATIONS

- Designed for use in horizontal deflection circuits of color TV receivers.

ABSOLUTE MAXIMUM RATINGS($T_a=25^\circ C$)

SYMBOL	PARAMETER	VALUE	UNIT
V_{CES}	Collector- Emitter Voltage($V_{BE} = 0$)	1500	V
V_{CEO}	Collector-Emitter Voltage	700	V
V_{EBO}	Emitter-Base Voltage	7.5	V
I_C	Collector Current- Continuous	8	A
I_{CM}	Collector Current-Peak	15	A
I_B	Base Current- Continuous	4	A
I_{BM}	Base Current-Peak	6	A
P_C	Collector Power Dissipation @ $T_C=25^\circ C$	125	W
T_J	Junction Temperature	150	$^\circ C$
T_{stg}	Storage Temperature Range	-55~150	$^\circ C$

THERMAL CHARACTERISTICS

SYMBOL	PARAMETER	MAX	UNIT
$R_{th\ j-c}$	Thermal Resistance, Junction to Case	1.0	$^\circ C/W$

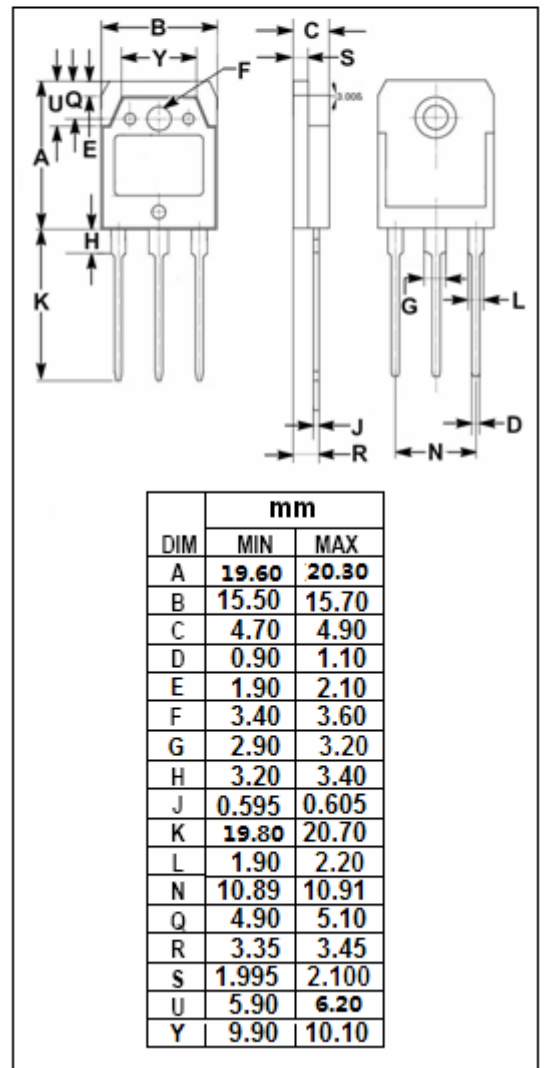
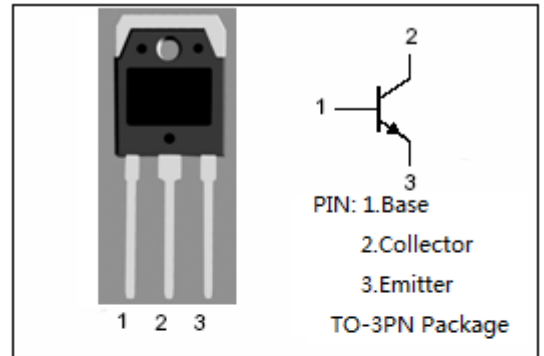

isc Silicon NPN Power Transistor**BU2508AW****ELECTRICAL CHARACTERISTICS** $T_C=25^{\circ}\text{C}$ unless otherwise specified

SYMBOL	PARAMETER	CONDITIONS	MIN	TYP.	MAX	UNIT
$V_{CEO(SUS)}$	Collector-Emitter Sustaining Voltage	$I_C= 30\text{mA}; I_B= 0$	700			V
$V_{(BR)EBO}$	Emitter-Base Breakdown Voltage	$I_E= 1\text{mA}; I_C= 0$	7.5			V
$V_{CE(sat)}$	Collector-Emitter Saturation Voltage	$I_C= 4.5\text{A}; I_B= 1.12\text{A}$			1.0	V
$V_{BE(sat)}$	Base-Emitter Saturation Voltage	$I_C= 4.5\text{A}; I_B= 1.7\text{A}$			1.1	V
I_{CES}	Collector Cutoff Current	$V_{CE}= 1500\text{V}; V_{BE}= 0$ $V_{CE}= 1500\text{V}; V_{BE}= 0; T_C=125^{\circ}\text{C}$			1.0 2.0	mA
I_{EBO}	Emitter Cutoff Current	$V_{EB}= 7.5\text{V}; I_C= 0$			1.0	mA
h_{FE-1}	DC Current Gain	$I_C= 0.1\text{A}; V_{CE}= 5\text{V}$		13		
h_{FE-2}	DC Current Gain	$I_C= 4.5\text{A}; V_{CE}= 1\text{V}$	4		7	
C_{OB}	Output Capacitance	$I_E= 0; V_{CB}= 10\text{V}; f_{test}= 1\text{MHz}$		80		pF