

HA1124 HA1125

TV SOUND SYSTEM

FUNCTIONS

- IF Amplifier-Limiter
- FM Detector
- Electronic Attenuator
- Audio Driver

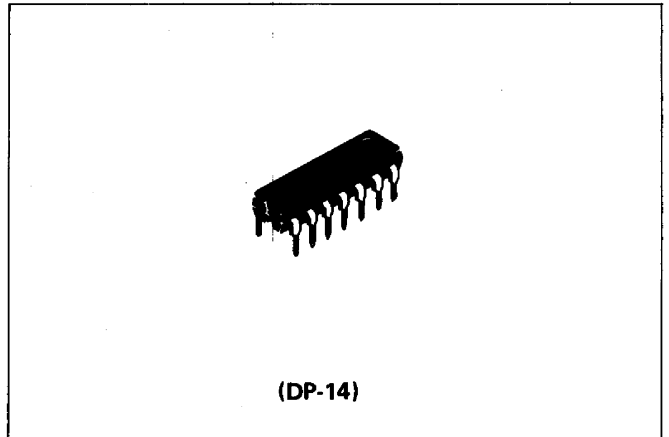

CIRCUIT SCHEMATIC

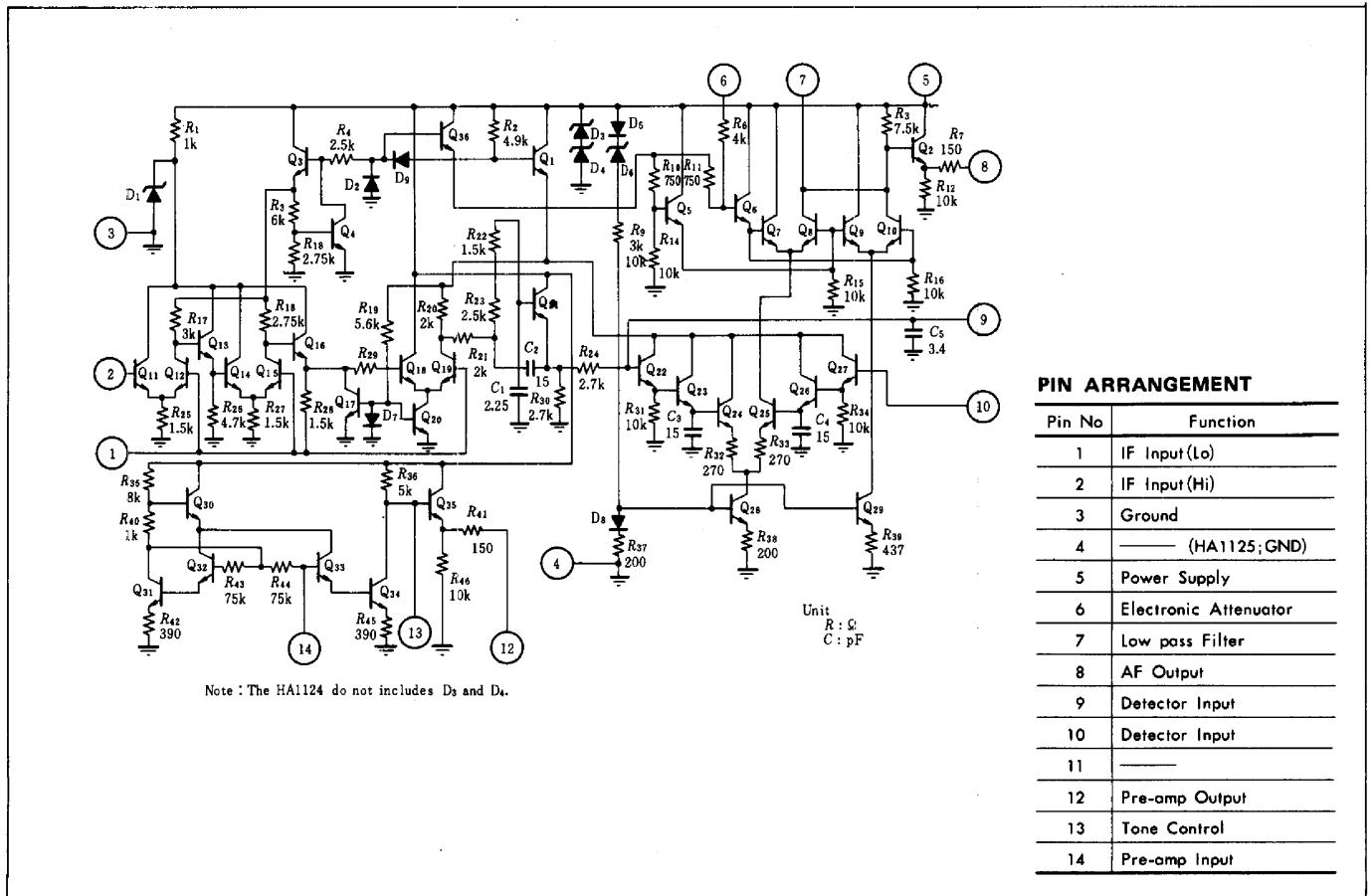

PIN ARRANGEMENT

Pin No	Function
1	IF Input (Lo)
2	IF Input (Hi)
3	Ground
4	(HA1125; GND)
5	Power Supply
6	Electronic Attenuator
7	Low pass Filter
8	AF Output
9	Detector Input
10	Detector Input
11	
12	Pre-amp Output
13	Tone Control
14	Pre-amp Input

ABSOLUTE MAXIMUM RATINGS(1) (T_a = 25°C)

Item	Symbol	HA1124	HA1125	Unit
Input Voltage	V _{in}	±3	±3	V
Supply Current	I _{cc}	50	50	mA
Power Dissipation	P _r *	350	400	mW
Operating Temperature	T _{opr}	-20 to +85	-20 to +85	°C
Storage Temperature	T _{stg}	-55 to +125	-55 to +125	°C

* Value at T_a = 85°C

HA1124, HA1125

■ ABSOLUTE MAXIMUM RATINGS(2)

The following chart gives the range of voltages which can be applied to the terminals listed vertically with respect to the terminals listed horizontally. For example, the voltage range of the vertical terminal 9 with respect to terminal 3 is 0 to +4 volts.

	4	5	6	7	8	9	10	11	12	13	14	1	2	3	
4															
5			+13 0	+13 0	+13 0	*	*	INTERNAL CONNECTION DO NOT USE	+13 0	+13 0	*	*	*	**	
6				*	*	*	*		*	*	*	*	*	*	+13 -5
7					+1 -4	*	*		*	*	*	*	*	*	+13 0
8						*	*		*	*	*	*	*	*	*
9							*		*	*	*	*	*	*	+4 0
10									*	*	*	*	*	*	+4 -5
11								INTERNAL CONNECTION DO NOT USE							
12									+4 -1	*	*	*	*	*	
13										*	*	*	*	*	
14											*	*	*	+3 -5	
1													+5 -5	+5 -5	
2														+4 -5	
3															

Notes: * Voltages are not normally applied between these terminals.

**Terminal 5 may be connected to any positive voltage through a suitable resistor provided that the current and dissipation ratings are not exceeded.

Terminal No.	I_{IN} (mA)	I_{OUT} (mA)
4		
5	50	1
6	1	1
7	1	1
8	0.5	6
9	1	1
10	1	0.1
11	DO NOT USE	
12	0.5	6
13	1	2
14	1	0.1
1	1	0.1
2	1	0.1
3	0.1	50

■ ELECTRICAL CHARACTERISTICS (This table is applied to the HA1125 only)

Item	Symbol	Test Conditions	min	typ	max	Unit
Zener Regulating Voltage	V_s		10.3	11.2	12.2	V
Current into Terminal 5	I_5	Connect Terminal 5 to +9V	10	16	24	mA
Total Device Dissipation	P_T		339	351	362	mW
Terminal 1 Voltage	V_1		—	2	—	V
Terminal 7 Voltage	V_7		—	6.1	—	V
Terminal 9 Voltage	V_9		—	3.7	—	V
Terminal 12 Voltage	V_{12}		4.0	5.1	5.8	V
Input Limiting Voltage	$V_{i(lim)}$	$f_o = 4.5\text{MHz}$, $f_m = 400\text{Hz}$, $\Delta f = 25\text{kHz}$	—	200	400	μV
AM Rejection	AMR	$V_{in} = 2, 10, 100\text{mVrms}$, $f = 4.5\text{MHz}$, AM: 30% mod. (FM: 100% mod.)	40	50	—	dB
Forward Transadmittance	$ y_m $	$f = 4.5\text{MHz}$, Input Terminal 2 to 1	—	500	—	mS
Phase Angle	θ	Output Terminal 9 to 3	—	46	—	deg
Feedback Capacitance	C_{fb}	$f = 1\text{MHz}$, Terminal 2 to 9	—	—	0.02	pF
Input Resistance	R_{in}	$f = 4.5\text{MHz}$, Terminal 2 to 1	—	17	—	k Ω
Input Capacitance	C_{in}		—	4	—	pF
Output Resistance	R_{out}	$f = 4.5\text{MHz}$, Terminal 9 to 3	—	3.25	—	k Ω
Output Capacitance	C_{out}		—	75	—	pF
Recovered AF Voltage	$V_{O(AF)}$	$V_{in} = 100\text{mV}$, $f = 4.5\text{MHz}$,	0.5	0.75	—	Vrms
Total Harmonic Distortion	T.H.D	$f_m = 400\text{Hz}$, $\Delta f = 25\text{kHz}$	—	0.9	2	%
Output Resistance Terminal 7	R_{out7}		—	7.5	—	k Ω
Output Resistance Terminal 8	R_{out8}		—	300	—	Ω
Max. Attenuation		Terminal 6 Open	60	80	—	dB
Play-through Voltage		Terminal 6 Open	—	0.075	1	mV
Voltage Gain	$G_{V(AF)}$	$V_{in} = 0.1\text{Vrms}$, $f = 400\text{Hz}$	17.5	20	—	dB
Total Harmonic Distortion (AF)	T.H.D (AF)	$V_{out} = 2\text{Vrms}$, $f = 400\text{Hz}$	—	1.5	—	%
Undistorted Output Voltage	V_{out}	T.H.D = 5%, $f = 400\text{Hz}$	2.0	2.5	—	V
Input Resistance	$R_{in(AF)}$	$f = 400\text{Hz}$, Terminal 14 to 3	—	70	—	k Ω
Output Resistance	$R_{out(AF)}$	$f = 400\text{Hz}$, Terminal 12 to 3	—	270	—	Ω

Note) TEST CONDITIONS: $T_a = 25^\circ\text{C}$, $V_{cc} = 30\text{V}$ applied to Terminal 5 through $R_c = 600\Omega$ and DC Volume Control = 0 unless otherwise specified.

■ TEST CIRCUIT (This test circuit is applied to the HA1125 only)

