

BIPOLAR ANALOG INTEGRATED CIRCUIT

μ PC1373H

REMOTE CONTROL PREAMPLIFIER

DESCRIPTION

The μ PC1373H is a silicon monolithic integrated circuit designed for a remote control preamplifier of infrared signals. This device has features of low power, high sensitivity and wide supply voltage.

FEATURES

- Wide operation Voltage $V_{CC} = 6$ to 14.4 V
- Low Power Consumption $I_{CC} = 2.5$ mA TYP.
- High Input Sensitivity $50 \mu V_{p-p}$ TYP.
- Peak Detector
- Small Size Package 8 pin-SIP
- Minimum number of External parts required
- Designed for Use with the μ PD1913C, 1943G Remote Control Transmitter IC.

PACKAGE DIMENSIONS

in millimeters (inches)

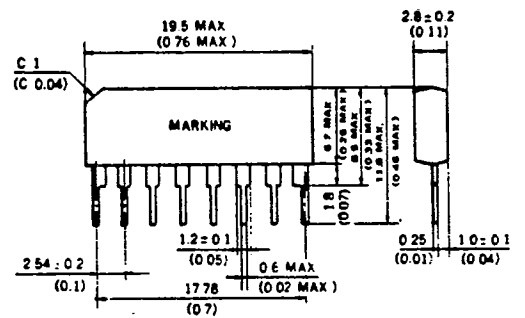

BLOCK DIAGRAM

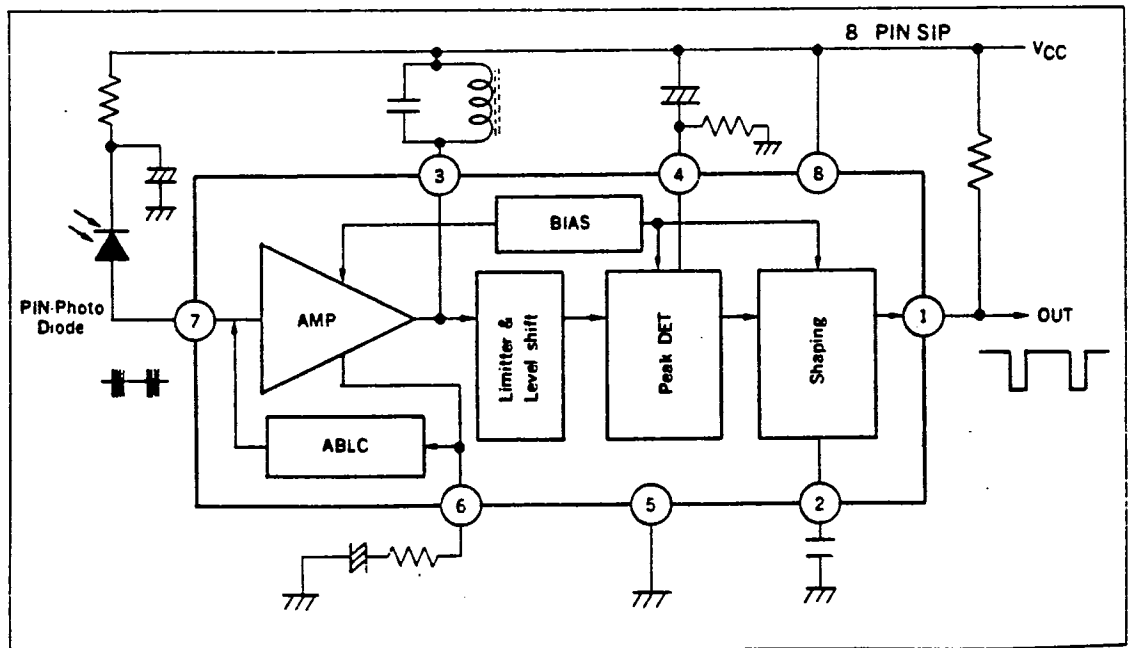

μPC1373H

ABSOLUTE MAXIMUM RATINGS (T_a = 25 °C)

Supply Voltage	V _{CC}	15	V
Power Dissipation	P _d	270	mW
Operating Temperature	T _{opt}	-20 to +75	°C
Storage Temperature	T _{stg}	-40 to +125	°C

RECOMENDED OPERATING CONDITIONS

CHARACTERISTIC	SYMBOL	MIN.	TYP.	MAX.	UNIT
Power Supply	V _{CC}	6.0	8.5	14.4	V
Input Frequency	f _{in}	30		50	kHz

ELECTRICAL CHARACTERISTICS (T_a = 25 °C, V_{CC} = 8.5 V, f_{in} = 40 kHz)

CHARACTERISTIC	SYMBOL	MIN.	TYP.	MAX.	UNIT	TEST CONDITIONS
Supply Current	I _{CC}	1.5	2.5	3.5	mA	
Input Terminal Voltage	V _{IN 1}	2.1	2.6	3.1	V	
Input Terminal Voltage	V _{IN 2}	3.4	4.1	4.9	V	I _{in} = 70 μA
1st Stage Voltage Gain	A _{VL}		60		dB	#7 - #3, U _{out} = 500 mVp-p
Detection Input Voltage	U _{in}		50	100	μV	
Input Impedance	r _{in}	40	60	80	kΩ	
Output Voltage	V _{OL}			0.5	V	I _{OL} = 0.1 mA, U _{in} = 1 mVp-p
Output Leak Current	I _{OH}			2	μA	V _{OH} = 14.4 V
Noise		Output Terminal is not fall.				Input Open

TEST CIRCUITS

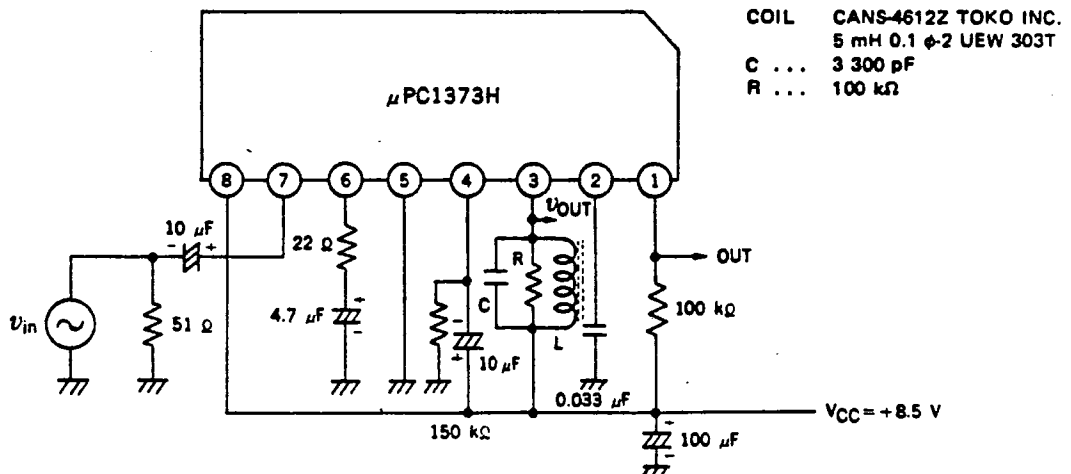

μPC1373H

STANDARD APPLICATION

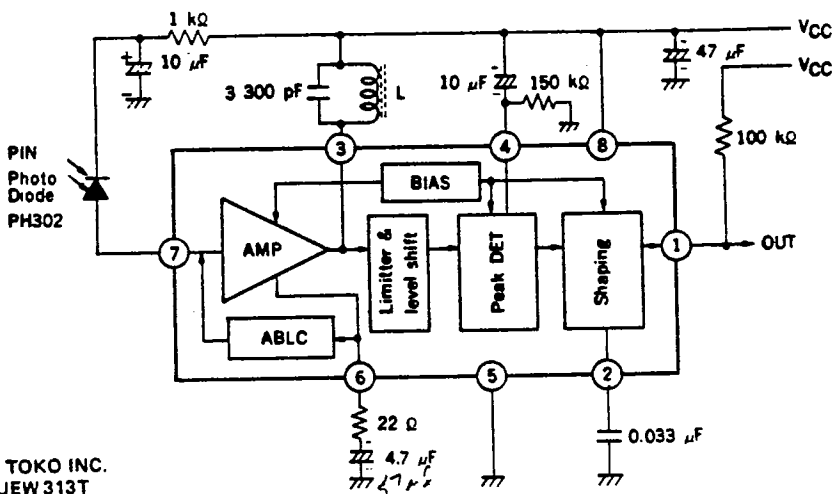

COIL 126LNS-6285Z TOKO INC.
5 mH 0.08 φ-2 UEW 313T

CONNECTION DIAGRAM

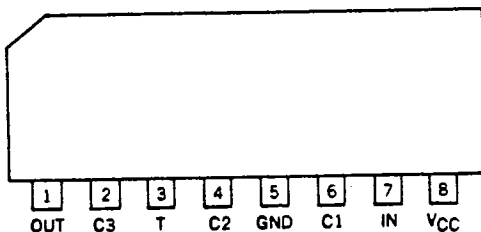

TERMINAL	1	2	3	4	5	6	7	8
	OUT	C3	T	C2	GND	C1	IN	VCC
	Output	Integral Capacitor	Tuning Coil	Peak Hold Capacitor	Ground	By-pass Capacitor	Input	Power Supply

PIN FUNCTION

- VCC Power Supply (#8)
Operation voltage is 6.0 to 14.4 V.
- IN Input (#7)
This input impedance is 60 kΩ typical.
This input has ABLC (Automatic Bias Level Control) circuit for not saturated by violent light, so this terminal voltage is always fixed.
- T Tuning coil (#3)
- C1 By-pass capacitor ... (#6)
This 1st amplifier has gain of 60 dB and this gain is determined of impedance of coil and external resistor R#6

Handwritten notes:
 $A_{VL} = \frac{Z_L}{R_{\#6}}$
 $\times \text{Log } 20$
 $Z_L = 200 \Omega$
 $R_{\#6} = 20 \times 10^3 \Omega$

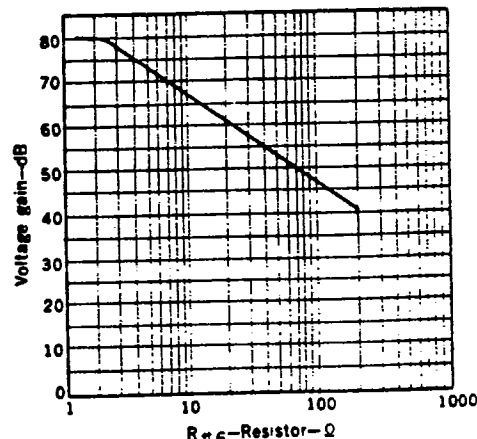

Fig. 1 1st stage amplitude gain

μPC1373H

○ C2 Peak hold capacitor . . (#4)

The signal of tuning coil terminal is detected by peak detector circuit. In this case, detecting level depend on input signal strength, so noise wave is suppressed. Time constant of peak hold is changed by capacitor C_{#4}, and sensitivity is adjusted by resistor R_{#4}. (see Fig. 2)

external resistor R_{#4}

- V_{CC} = 12 V ... 220 kΩ
- = 10 V ... 180 kΩ
- = 8.5 V ... 150 kΩ

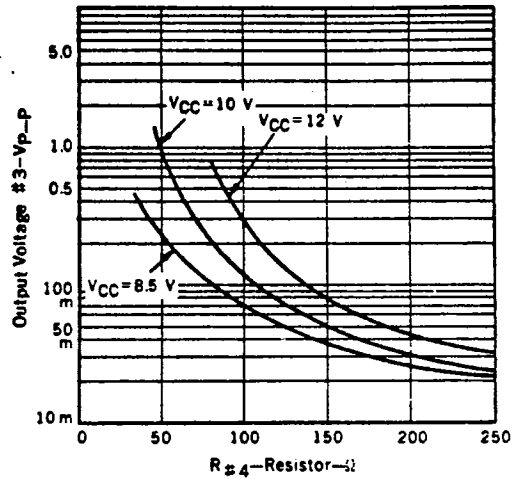

Fig. 2 Sensitivity of peak detector characteristic

○ C3 Integral Capacitor . . (#2)

Carrier wave through peak detector is integrated by this capacitor. This time constant is determined of external resistor R_{#1} and this capacitor C_{#2}.

○ OUT Output (#1)

Active Low output. This terminal is made of open collector transistor.

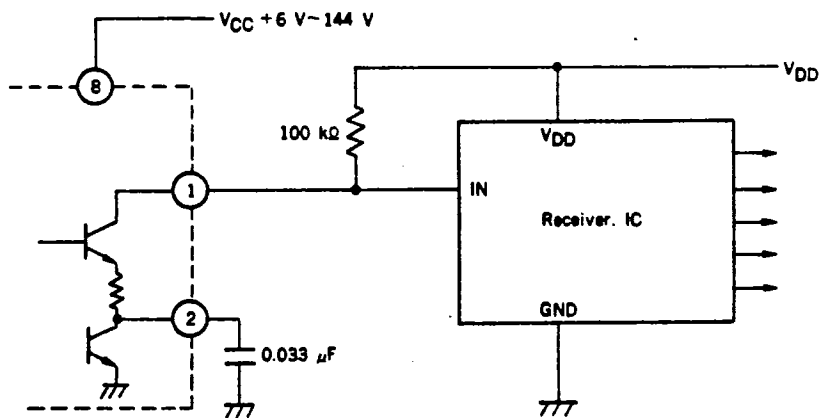

4

CHARACTERISTIC

VCC - ICC Characteristic

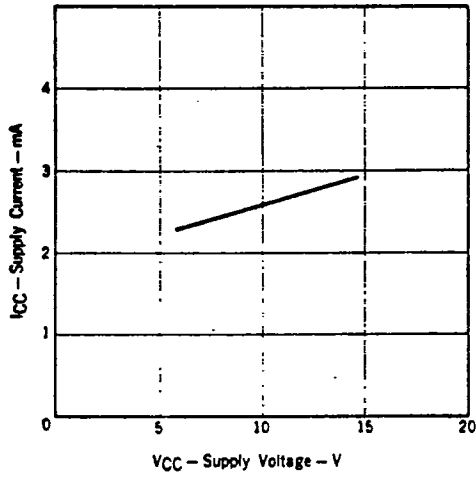

ABLC $I_{in} - V_{in}$ Characteristic

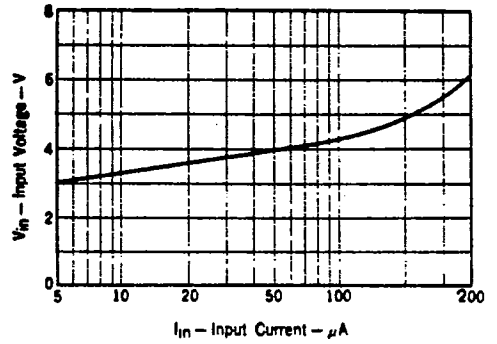

1st Stage $V_{in} - V_{OL}$ Characteristic

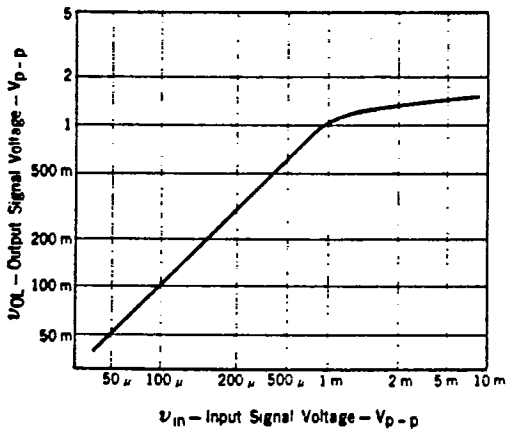

1st Stage $f_{in} - A_{VL}$ Characteristic

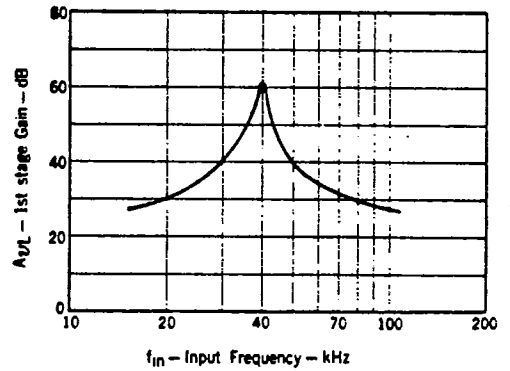

Output Saturation Voltage

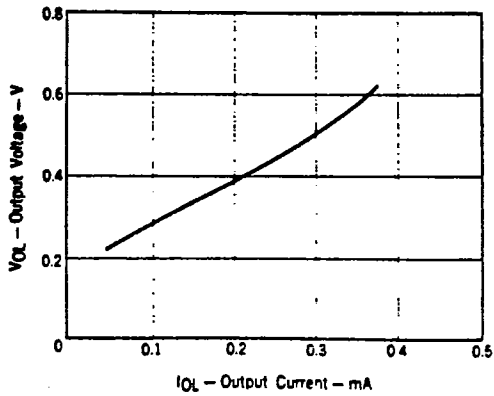

μPC1373H

APPLICATION

