

# VIF / SIF signal processor

## BA7357S

The BA7357S is a multi-format (M, B / G, D / K, and I) VIF / SIF signal processor for television and VCR applications. It features a built-in sound-trap and band-pass filters, and employs a pulse-count audio detector that does not require adjustment. This IC reduces external component requirements, and allows space savings.

### ●Applications

TVs and VCRs

### ●Features

- 1) Separate-carrier PLL with full synchronous detection. Excellent DG / DP, CS beat (920kHz) and cross color. In addition, by pulling down the SIF input (pin 9) it can be used as an intercarrier.
  - 2) The IF AGC time constant is dual-layered to allow faster speeds.
  - 3) The variable-gain amplifier has excellent linearity to ensure low distortion, and AGC variance and temperature drift have been minimized.
  - 4) Significant improvement in image quality through use of a filter that reduces CS beat.
  - 5) Built-in SOUND filter (4.5MHz SOUND Trap and 4.5MHz SOUND BPF).
- The MODE switch can be used to switch the SOUND filter frequency band to match the transmission format (M: 4.5, B / G: 5.5, I: 6.0, D / K: 6.5MHz).
- 6) The audio detector uses a pulse-counter detector that does not require adjustment, eliminating the need for a detector coil. Broad S-curve for multiplex broadcast compatibility.
  - 7) Use of pulse-counter detection and the built-in SOUND filter means fewer pins, external components and adjustment locations are required. The IC is available in a 22-pin SDIP package and will enable cost and space savings.

### ●Absolute maximum ratings (Ta = 25°C)

Parameter	Symbol	Limits	Unit
Applied voltage	V <sub>CCMax.</sub>	10.5*1	V
Power dissipation	Pd <sub>Max.</sub>	1250*2	mW
Operating temperature	T <sub>opr</sub>	- 15 ~ + 70	°C
Storage temperature	T <sub>stg</sub>	- 40 ~ + 150	°C
Pin 2 applied voltage	V <sub>P2Max.</sub>	10.5	V

\*1 24Ω resistor connected between V<sub>CC</sub> and V<sub>reg.</sub>

\*2 Reduced by 10mW for each increase in Ta 1°C over 25°C.

### ●Recommended operating conditions (Ta = 25°C)

Parameter	Symbol	Limits	Unit
Power supply voltage (9V)	V <sub>CC9V</sub>	8.8 ~ 9.2*1	V
Power supply voltage (12V)	V <sub>CC12V</sub>	11.7 ~ 12.3*2	V
Guaranteed operating power supply voltage	V <sub>CC</sub>	8.5 ~ 9.5*1	V

\*1 24Ω resistor connected between V<sub>CC</sub> and V<sub>reg.</sub>

\*2 56Ω resistor connected between V<sub>CC</sub> and V<sub>reg.</sub>

●Block diagram

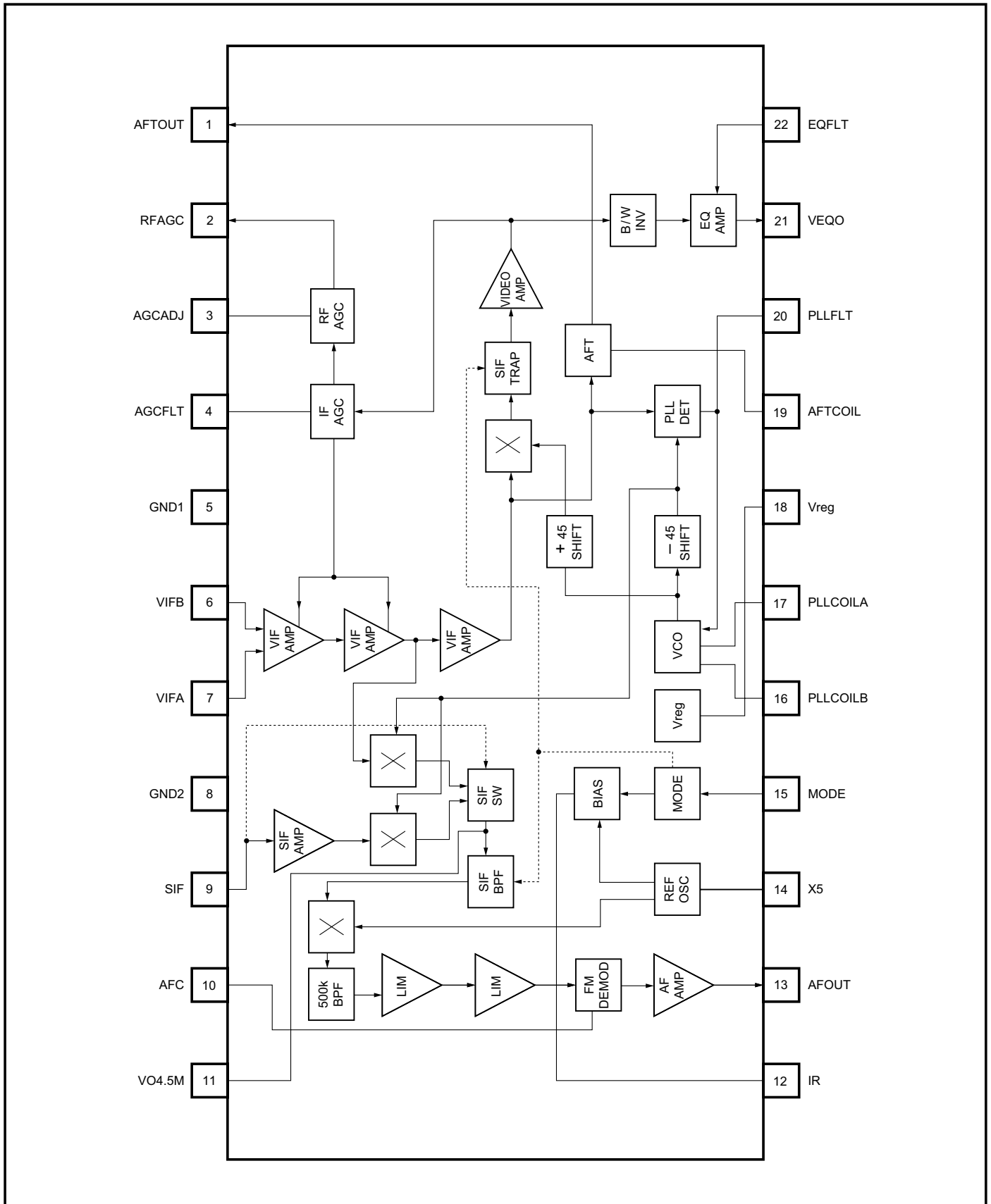

## ●Pin descriptions

Pin No.	Pin name	Function
1	AFTOUT	AFT OUT
2	RFAGC	RF AGC OUT
3	AGCADJ	RF AGC delay point adjustment
4	AGCFLT	IF AGC FILTER
5	GND1	VIF, BIAS GND
6	VIFB	VIF B IN
7	VIFA	VIF A IN
8	GND2	SIF, PLL GND
9	SIF	SIF IN / intercarrier SW
10	AFC	AUDIO detector Filter and A / V mute SW
11	VO4.5M	2nd SIF OUT
12	IR	Filter BIAS resistor ( ± 1%)
13	AFOUT	AUDIO OUT
14	X5	Filter system reference frequency oscillator
15	MODE	MODE SW
16	PLL COIL B	PLL oscillator COIL
17	PLL COIL A	PLL oscillator COIL
18	Vreg	Vreg
19	AFT COIL	AFT COIL
20	PLL FLT	PLL phase detect filter
21	VEQO	VIDEO OUT after EQ amplifier
22	EQFLT	EQ Filter

●Equivalent circuits

Pin No.	Pin name	IN / OUT	Standard voltage	Equivalent circuit	Function
1	AFTOUT	OUT	—		AFT output. Vreg / GND push-pull output.
2	RFAGC	OUT	—		RFAGC output. Open-collector output. Gain can be set using an external resistor (minimum value of the maximum sink current of pin 2 is 0.7mA) . Keep the pin 2 voltage at 10.5V or less.
3	AGCADJ	—	2.7V (when 100kΩ resistor connected)		RFAGC delay point adjustment. Connect to GND via a variable resistor (approx. 100kΩ).
4	AGCFLT	—	5.0V		For filter time constant for VIFAGC.
5	GND1	—	0V	—	GND terminal for VIF, AGC and AFT.

\* Vcc and Vcc2 in the equivalent circuit diagrams are connected to the Vreg terminal (pin 18).

Pin No.	Pin name	IN / OUT	Standard voltage	Equivalent circuit	Function
6 7	VIFB VIFA	IN	4.2V		Video IF input. Use with balanced input.
8	GND2	—	0V	—	SIF and PLL GND.
9	SIF	IN	6.6V		Audio IF input. Can set to intercarrier mode by pulling down via a 2kΩ resistor.
10	AFC	—	2.7V		Terminal for holding the audio output DC level fixed. Connect to GND via a 4.7μF capacitor and to Vreg via a 10μF capacitor to reduce BUZZ. Set this pin to 0.3V or lower to apply Audio / Video Mute.
11	VO4.5M	—	5.2V		2nd SIF output. Connect a Trap to this pin to vary the Sound Filter characteristics. The internal impedance is a high (Approximately) 1kΩ, so connect a Buffer to output.

Pin No.	Pin name	IN / OUT	Standard voltage	Equivalent circuit	Function
12	IR	—	2.4V		Reference current source for adjusting the internal filter. Use connected to GND via a 24kΩ resistor. Use an accurate resistor with good temperature characteristics (e.g. ± 1% metal film).
13	AFOUT	OUT	3.2V		Audio signal output. The standard output in the case of B / G is 520mV <sub>rms</sub> (when f = 50kHz). Connect to GND via a 10kΩ resistor.
14	X5	—	5.0V		For connection to a 5MHz oscillator (when M format is used). Use as a reference oscillator for automatic adjustment of the internal filter, and as the signal for the SIF signal low frequency conversion. (B / G, D / K format: 6MHz, I format: 6.5MHz).
15	MODE	IN	3.4V		Input terminal for Trap filter SW. 0V: M format (4.5MHz) 2.4V: D / K format (6.5MHz) 4.3V: I format (6.0MHz) Vreg: B / G format (5.5MHz)

Pin No.	Pin name	IN / OUT	Standard voltage	Equivalent circuit	Function
16 17	PLLCOILA PLLCOILB	—	3.6V		For connection of IF detector VCO oscillator coil.
18	Vreg	—	6.6V		IF circuit power supply. Pin 18 has a built-in shunt regulator.
19	AFTCOIL	—	3.0V		For connection of AFT coil. To apply AFT defeat, connect to GND via a 1kΩ (approx.) resistor.
20	PLLFLT	—	3.4V		Terminal for time constant circuit for the PLL filter.

Pin No.	Pin name	IN / OUT	Standard voltage	Equivalent circuit	Function
21	VEQO	OUT	2.0V (SYNC)		<p>VIDEO output. Output is via the Sound Trap, B / W noise inverter, and EQ amplifier. Connect to GND via a 4.7kΩ resistor.</p>
22	EQFLT	—	5.2V		<p>EG Filter. Connect to GND via an LCR series resonant circuit. R should be <math>\cong 1k\Omega</math>.</p>

●Electrical characteristics (unless otherwise noted, Ta = 25°C, V<sub>CC</sub> = 9V, and P = 38.9MHz)

Parameter	Symbol	Min.	Typ.	Max.	Unit	Conditions	
<b>&lt;Vreg&gt;</b>							
Supply current	I <sub>CC</sub>	—	96	110	mA		
Regulated voltage	V <sub>reg</sub>	6.2	6.6	7.0	V		
<b>&lt;VIF&gt;</b>							
Input sensitivity	V <sub>VMin.</sub>	34	40	46	dB $\mu$	V <sub>VO</sub> = - 3dB point	
Maximum allowable input level	V <sub>VMax.</sub>	100	110	—	dB $\mu$	V <sub>VO</sub> = + 1dB point	
AGC range	GR	62	70	—	dB	V <sub>VO</sub> = $\pm$ 3dB range	
Quiescent video output voltage	V <sub>P21</sub>	3.9	4.3	4.7	V	No signal, V <sub>P4</sub> = V <sub>reg</sub>	
Video detector output level	V <sub>VO</sub>	1.7	2.0	2.4	V <sub>P-P</sub>	V <sub>i</sub> = 80dB $\mu$ , AM87.5%MOD 100% white video signal	
Synchronous signal tip voltage	V <sub>P21SY</sub>	1.7	2.0	2.3	V		
Video output DG	DG	—	2	8	%	V <sub>i</sub> = 80dB $\mu$ , AM87.5%MOD 3STEP video signal	
Video output DP	DP	—	3	8	deg		
Sound trap attenuation	M, B / G	G <sub>VOS</sub>	33	45	—	dB	20*LOG (VOS / VO0.2M)
	D / K, I		28	45	—		
CS beat level	I <sub>920</sub>	37	50	—	dB	P = 0, P / C = 4, P / S = 14dB	
Video output S / N	S / N <sub>V</sub>	47	53	—	dB	V <sub>i</sub> = 90dB $\mu$ , 100% white	
White noise threshold voltage	V <sub>WTH</sub>	4.7	5.0	5.3	V	CW = 70dB $\mu$ frequency variation and pin 21 voltage variation	
White noise clamping voltage	V <sub>WCL</sub>	2.9	3.0	3.5	V		
Black noise threshold voltage	V <sub>BTH</sub>	1.1	1.4	1.7	V		
Black noise clamping voltage	V <sub>BCL</sub>	2.6	2.9	3.2	V		
RFAGC maximum sink current	I <sub>P2SI</sub>	0.7	1.2	—	mA	CW = 100dB $\mu$ , AGCADJ = 100K $\Omega$	
<b>&lt;AFT&gt;</b>							
Maximum AFT voltage	V <sub>PIMax.</sub>	6.0	6.4	—	V	CW = 38.4MHz	
Minimum AFT voltage	V <sub>PIMin.</sub>	—	0.3	0.8	V	CW = 39.4MHz	
AFT detection sensitivity	S <sub>f</sub>	35	65	—	mV / kHz	CW frequency variation	
AFT defeat starting voltage	V <sub>AFTDET</sub>	—	—	1.2	V	CW = 38.4MHz	
AFT defeat voltage	V <sub>IDEF</sub>	2.9	3.3	3.6	V	CW = 38.4MHz	
<b>&lt;PLL&gt;</b>							
PLL capture range 1	f <sub>CU</sub>	0.5	+ 0.9	—	MHz	CW = 80dB $\mu$ frequency variation	
PLL capture range 2	f <sub>CL</sub>	—	- 0.9	- 0.5	MHz		
PLL lock range 1	f <sub>LU</sub>	0.6	+ 2.0	—	MHz		
PLL lock range 2	f <sub>LL</sub>	—	- 2.0	- 0.6	MHz		
VCO control sensitivity	$\beta$	0.5	1.3	—	kHz / mV		

Parameter	Symbol	Min.	Typ.	Max.	Unit	Conditions
〈SIF〉 P = 38.9MHz / 80dB $\mu$ S = 33.4MHz / 70dB $\mu$ – 12dB (SAW Filter Loss)						
Input sensitivity	V <sub>SMin.</sub>	—	24	33	dB $\mu$	fm = 400Hz, $\Delta$ f = 50kHz
SIF maximum allowable input level	V <sub>SMax.</sub>	80	90	—	dB $\mu$	5% distortion
FM detector output level	V <sub>SO</sub>	350	520	700	mV <sub>rms</sub>	fm = 400Hz, $\Delta$ f = 50kHz
Audio output S / N	SN <sub>AF</sub>	52	64	—	dB	fm = 400Hz, $\Delta$ f = 50kHz
Audio output distortion	THD	—	0.3	1.5	%	fm = 400Hz, $\Delta$ f = 50kHz
AMR	AMR	40	56	—	dB	$\Delta$ f = 25kHz, AM30%
MUTE video output voltage	V <sub>VMUTE</sub>	—	0.7	1.2	V	V <sub>PIO</sub> = GND
MUTE audio output voltage	V <sub>SMUTE</sub>	2.3	2.9	3.5	V	V <sub>PIO</sub> = GND
MUTE start voltage	V <sub>IOMUTE</sub>	—	—	0.3	V	
Intermode switch voltage	V <sub>9INT</sub>	0.1	—	1.0	V	
VO4.5M output level	V <sub>VO4.5M</sub>	10	20	40	mV <sub>P-P</sub>	Intermode P = 80dB $\mu$ , P / S = 20dB (use FET probe)
〈MODE〉						
MODE voltage (M)	V <sub>15M</sub>	—	0	0.5	V	REF – OSC = 5MHz
MODE voltage (B / G)	V <sub>15BG</sub>	6.0	V <sub>reg</sub>	—	V	REF – OSC = 6MHz
MODE voltage (D / K)	V <sub>15DK</sub>	2.20	2.40	2.60	V	REF – OSC = 6MHz
MODE voltage (I)	V <sub>15I</sub>	4.10	4.30	4.50	V	REF – OSC = 6.5MHz

● Measurement circuit

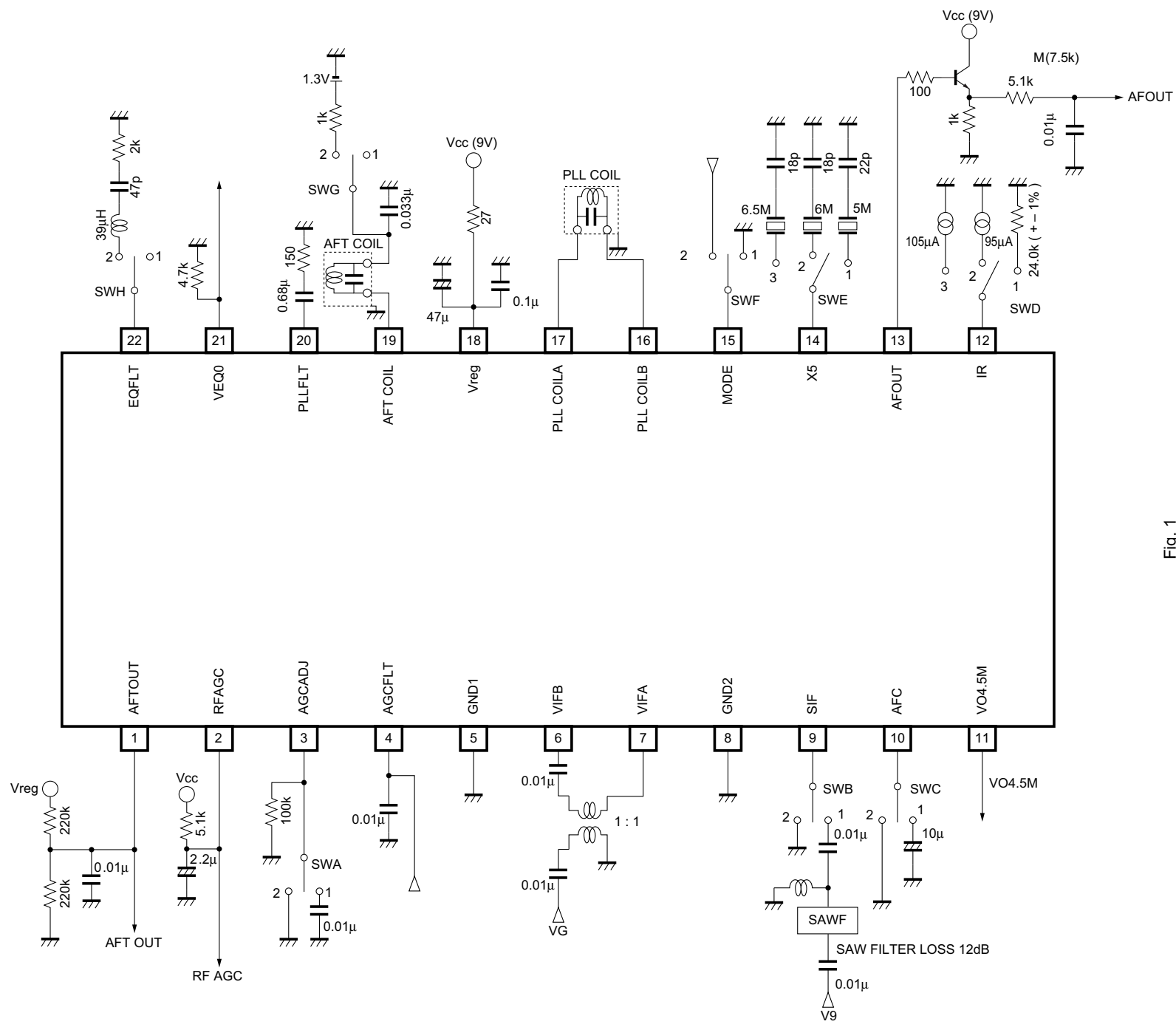

Fig. 1

● Application example

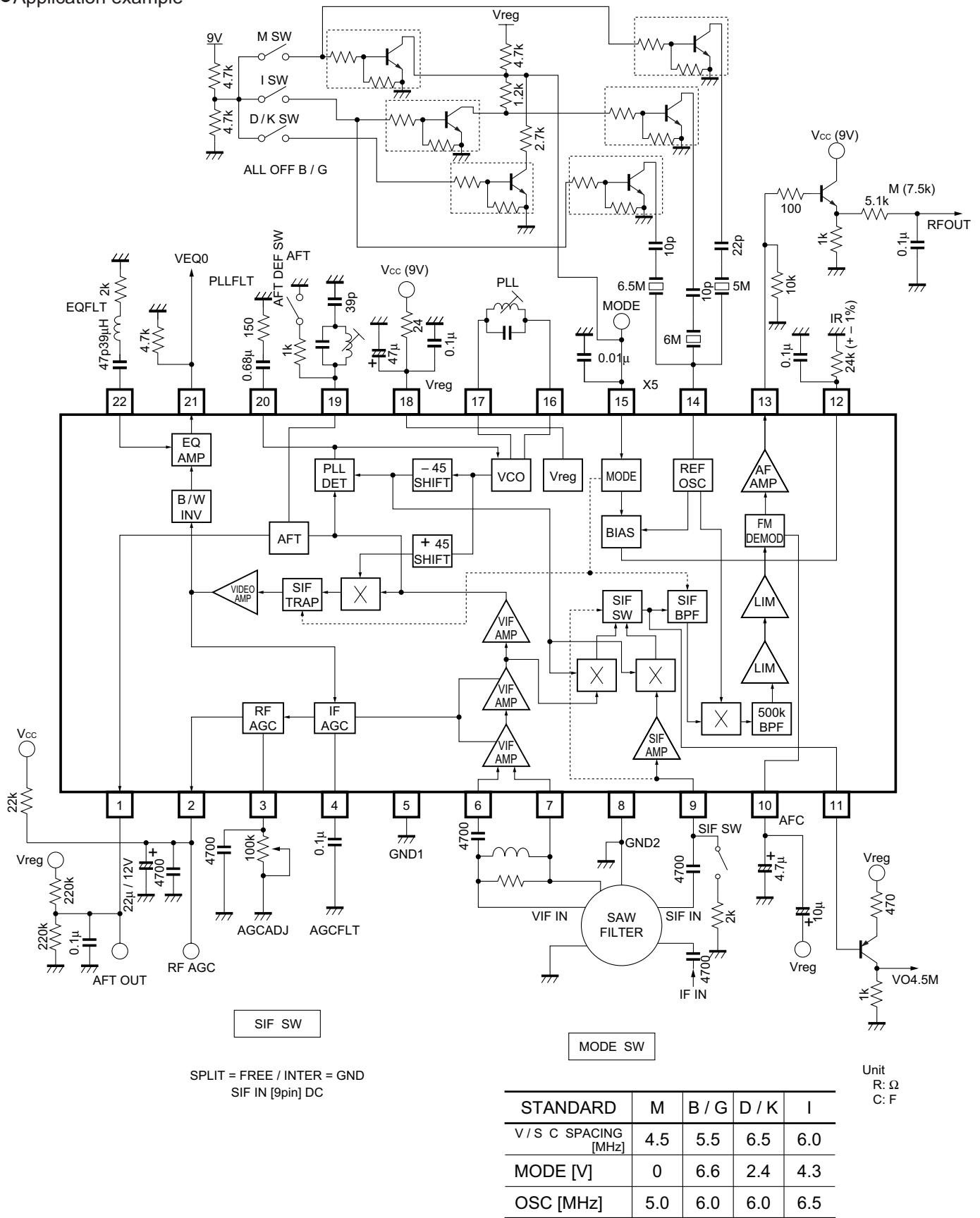
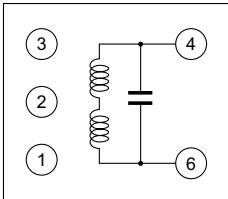
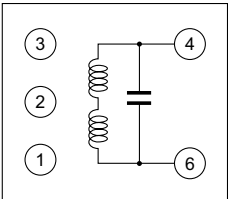
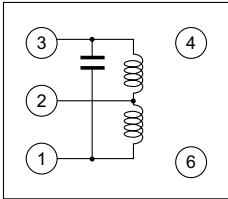
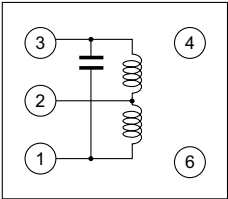

Fig. 2

AT Vreg = 6.6V

●Coil specifications

	f = 38.0MHz	f = 38.9MHz
VCO COIL	<p>0236 – JPS – 134 Type name: S-7GC</p>  <p>4 – 6 8T</p> <p>0.10φ</p> <p>Tuning capacitance: 22pF RH</p> <p>SUMIDA</p>	<p>0236 – JPS – 121 Type name: S-7GC</p>  <p>4 – 6 8T</p> <p>0.12φ</p> <p>Tuning capacitance: 22pF RH</p> <p>SUMIDA</p>
AFT COIL	<p>0236 – JPS – 137 Type name: S-7GC</p>  <p>1 – 2 2 – 3 3T 3T</p> <p>0.14φ</p> <p>Tuning capacitance: 56pF RH</p> <p>SUMIDA</p>	<p>0236 – JPS – 136 Type name: S-7GC</p>  <p>1 – 2 2 – 3 3T 3T</p> <p>0.10φ</p> <p>Tuning capacitance: 56pF RH</p> <p>SUMIDA</p>

Note: Connect a 16.7pF capacitor between 4 and 6 when measuring in the case of the VCO COIL.  
Connect a 0pF capacitor between 1 and 3 when measuring in the case of the AFT COIL.

●Operation notes

(1) Simultaneous audio and video output muting function

It is possible to simultaneously mute the audio and video output by pulling the AFC filter terminal down.

(2) AFT defeat function

AFT defeat can be applied by pulling the AFT coil terminal down via a 1kΩ resistor.

(3) Recommended SIF input range for intercarrier mode

P / S = 20 TO 30dB (including SAWFILTER).

(4) IF input range for RFAGC switching

60 TO 95dBμ.

(5) Intercarrier mode switching

Intercarrier mode can be set by pulling the SIF terminal down via a 2kΩ resistor.

(6) IR terminal external resistor

This resistor sets the filter system reference current, so use an accurate component that has good temperature characteristics.

●Electrical characteristic curves

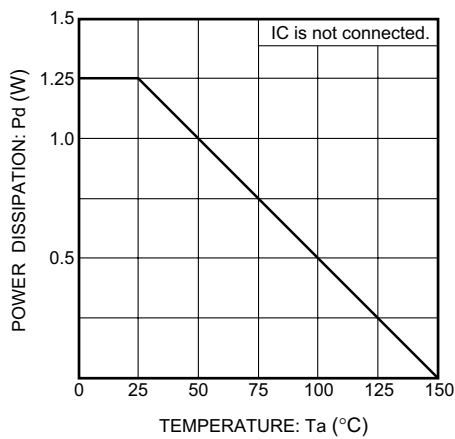

Fig. 3 Power dissipation

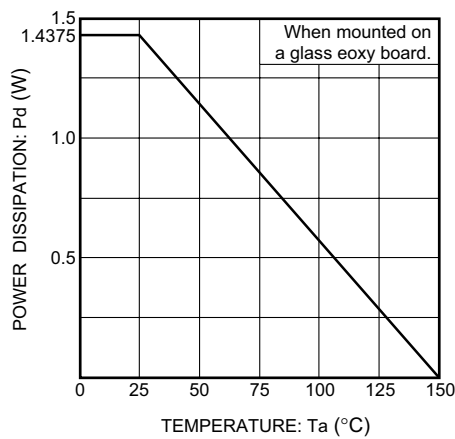

Fig. 4 Power dissipation

## ●External dimensions (Units: mm)

