

Silicon NPN Power Transistors

2SD2333

DESCRIPTION

- With TO-3PML package
- High breakdown voltage
- Built-in damper diode

APPLICATIONS

- Color TV horizontal deflection output applications

PINNING

PIN	DESCRIPTION
1	Base
2	Collector
3	Emitter

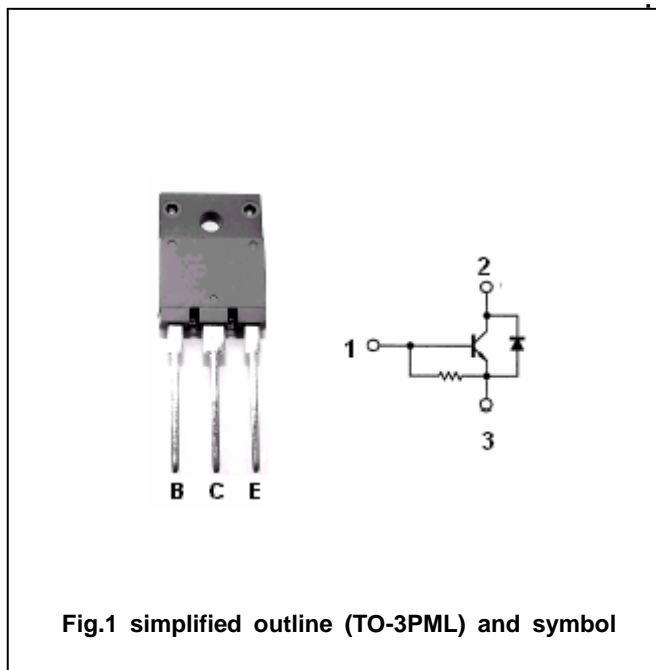

Fig.1 simplified outline (TO-3PML) and symbol

Absolute maximum ratings(Ta=25)

SYMBOL	PARAMETER	CONDITIONS	VALUE	UNIT
V_{CBO}	Collector-base voltage	Open emitter	1500	V
V_{CEO}	Collector-emitter voltage	Open base	600	V
V_{EBO}	Emitter-base voltage	Open collector	5	V
I_C	Collector current		5	A
I_{BM}	Base current-peak		2.5	A
P_C	Collector power dissipation	$T_C=25$	80	W
T_j	Junction temperature		150	
T_{stg}	Storage temperature		-55~150	

Silicon NPN Power Transistors

2SD2333

CHARACTERISTICS

T_j=25 unless otherwise specified

SYMBOL	PARAMETER	CONDITIONS	MIN	TYP.	MAX	UNIT
V _{CEO(SUS)}	Collector-emitter sustaining voltage	I _C =100mA; I _B =0	800			V
V _{(BR)EBO}	Emitter-base breakdown voltage	I _E =200mA, I _C =0	5			V
V _{CEsat}	Collector-emitter saturation voltage	I _C =4A; I _B =0.8A			5.0	V
V _{BEsat}	Base-emitter saturation voltage	I _C =4A; I _B =0.8A			1.5	V
I _{CBO}	Collector cut-off current	V _{CB} =500V; I _E =0			10	μA
h _{FE}	DC current gain	I _C =1A; V _{CE} =5V	8			
V _F	Diode forward voltage	I _F =5A			2.0	V

固电半导体
INCHANGE SEMICONDUCTOR

Silicon NPN Power Transistors

2SD2333

PACKAGE OUTLINE

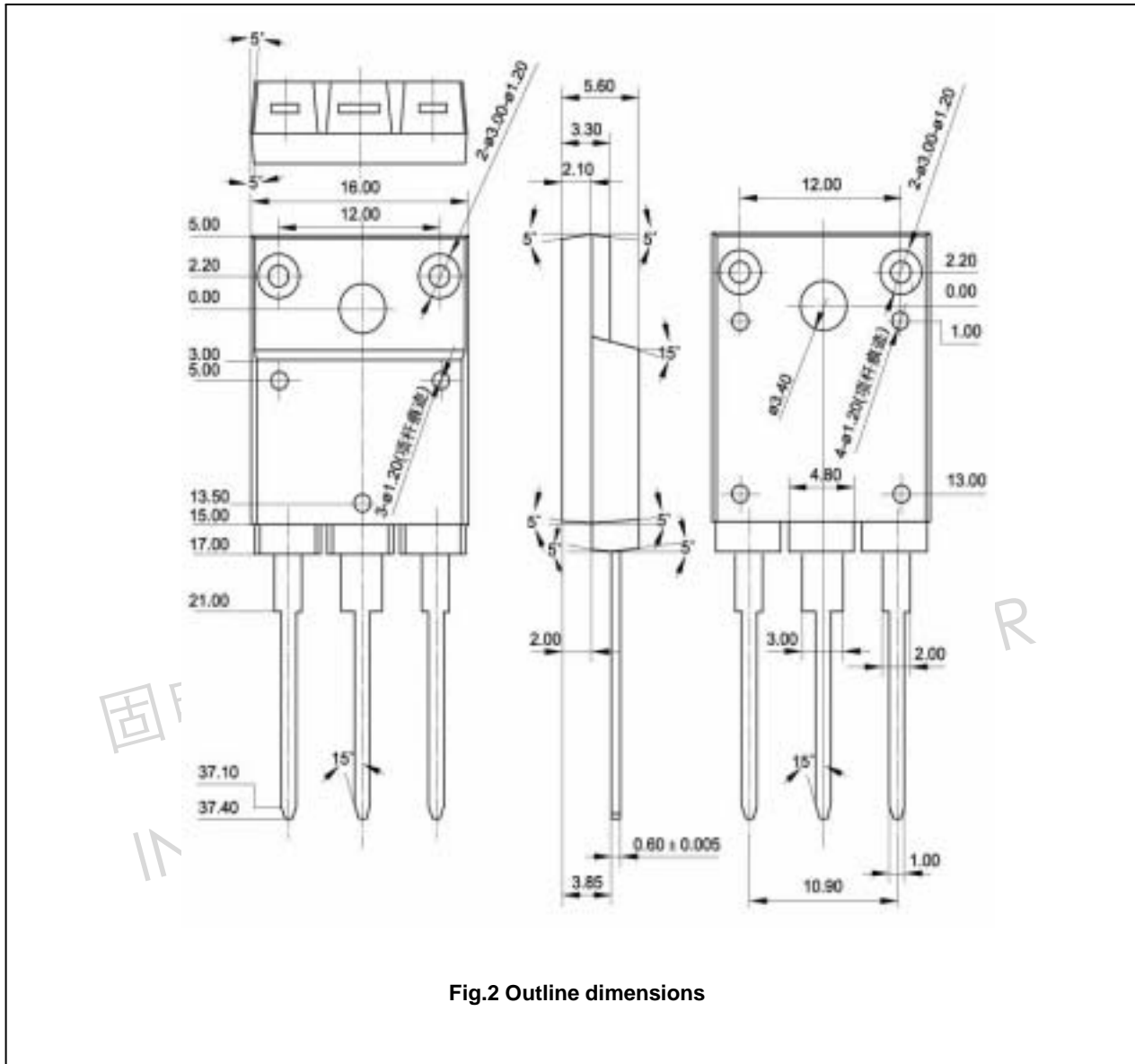

Fig.2 Outline dimensions