

AN7213

FM Front-end Circuit for Radio

■ Description

The AN7213 is a monolithic integrated circuit designed for FM front-end of the portable radio.

■ Features

- Built-in RF amplifier, frequency converter, local oscillator
- Wide operating voltage range: 2V~ 7V
- Low current consumption: 2mA ($V_{CC} = 4V$)

■ Pin

Pin No.	Pin Name
1	RF Input
2	V_{CC}
3	RF Output
4	GND
5	Mixer Output
6	Oscillator Collector
7	Oscillator Emitter

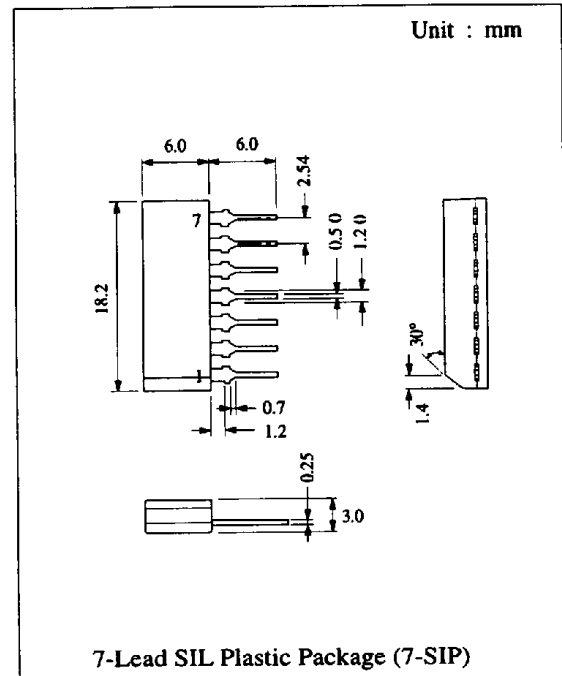

■ Block Diagram

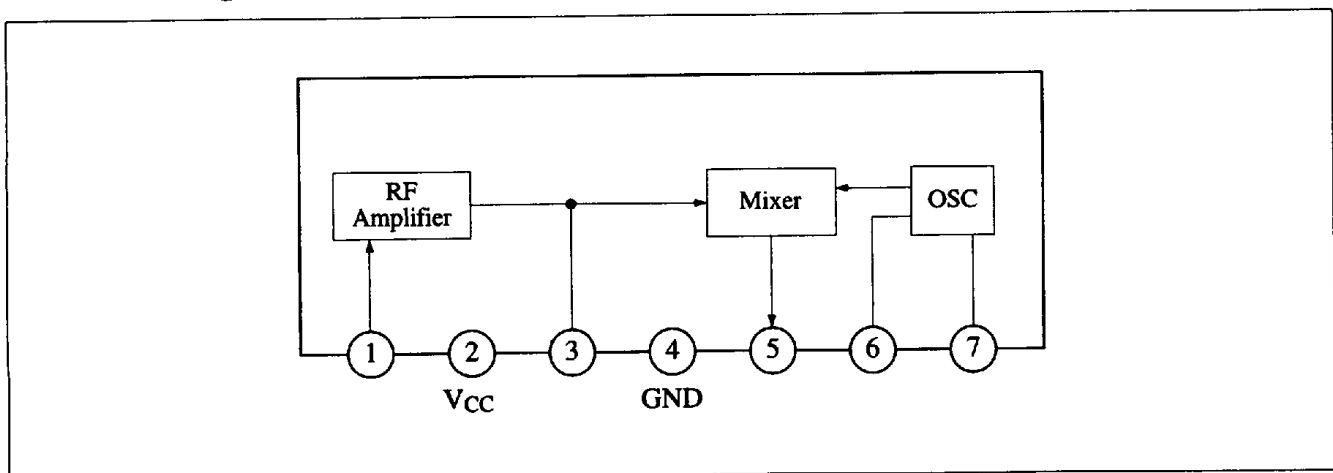

■ Absolute Maximum Ratings (Ta=25°C)

Item	Symbol	Rating	Unit
Supply Voltage	V _{CC}	7	V
Terminal Voltage	V ₃₋₄	14	V
	V ₅₋₄	14	V
	V ₆₋₄	14	V
Power Dissipation	P _D	30	mW
Operating Ambient Temperature	T _{opr}	-20 ~ +75	°C
Storage Temperature	T _{stg}	-55 ~ +125	°C

Operating Supply Voltage Range: V_{CC} = 2.0V ~ 7.0V

■ Electrical Characteristics (Ta=25°C)

Item	Symbol	Test Circuit	Condition	min.	typ.	max.	Unit
Quiescent Current	I _{CQ}	1	V _{CC} = 4V, without signal	1.4		2.55	mA
Output Voltage	V _O	2	V _{CC} = 4V, V _{in} = 70dBμ, 106MHz*	30.5		68.5	mV
Local Oscillation Voltage	V _{osc}	2	V _{CC} = 2V	130			mV

* Max. output voltage value is obtained by changing input signal frequency ±Δf at 106MHz

Test Circuit 1 (I_{tot})

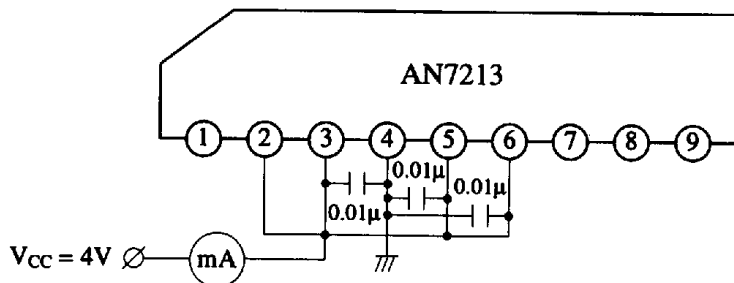

Test Circuit 2 (V_O, V_{OSC})

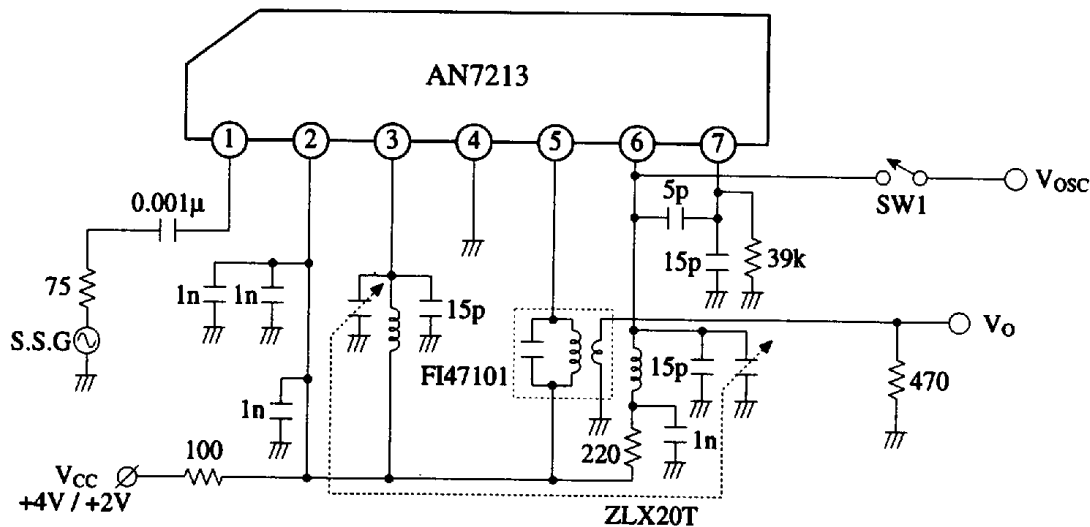

■ Application Circuit

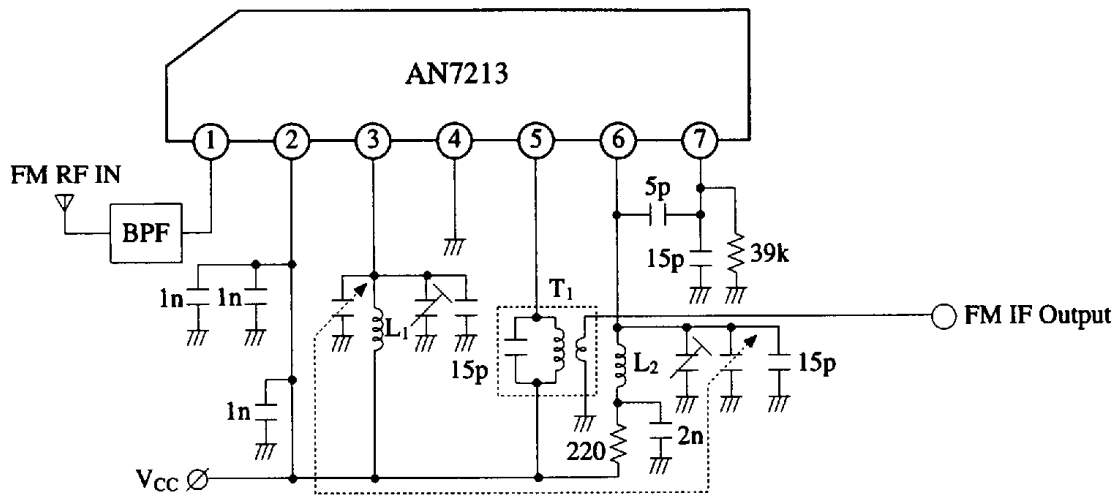

■ Characteristics Curve

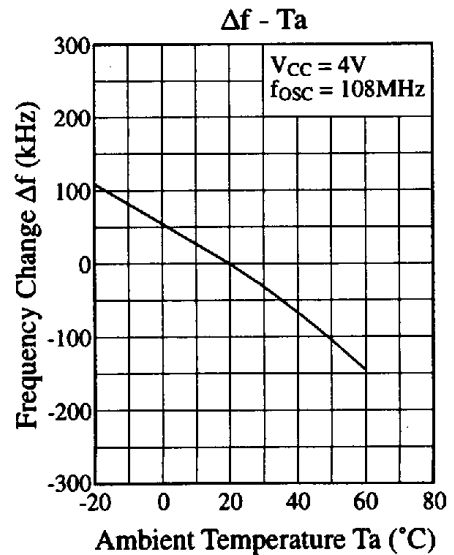
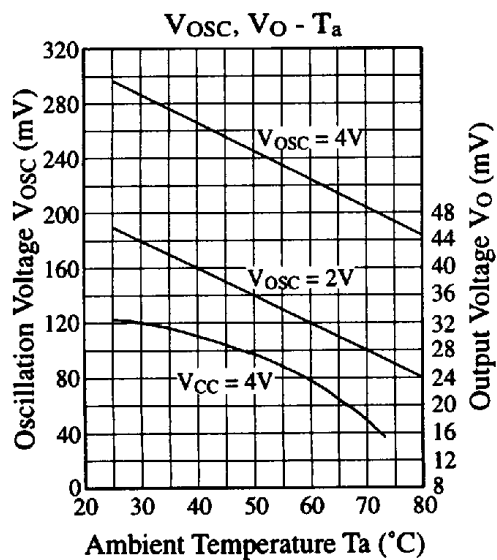
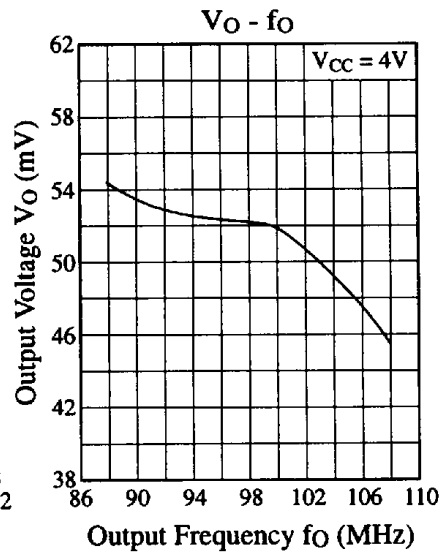
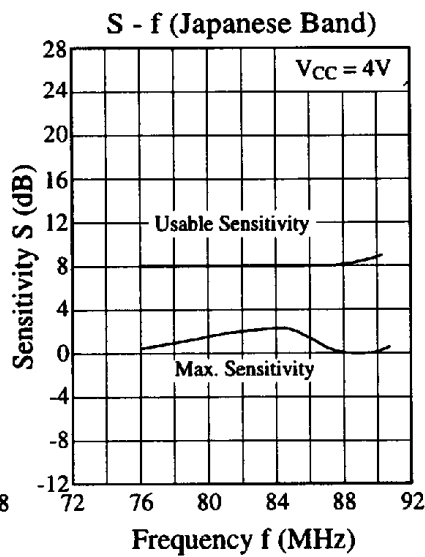
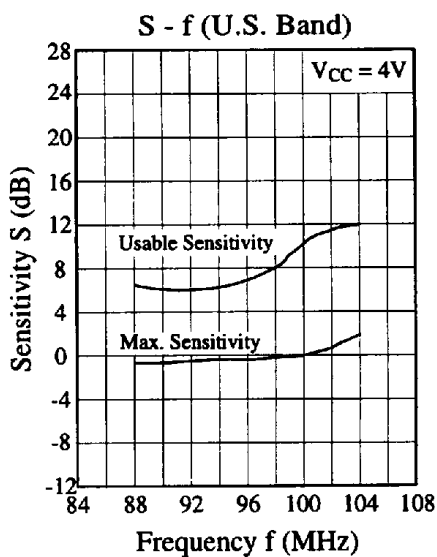

■ Coil Specifications

Symbol	Use, Freq.	Type No.	Maker	Connection Diagram	Number of Turns	Tuning Cap.	Unloaded Q
T ₁	FM Quad Coil 10.7MHz	EIF-7S752A	Matsushita		①...② 8T ②...③ 5T ④...⑥ 2T	100pF	90
L ₁	RF Coil 76 ~ 108MHz	ELQ-5N53	Matsushita		Ⓢ...ⓕ 2.5T	0.0986μH	110 (at 25.2MHz)
L ₂	OSC Coil	ELQ-5N111	Matsushita		Ⓢ...ⓕ 1.75T	0.0495μH	150 (at 25.2MHz)

■ Printed Circuit Board Layout (Scale: 1:1)

