

DATA SHEET

TDA4555

TDA4556

Multistandard decoder

Product specification
File under Integrated Circuits, IC02

November 1984

Multistandard decoder**TDA4555**
TDA4556**GENERAL DESCRIPTION**

The TDA4555 and TDA4556 are monolithic integrated multistandard colour decoders for the PAL, SECAM, NTSC 3,58 MHz and NTSC 4,43 MHz standards. The difference between the TDA4555 and TDA4556 is the polarity of the colour difference output signals (B-Y) and (R-Y).

Features**Chrominance part**

- Gain controlled chrominance amplifier for PAL, SECAM and NTSC
- ACC rectifier circuits (PAL/NTSC, SECAM)
- Burst blanking (PAL) in front of 64 μ s glass delay line
- Chrominance output stage for driving the 64 μ s glass delay line (PAL, SECAM)
- Limiter stages for direct and delayed SECAM signal
- SECAM permutator

Demodulator part

- Flyback blanking incorporated in the two synchronous demodulators (PAL, NTSC)
- PAL switch
- Internal PAL matrix

- Two quadrature demodulators with external reference tuned circuits (SECAM)
- Internal filtering of residual carrier
- De-emphasis (SECAM)
- Insertion of reference voltages as achromatic value (SECAM) in the (B-Y) and (R-Y) colour difference output stages (blanking)

Identification part

- Automatic standard recognition by sequential inquiry
- Delay for colour-on and scanning-on
- Reliable SECAM identification by PAL priority circuit
- Forced switch-on of a standard
- Four switching voltages for chrominance filters, traps and crystals
- Two identification circuits for PAL/SECAM (H/2) and NTSC
- PAL/SECAM flip-flop
- SECAM identification mode switch (horizontal, vertical or combined horizontal and vertical)
- Crystal oscillator with divider stages and PLL circuitry (PAL, NTSC) for double colour subcarrier frequency
- HUE control (NTSC)
- Service switch

QUICK REFERENCE DATA

Supply voltage (pin 13)	$V_P = V_{13-9}$	typ.	12	V
Supply current (pin 13)	$I_P = I_{13}$	typ.	65	mA
Chrominance input signal (peak-to-peak)	$V_{15-9(p-p)}$	20 to 200		mV
Chrominance output signal (peak-to-peak)	$V_{12-9(p-p)}$	typ.	1,6	V
Colour difference output signals (peak-to-peak values)				
TDA4555: -(R-Y); TDA4556: + (R-Y)	$V_{1-9(p-p)}$	typ.	1,05	$V \pm 2$ dB
TDA4555: -(B-Y); TDA4556: + (B-Y)	$V_{3-9(p-p)}$	typ.	1,33	$V \pm 2$ dB
Sandcastle pulse; required amplitude for				
vertical and horizontal pulse separation	V_{24-9}	typ.	2,5	V
horizontal pulse separation	V_{24-9}	typ.	4,5	V
burst gating	V_{24-9}	typ.	7,7	V

PACKAGE OUTLINE

28-lead DIL; plastic (SOT117); SOT 117-1; 1996 November 27.

Multistandard decoder

TDA4555
TDA4556

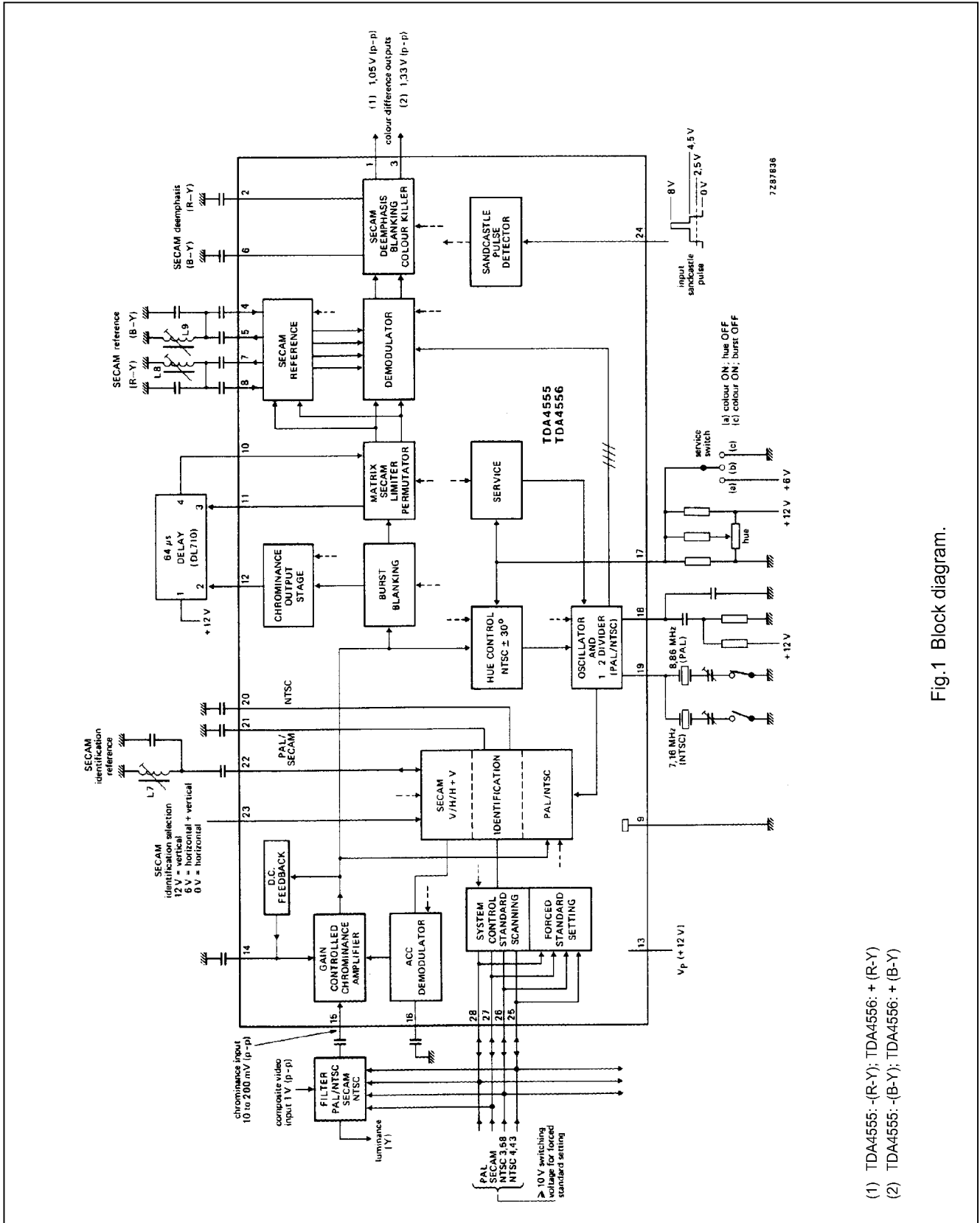

- (1) TDA4555: -(R-Y); TDA4556: + (R-Y)
- (2) TDA4555: -(B-Y); TDA4556: + (B-Y)

Fig.1 Block diagram.

Multistandard decoder

TDA4555
TDA4556**RATINGS**

Limiting values in accordance with the Absolute Maximum System (IEC 134)

Supply voltage (pin 13)	$V_P = V_{13-9}$	max.	13,2	V
Voltage range at pins 10, 11, 17, 23, 24, 25, 26, 27, 28 to pin 9 (ground)	V_{n-9}		0 to V_P	V
Current at pin 12	I_{12}	max.	8	mA
Peak value	I_{12M}	max.	15	mA
Total power dissipation	P_{tot}	max.	1,4	W
Storage temperature range	T_{stg}		-25 to + 150	°C
Operating ambient temperature range	T_{amb}		0 to + 70	°C

Multistandard decoder

TDA4555
TDA4556**CHARACTERISTICS** $V_P = V_{13-9} = 12\text{ V}$; $T_{\text{amb}} = 25\text{ }^\circ\text{C}$; measured in Fig.1; unless otherwise specified

PARAMETER	SYMBOL	MIN.	TYP.	MAX.	UNIT
Supply (pin 13)					
Supply voltage range	$V_P = V_{13-9}$	10,8	–	13,2	V
Supply current	$I_P = I_{13}$	–	65	–	mA
Chrominance part					
Chrominance input signal (pin 15)					
input voltage with 75% colour bar signal (peak-to-peak value)	$V_{15-9(p-p)}$	20	100	200	mV
input impedance	$ Z_{15-9} $	2,3	3,3	–	k Ω
Chrominance output signal (pin 12)					
output voltage (peak-to-peak value)	$V_{12-9(p-p)}$	–	1,6	–	V
output impedance (n-p-n emitter follower)	$ Z_{12-9} $	–	–	20	Ω
d.c. output voltage	V_{12-9}	–	8,2	–	V
Input for delayed signal (pin 10)					
d.c. input current	I_{10}	–	–	10	μA
input resistance	R_{10-9}	10	–	–	k Ω
Demodulator part (PAL/NTSC)					
Colour difference output signals					
output voltage (proportional to V_{13-9}) (peak-to-peak value)					
TDA4555					
– (R-Y) signal (pin 1)	$V_{1-9(p-p)}$	–	$1,05\text{ V} \pm 2\text{ dB}$	–	V
– (B-Y) signal (pin 3)	$V_{3-9(p-p)}$	–	$1,33\text{ V} \pm 2\text{ dB}$	–	V
TDA4556					
+ (R-Y) signal (pin 1)	$V_{1-9(p-p)}$	–	$1,05\text{ V} \pm 2\text{ dB}$	–	V
+ (B-Y) signal (pin 3)	$V_{3-9(p-p)}$	–	$1,33\text{ V} \pm 2\text{ dB}$	–	V
Ratio of colour difference output signals (R-Y)/(B-Y)					
	$V_{1/3-9}$	–	$0,79 \pm 10\%$	–	
Residual carrier (subcarrier frequency) (peak-to-peak value)					
	$V_{1,3-9(p-p)}$	–	–	30	mV
Residual carrier (PAL only) (peak-to-peak value)					
	$V_{1,3-9(p-p)}$	–	10	–	mV
H/2 ripple at (R-Y) output (pin 1) (peak-to-peak value) without input signal					
	$V_{1-9(p-p)}$	–	–	10	mV
D.C. output voltage					
n-p-n emitter follower with internal current source of 0,3 mA	$V_{1,3-9}$	–	7,7	–	V
output impedance	$ Z_{1,3-9} $	–	–	150	Ω

Multistandard decoder

TDA4555
TDA4556

PARAMETER	SYMBOL	MIN.	TYP.	MAX.	UNIT
Demodulator part (SECAM)					
Colour difference signals (see note 4)					
output voltage (proportional to V_{13-9}) (peak-to-peak value)					
TDA4555					
–(R-Y) signal (pin 1)	$V_{1-9(p-p)}$	–	1,05	–	V
– (B-Y) signal (pin 3)	$V_{3-9(p-p)}$	–	1,33	–	V
TDA4556					
+ (R-Y) signal (pin 1)	$V_{1-9(p-p)}$	–	1,05	–	V
+ (B-Y) signal (pin 3)	$V_{3-9(p-p)}$	–	1,33	–	V
Ratio of colour difference output signals					
(R-Y)/(B-Y)	$V_{1/3-9}$	–	$0,79^{(1)} \pm 10\%$	–	
Residual carrier (4 to 5 MHz)					
(peak-to-peak value)	$V_{1,3-9(p-p)}$	–	20	30	mV
Residual carrier (8 to 10 MHz)					
(peak-to-peak value)	$V_{1,3-9(p-p)}$	–	20	30	mV
H/2 ripple					
at (R-Y) (B-Y) outputs (pins 1 and 3) (peak-to-peak value) with f_0 signals	$V_{1,3-9(p-p)}$	–	–	20	mV
D.C. output voltage					
	$V_{1,3-9}$	–	7,7	–	V
Shift of inserted levels relative to levels of demodulated f_0 frequencies (IC only)					
	$\Delta V/\Delta T(R-Y)$	–	–0,55	–	mV/K
	$\Delta V/\Delta T(B-Y)$	–	+ 0,25	–	mV/K
HUE control (NTSC)/service switch					
Phase shift of reference carrier					
at $V_{17-9} = 2\text{ V}$	$-\phi$	–	30 (note 2)	–	deg
at $V_{17-9} = 3\text{ V}$	ϕ	–	0	–	deg
at $V_{17-9} = 4\text{ V}$	$+\phi$	–	30 (note 2)	–	deg
Input resistance					
	R_{17-9}	–	5	–	k Ω
Service position					
Switching voltage (pin 17)					
burst OFF; colour ON (for oscillator adjustment)	V_{17-9}	–	–	0,5	V
HUE control OFF; colour ON (for forced colour ON)	V_{17-9}	6	–	–	V
Crystal oscillator (pin 19)					
For double colour subcarrier frequency					
input resistance	R_{19-9}	–	350	–	Ω
lock-in-range referred to subcarrier frequency	Δf	± 400	–	–	Hz

Multistandard decoder

TDA4555
TDA4556

PARAMETER	SYMBOL	MIN.	TYP.	MAX.	UNIT
Identification part					
Switching voltages for chrominance filters and crystals					
at pin 28 (PAL)					
at pin 27 (SECAM)					
at pin 26 (NTSC 3,58 MHz)					
at pin 25 (NTSC 4,43 MHz)					
Control voltage OFF state	$V_{25,26,27,28-9}$	–	–	0,5	V
Control voltage ON state					
during scanning; colour OFF	$V_{25,26,27,28-9}$	–	2,45	–	V
colour ON	$V_{25,26,27,28-9}$	–	5,8	–	V
Output current	$-I_{25,26,27,28-9}$	–	–	3	mA
Voltage for forced switching ON					
PAL	V_{28-9}	9	–	–	V
SECAM	V_{27-9}	9	–	–	V
NTSC 3,58 MHz	V_{26-9}	9	–	–	V
NTSC 4,43 MHz	V_{25-9}	9	–	–	V
Delay time for					
restart of scanning	t_{dS}		2 to 3 vertical periods		
colour ON	t_{dC1}		2 to 3 vertical periods		
colour OFF	t_{dC2}		0 to 1 vertical periods		
SECAM identification (pin 23)					
Input voltage for					
horizontal identification (H)	V_{23-9}	–	–	2	V
vertical identification (V)	V_{23-9}	10	–	–	V
combined (H) and (V) identification	V_{23-9}	–	6 (note 3)	–	V
Sequence of standard inquiry					
PAL-SECAM-NTSC 3,58 MHz-NTSC 4,43 MHz					
Reliable SECAM identification by PAL priority circuit					
Scanning time for each standard	t_S		4 vertical periods		

Multistandard decoder

TDA4555
TDA4556

PARAMETER	SYMBOL	MIN.	TYP.	MAX.	UNIT
Sandcastle pulse detector (see note 5)					
Input voltage pulse levels (pin 24)					
to separate vertical and horizontal blanking pulses	V_{24-9}	1,2	–	2,0	V
required pulse amplitude	$V_{24-9(p-p)}$	2,0	–	3,0	V
to separate horizontal blanking pulse	V_{24-9}	3,2	–	4,0	V
required pulse amplitude	$V_{24-9(p-p)}$	4,0	–	5,0	V
to separate burst gating pulse	V_{24-9}	6,5	–	7,7	V
required pulse amplitude	$V_{24-9(p-p)}$	7,7	–	V_P	V
Input voltage during horizontal scanning	V_{24-9}	–	–	1,0	V
Input current	$-I_{24}$	–	–	100	μA

Notes

1. Value measured without influence of external circuitry.
2. Relative to phase at $V_{17-9} = 3 V$.
3. Or not connected.
4. The signal amplitude of the colour difference signals (R-Y) and (B-Y) is dependent on the characteristics of the external tuned circuits at pins 7, 8 and 4, 5 respectively. Adjustment of the amplitude is achieved by varying the Q-factor of these tuned circuits. The resonant frequency must be adjusted such that the demodulated output frequency (f_o) provides the same output level as the internally inserted reference voltage (achromatic value).
5. The sandcastle pulse is compared with three internal threshold levels, which are proportional to the supply voltage.

Multistandard decoder

TDA4555
TDA4556

APPLICATION INFORMATION

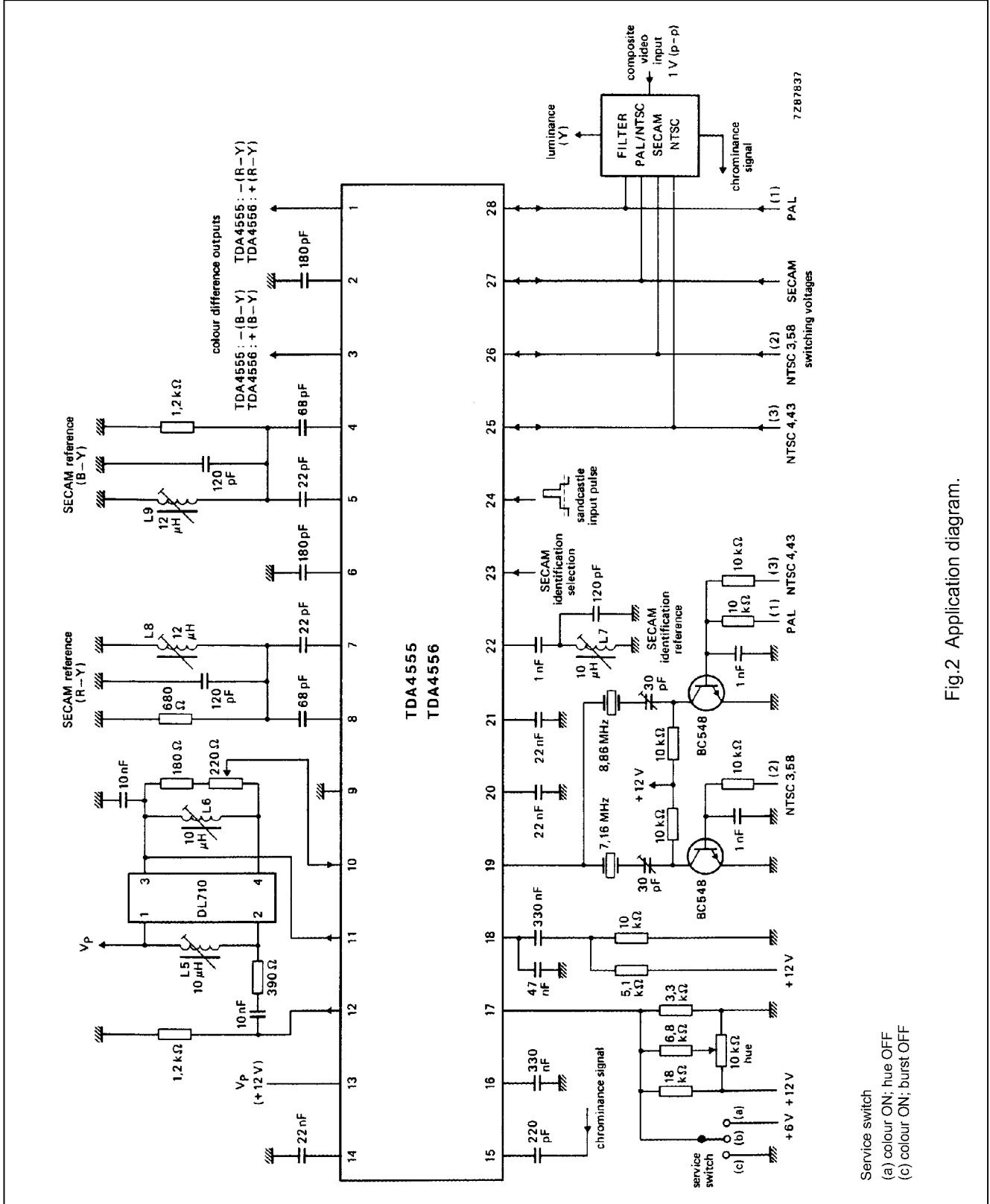

Fig.2 Application diagram.

Service switch
(a) colour ON; hue OFF
(c) colour ON; burst OFF

Multistandard decoder

TDA4555
TDA4556

PACKAGE OUTLINE

DIP28: plastic dual in-line package; 28 leads (600 mil)

SOT117-1

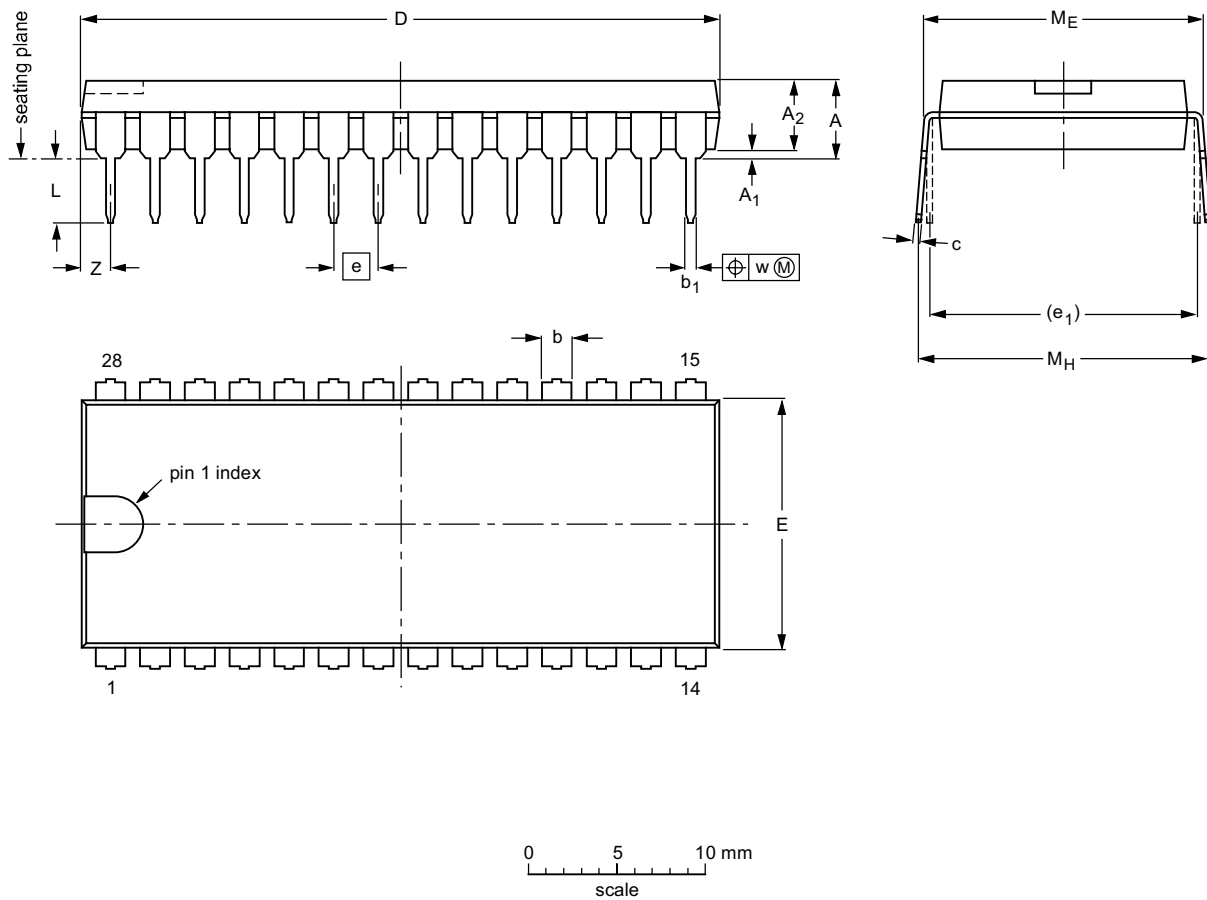

DIMENSIONS (inch dimensions are derived from the original mm dimensions)

UNIT	A max.	A ₁ min.	A ₂ max.	b	b ₁	c	D ⁽¹⁾	E ⁽¹⁾	e	e ₁	L	M _E	M _H	w	Z ⁽¹⁾ max.
mm	5.1	0.51	4.0	1.7 1.3	0.53 0.38	0.32 0.23	36.0 35.0	14.1 13.7	2.54	15.24	3.9 3.4	15.80 15.24	17.15 15.90	0.25	1.7
inches	0.20	0.020	0.16	0.066 0.051	0.020 0.014	0.013 0.009	1.41 1.34	0.56 0.54	0.10	0.60	0.15 0.13	0.62 0.60	0.68 0.63	0.01	0.067

Note

1. Plastic or metal protrusions of 0.25 mm maximum per side are not included.

OUTLINE VERSION	REFERENCES				EUROPEAN PROJECTION	ISSUE DATE
	IEC	JEDEC	EIAJ			
SOT117-1	051G05	MO-015AH				92-11-17 95-01-14

Multistandard decoder

TDA4555
TDA4556

SOLDERING

Introduction

There is no soldering method that is ideal for all IC packages. Wave soldering is often preferred when through-hole and surface mounted components are mixed on one printed-circuit board. However, wave soldering is not always suitable for surface mounted ICs, or for printed-circuits with high population densities. In these situations reflow soldering is often used.

This text gives a very brief insight to a complex technology. A more in-depth account of soldering ICs can be found in our "IC Package Databook" (order code 9398 652 90011).

Soldering by dipping or by wave

The maximum permissible temperature of the solder is 260 °C; solder at this temperature must not be in contact with the joint for more than 5 seconds. The total contact time of successive solder waves must not exceed 5 seconds.

The device may be mounted up to the seating plane, but the temperature of the plastic body must not exceed the specified maximum storage temperature ($T_{stg\ max}$). If the printed-circuit board has been pre-heated, forced cooling may be necessary immediately after soldering to keep the temperature within the permissible limit.

Repairing soldered joints

Apply a low voltage soldering iron (less than 24 V) to the lead(s) of the package, below the seating plane or not more than 2 mm above it. If the temperature of the soldering iron bit is less than 300 °C it may remain in contact for up to 10 seconds. If the bit temperature is between 300 and 400 °C, contact may be up to 5 seconds.

DEFINITIONS

Data sheet status	
Objective specification	This data sheet contains target or goal specifications for product development.
Preliminary specification	This data sheet contains preliminary data; supplementary data may be published later.
Product specification	This data sheet contains final product specifications.
Limiting values	
Limiting values given are in accordance with the Absolute Maximum Rating System (IEC 134). Stress above one or more of the limiting values may cause permanent damage to the device. These are stress ratings only and operation of the device at these or at any other conditions above those given in the Characteristics sections of the specification is not implied. Exposure to limiting values for extended periods may affect device reliability.	
Application information	
Where application information is given, it is advisory and does not form part of the specification.	

LIFE SUPPORT APPLICATIONS

These products are not designed for use in life support appliances, devices, or systems where malfunction of these products can reasonably be expected to result in personal injury. Philips customers using or selling these products for use in such applications do so at their own risk and agree to fully indemnify Philips for any damages resulting from such improper use or sale.