

# STK392-110

Thick Film Hybrid IC  
**3-Channel Convergence Correction Circuit**  
 (IC max = 3A)

## Overview

The STK392-110 is a convergence correction circuit IC for video projectors. It incorporates three output amplifiers in a single package, making possible the construction of CRT horizontal and vertical convergence correction output circuits for each of the RGB colors using just two hybrid ICs. The output circuit use a class-B configuration, in comparison with the STK392-010, realizing a more compact package and lower cost.

## Applications

- Video projectors

## Features

- 3 output amplifier circuits in a single package
- High maximum supply voltage ( $V_{CC}$  max =  $\pm 38V$ )
- Low thermal resistance ( $\theta_{j-c}=3.0^{\circ}C/W$ )
- High temperature stability ( $T_C$  max= $125^{\circ}C$ )
- Separate predriver and output stage supplies
- Output stage supply switching for high-performance designs
- Low inrush current when power is applied

## Series Organization

The following devices form a series with varying output capacity and application grade. Some of the devices below are under development, so contact your nearest sales representative for details.

Type No.	Maximum ratings			Maximum horizontal frequency $f_H$ max	Application grade
	$V_{CC}$ max	$I_C$ max	$\theta_{j-c}$		
STK392-110	$\pm 38V$	3A	$3.0^{\circ}C/W$	15kHz	General projection TVs
STK392-010	$\pm 38V$	5A	$2.6^{\circ}C/W$	15kHz	General projection TVs
STK392-020	$\pm 44V$	6A	$2.1^{\circ}C/W$	35kHz	HD, VGA
STK392-040	$\pm 50V$	7A	$1.8^{\circ}C/W$	100kHz	XGA, CAD, CAM
STK392-210	$\pm 65V$	8A	$1.5^{\circ}C/W$	130kHz	CAD, CAM
STK392-220	$\pm 75V$	10A	$1.3^{\circ}C/W$	160kHz	CAD, CAM

## Package Dimensions

unit:mm  
4083

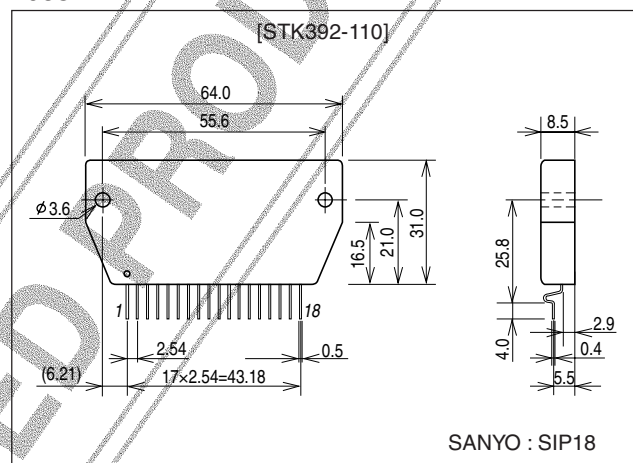

■ Any and all SANYO Semiconductor products described or contained herein do not have specifications that can handle applications that require extremely high levels of reliability, such as life-support systems, aircraft's control systems, or other applications whose failure can be reasonably expected to result in serious physical and/or material damage. Consult with your SANYO Semiconductor representative nearest you before using any SANYO Semiconductor products described or contained herein in such applications.

■ SANYO Semiconductor assumes no responsibility for equipment failures that result from using products at values that exceed, even momentarily, rated values (such as maximum ratings, operating condition ranges, or other parameters) listed in products specifications of any and all SANYO Semiconductor products described or contained herein.

**Specifications**

**Maximum Ratings** at Ta = 25°C

Parameter	Symbol	Conditions	Ratings	Unit
Maximum supply voltage	V <sub>CC</sub> max		±38	V
Maximum collector current	I <sub>C</sub>	Tr6, 7, 13, 14, 20, 21	3.0	A
Thermal resistance	θ j-c	Tr6, 7, 13, 14, 20, 21 (per transistor)	3.0	°C/W
Junction temperature	T <sub>J</sub>		150	°C
Operating temperature	T <sub>c</sub>		125	°C
Storage temperature	T <sub>stg</sub>		-30 to +125	°C

**Operating Characteristics** at Ta = 25°C, R<sub>g</sub>=50Ω, V<sub>CC</sub>=±30V, specified test circuit

Parameter	Symbol	Conditions	Ratings			Unit
			min	typ	max	
Output noise voltage	V <sub>NO</sub>				0.2	mVrms
Quiescent current	I <sub>CCO</sub>		15	22	30	mA
Neutral voltage	V <sub>N</sub>		-50	0	+50	mV
Output delay time	t <sub>D</sub>	f=15.75kHz, triangular wave input, V <sub>OUT</sub> =1.5Vp-p			1	μs

Note :

All tests are conducted using a constant-voltage regulated supply unless otherwise specified.  
The output noise voltage is the peak value of an average-reading meter with an rms value scale (VTVM).

**Block Diagram**

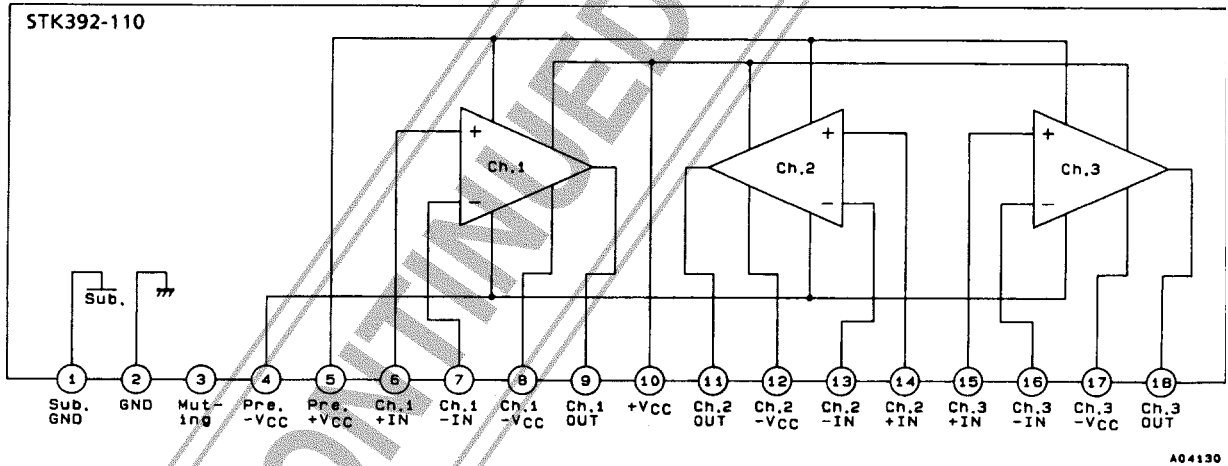

A04130

# STK392-110

## Equivalent Circuit

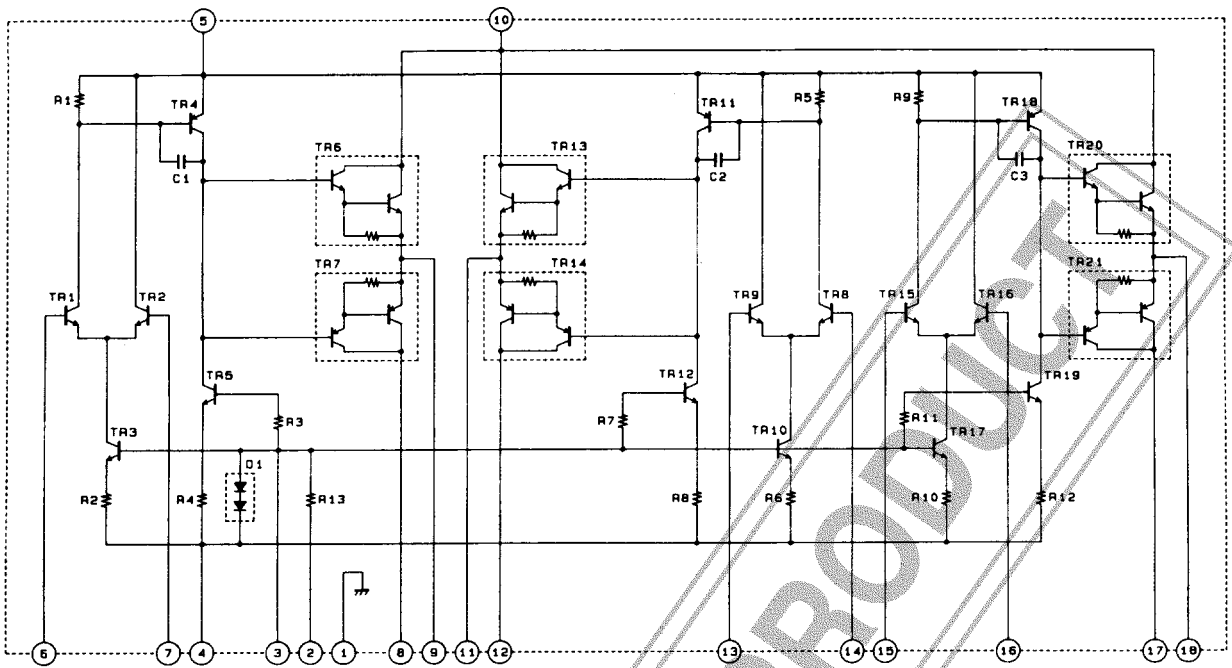

A04131

## Test Circuit

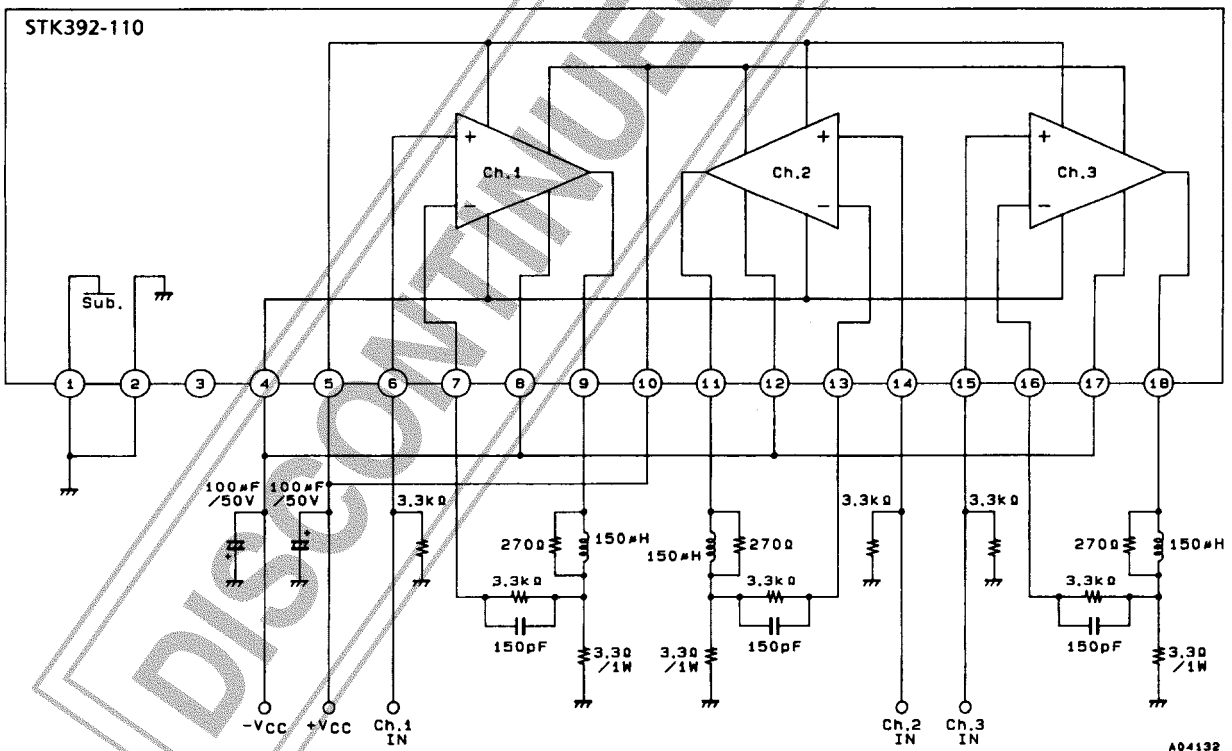

A04132

Sample Application Circuit

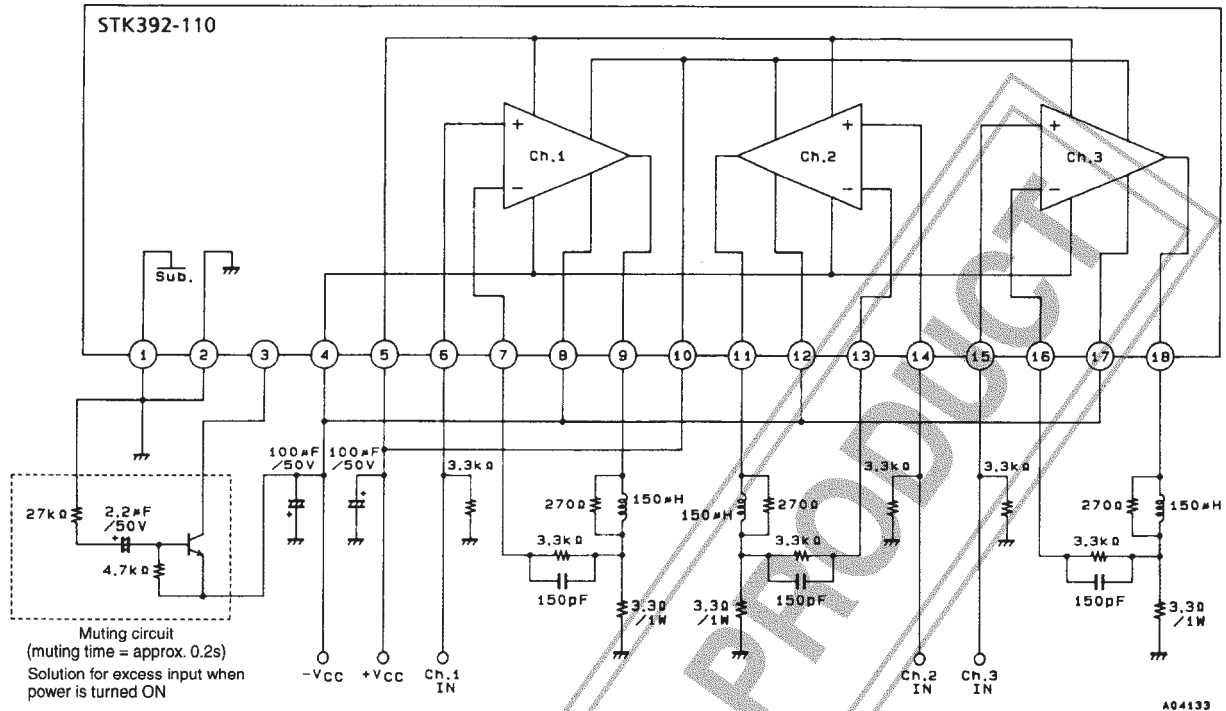

- Specifications of any and all SANYO Semiconductor products described or contained herein stipulate the performance, characteristics, and functions of the described products in the independent state, and are not guarantees of the performance, characteristics, and functions of the described products as mounted in the customer's products or equipment. To verify symptoms and states that cannot be evaluated in an independent device, the customer should always evaluate and test devices mounted in the customer's products or equipment.
- SANYO Semiconductor Co., Ltd. strives to supply high-quality high-reliability products. However, any and all semiconductor products fail with some probability. It is possible that these probabilistic failures could give rise to accidents or events that could endanger human lives, that could give rise to smoke or fire, or that could cause damage to other property. When designing equipment, adopt safety measures so that these kinds of accidents or events cannot occur. Such measures include but are not limited to protective circuits and error prevention circuits for safe design, redundant design, and structural design.
- In the event that any or all SANYO Semiconductor products (including technical data, services) described or contained herein are controlled under any of applicable local export control laws and regulations, such products must not be exported without obtaining the export license from the authorities concerned in accordance with the above law.
- No part of this publication may be reproduced or transmitted in any form or by any means, electronic or mechanical, including photocopying and recording, or any information storage or retrieval system, or otherwise, without the prior written permission of SANYO Semiconductor Co., Ltd.
- Any and all information described or contained herein are subject to change without notice due to product/technology improvement, etc. When designing equipment, refer to the "Delivery Specification" for the SANYO Semiconductor product that you intend to use.
- Information (including circuit diagrams and circuit parameters) herein is for example only; it is not guaranteed for volume production. SANYO Semiconductor believes information herein is accurate and reliable, but no guarantees are made or implied regarding its use or any infringements of intellectual property rights or other rights of third parties.

This catalog provides information as of September, 1999. Specifications and information herein are subject to change without notice.