

# BIPOLAR ANALOG INTEGRATED CIRCUIT

# $\mu$ PC1363C

## ELECTRONIC CHANNEL SELECTOR

### DESCRIPTION

The  $\mu$ PC1363C is an electronic channel selector integrated circuit. It is capable of selecting up to 16 channels. The output terminals are design to permit the direct driving of LED lamps or neon tubes.

This IC consists of Clock Oscillator circuit, Channel Up and Down circuit, Channel skip circuit, 4 bit Up and Down Counter circuit, 1-16 Decoder circuit and 16 channel Output Buffer circuit, all of which are contained in a 24 pins dual in-line package.

### FEATURES

- LED direct drive.  
1k=15mA,  $V_{KSAT}$  150mV MAX.
- Low power consumption.  
 $V_{CC}=12V$ ,  $I_{CC}=15mA$  TYP.
- Up to 16 channel selection.
- Internal schmitt trigger circuit. (CHU, CHD INPUT)
- Power ON initial channel set.
- $\mu$ PC1360C pin compatible. ( $V_{CC}=6V$ )
- TV, Radio etc. channel selection use.
- Using with  $\mu$ PD1986C (TX),  $\mu$ PD1937C (RX),  
direct address remote control system is realized.

### PACKAGE DIMENSIONS in millimeters (inches)

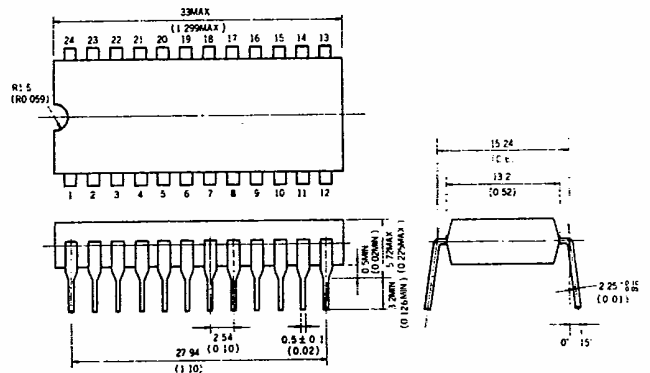

### BLOCK DIAGRAM

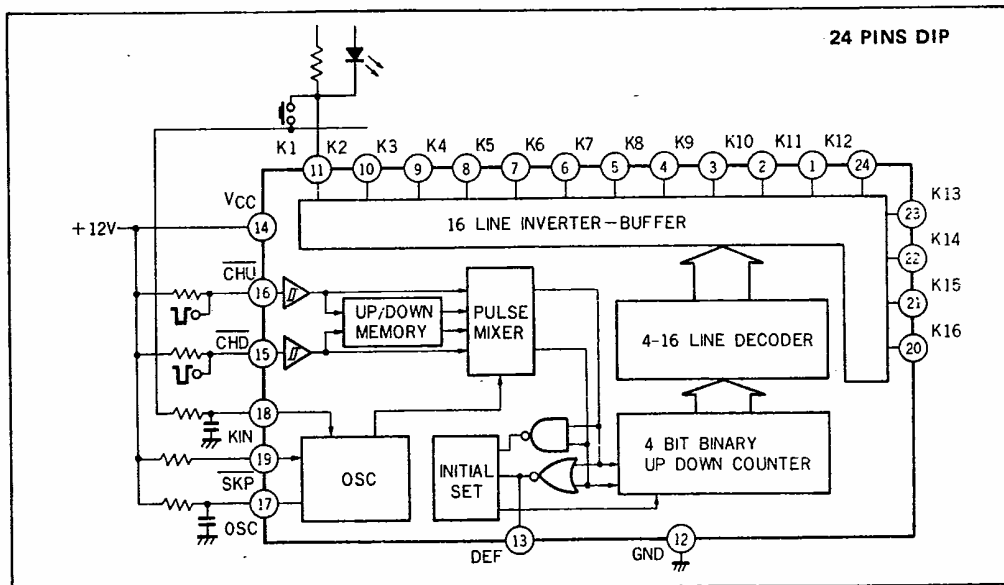

**ABSOLUTE MAXIMUM RATINGS (Ta=25°C)**

Supply Voltage	V <sub>CC</sub>	15.0	V
Input Current to Channel Selection Circuit	I <sub>K1~11, 20~24</sub>	-5 to 50	mA
Input Current to Control Circuit	I <sub>C15~19</sub>	-5 to 10	mA
Input Current to Control Circuit	I <sub>C13</sub>	-5 to 20	mA
* Output Voltage to Channel Selection Circuit	V <sub>K1~11, 20~24</sub>	-0.5 to 50	V
* Output Voltage to Control Circuit	V <sub>13</sub>	-0.5 to 14.4	V
* Input Voltage to Control Circuit	V <sub>17</sub>	-0.5 to V <sub>CC</sub>	V
Power Dissipation	P <sub>d</sub>	350	mW
Operating Temperature Range	T <sub>opt</sub>	-20 to +75	°C
Storage Temperature Range	T <sub>stg</sub>	-40 to +125	°C

\* At V<sub>CC</sub> = 12V

**RECOMMENDED OPERATING CONDITIONS**

CHARACTERISTIC	SYMBOL	MIN.	TYP.	MAX.	UNIT
Supply Voltage	V <sub>CC</sub>	9.6	12.0	14.4	V
Channel Selection Input Current	I <sub>K</sub>		15.0		mA
Clock Oscillation Frequency	f <sub>OSC</sub>		2.0	10.0	kHz

**ELECTRICAL CHARACTERISTICS (Ta=25 ±3°C)**

CHARACTERISTIC	SYMBOL	MIN.	TYP.	MAX.	UNIT	TEST CONDITIONS
Supply Current	I <sub>DD</sub>	7.0	15.0	22.0	mA	V <sub>CC</sub> =12V
Channel Selection Saturation Voltage	V <sub>OL(K)</sub>			150	mV	V <sub>CC</sub> =9.6V, I <sub>OL</sub> =15mA
Channel Selection Leakage Current	I <sub>OH(K)</sub>			10	μA	V <sub>CC</sub> =14.4V, V <sub>OH</sub> =35V
AFT Defeat Output Voltage	V <sub>OL(D)</sub>			6	V	V <sub>CC</sub> =9.6V, I <sub>OL</sub> =12mA
AFT Defeat Leakage Current	I <sub>OH(D)</sub>			10	μA	V <sub>CC</sub> =14.4V, V <sub>OH</sub> =14.4V
Channel Input High Threshold Voltage	V <sub>TH(CH)</sub>	3.5		7.0	V	V <sub>CC</sub> =12V, R <sub>i</sub> =15kΩ
Channel Input Low Threshold Voltage	V <sub>TL(CH)</sub>	1.5		2.5	V	V <sub>CC</sub> =12V, R <sub>i</sub> =15kΩ
Channel Input Leakage Current	I <sub>CH(CH)</sub>	-5			μA	V <sub>CC</sub> =14.4V, V <sub>IL</sub> =0V
Key Input Current	I <sub>IH(KI)</sub>	200			μA	V <sub>CC</sub> =9.6V
Key Input Leakage Current	I <sub>IL(KI)</sub>	-10			μA	V <sub>CC</sub> =14.4V, V <sub>IL</sub> =0V
Skip Input Current	I <sub>IH(SK)</sub>	50			μA	V <sub>CC</sub> =9.6V
Skip Input Leakage Current	I <sub>IL(SK)</sub>	-5			μA	V <sub>CC</sub> =14.4V, V <sub>IL</sub> =0V
OSC Input Current	I <sub>IH(OSC)</sub>	1.5		3.0	mA	V <sub>CC</sub> =9.6V, V <sub>IH</sub> =4V
OSC Leakage Current	I <sub>IL(OSC)</sub>			10	μA	V <sub>CC</sub> =14.4V, V <sub>IL</sub> =1.0V
OSC Frequency	f <sub>OSC</sub>	1.5		2.5	kHz	V <sub>CC</sub> =12V, R=68kΩ, C=0.022μF

# EQUIVALENT CIRCUIT

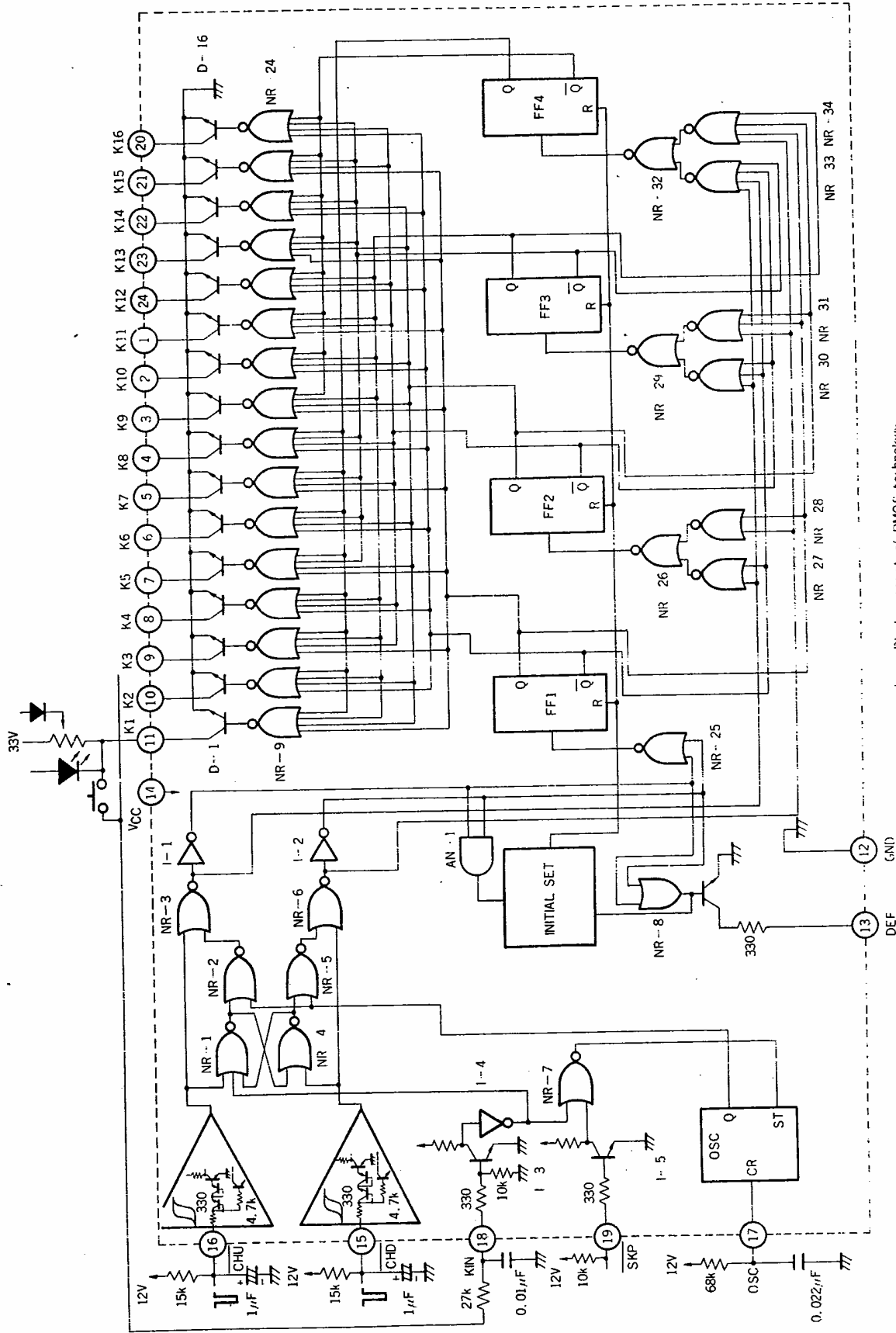

Logic Blocks consist of PMOS technology  
 Output, Input, and OSC. consist of Bipolar technology

### CONNECTION DIAGRAM (Top View)

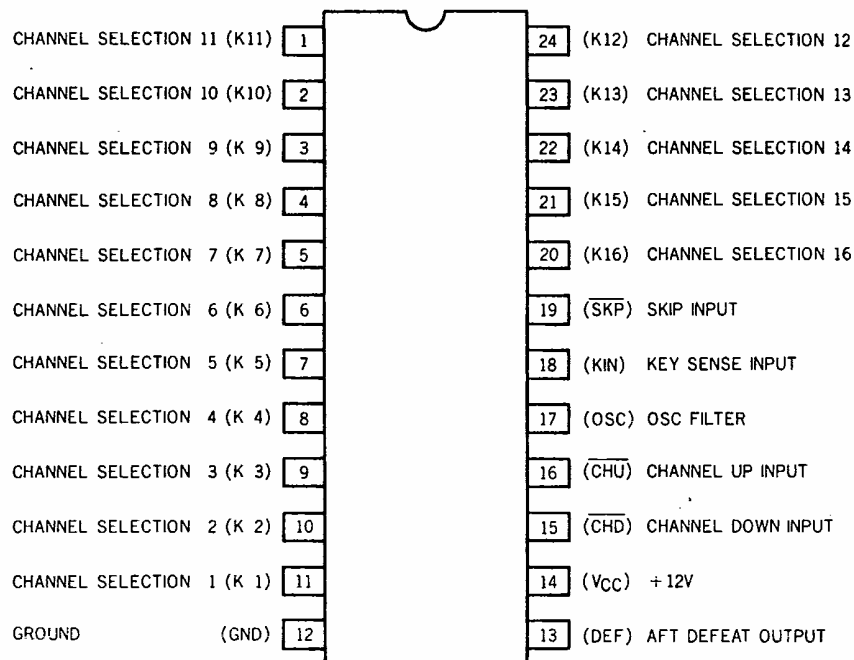

### PIN FUNCTION

**K1 ~ 16 (#11 ~ 1, #24 ~ 20) CHANNEL SELECTION OUTPUT**

These are the output terminals constructed of collector-opened transistors, so they can drive potentiometers and indicators, and key output. They have saturation voltage of 150mV at  $I_K = 15mA$ , so they can drive LEDs directly.

**GND (#12) GROUND**

**DEF (#13) AFT DEFEAT OUTPUT**

This terminal is made of open collector transistor output through a resistor of  $330\Omega$ . It is used for AFT (Automatic Fine Tuning……TV use) defeat, sound muting and LED indicate erasing.

**V<sub>CC</sub> (#14) +12V (9.6 ~ 12V)**

**CHD (#15) CHANNEL DOWN INPUT**

Usually pulled up to  $V_{CC}$  through a resistor, Channel selector changes at positive going edge of input signal of this terminal and the channel selector works orderly from K16 to K1.

**CHU (#16) CHANNEL UP INPUT**

Usually pull up to  $V_{CC}$  through a resistor, Channel selector changes at positive going edge of input signal of this terminal and the channel selector works orderly from K1 to K16. If CHU and CHD terminals put down to ground at same time, initial channel is selected. So, it is very useful to power on channel set or remote control operation use.

These terminals include schmitt trigger circuit and this hysteresis level is controlled by external resistors.

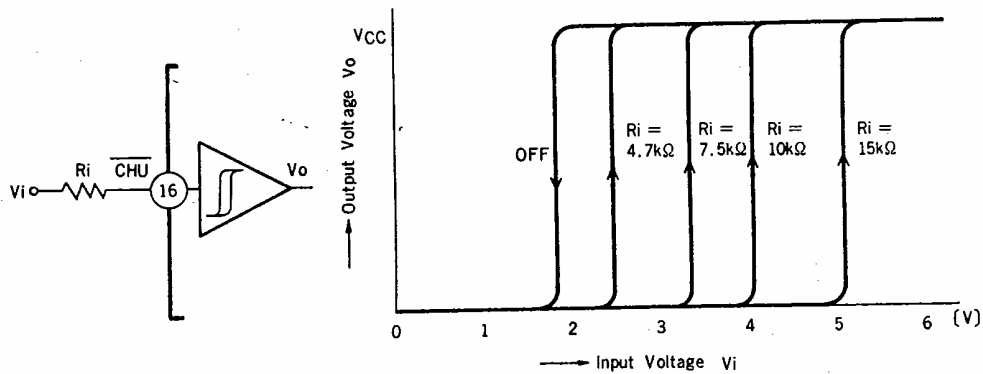

CHU, CHD Input Schmitt Characteristic

OSC ( #17 ) OSC FILTER

When a Channel key is pushed or skip function is operated, oscillator contained in this IC oscillate with C, R connected to this terminal. Typical oscillation frequency is 2kHz. (R = 68k, C = 0.022 $\mu$ F)

KIN ( #18 ) KEY INPUT

When channel selection key is pushed, as pushed channel is not selected, "High" level of signal is applied to this terminal through a potentiometer. Then channel selector scans terminals of K1 ~ K16. And when sense up this terminal, it pull down the voltage of this terminal and stop the scanning.

SKP ( #19 ) SKIP INPUT

Usually pull up to  $V_{CC}$  through resistor. When only 12 channels are used, connect terminals (K13 ~ K16) to this terminal.

## CHARACTERISTICS

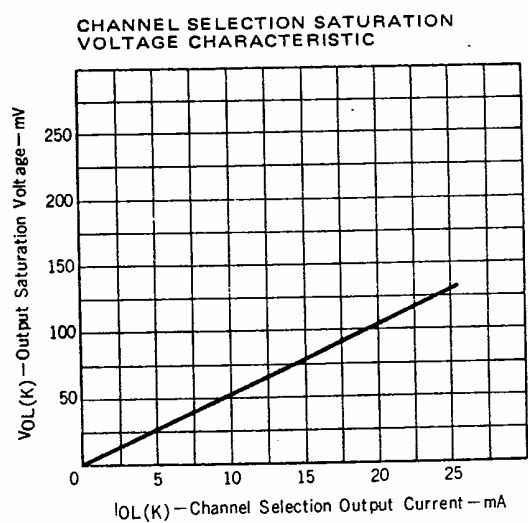
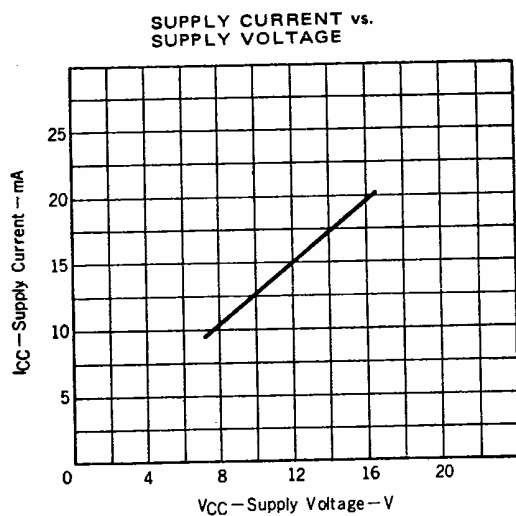

## INITIAL CHANNEL SET and REMOTE CONTROL CIRCUIT

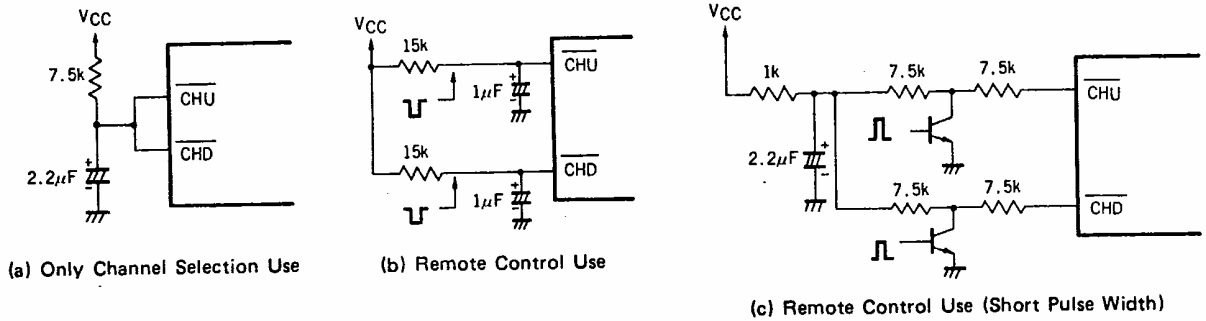

## APPLICATION CIRCUIT 1

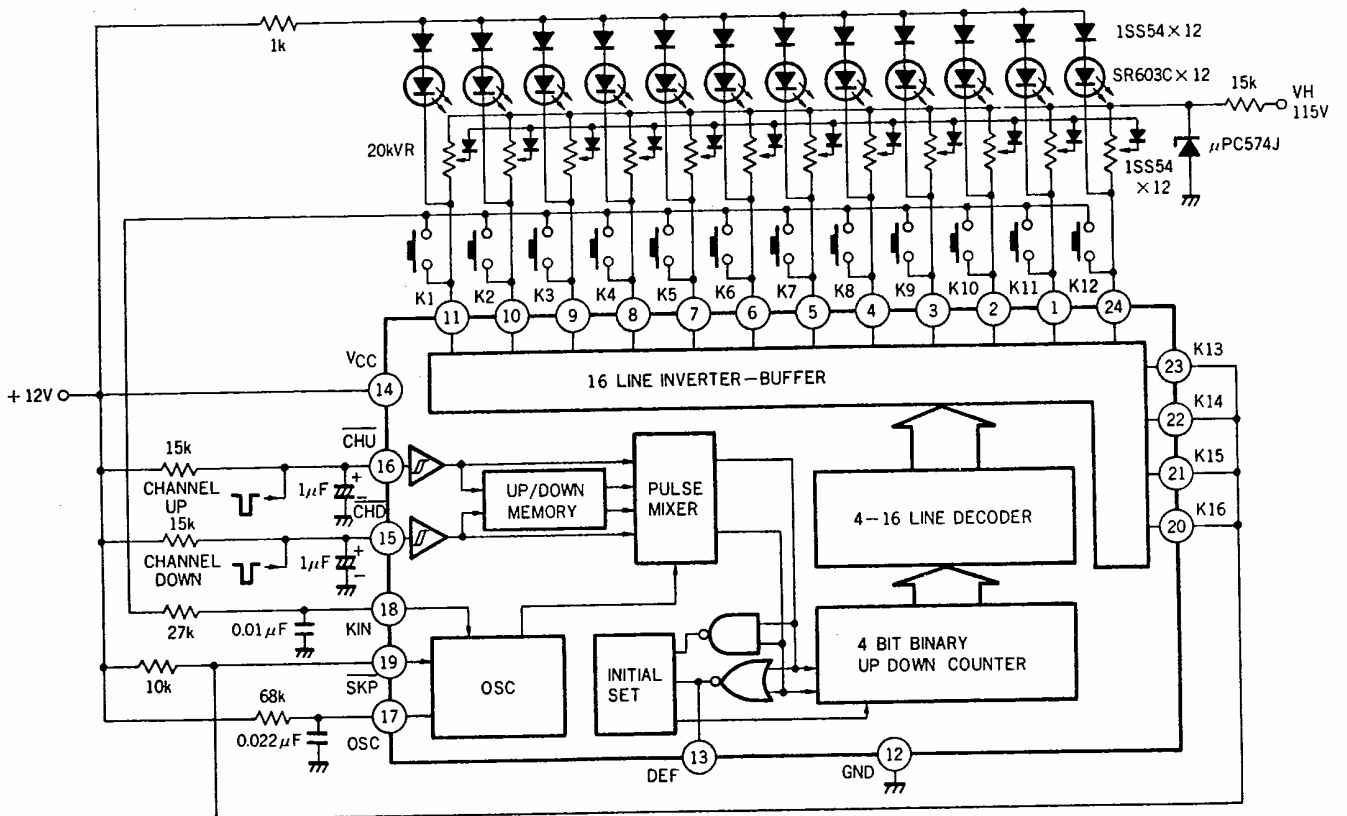

# APPLICATION CIRCUIT 2

## EXAMPLE OF TV CHANNEL SELECTION

### 12 POSITION SELECTION CIRCUIT (4 POSITION IS SKIPPED)

