

LC7533 — CMOS IC

3V Electronic Volume Control

Use

- Attenuation of signal.

Features

- CMOS process 3V typ. operation.
 - Up/down operation is performed with SW input.
 - 4-bit, 16-step counter. Step 6* is set with initial input(INIT).
 - Center tap provided.
 - Maximum attenuation : -60dB or less.
 - Attenuation curve : Pseudo curve A. Left/right simultaneous setting.
- * : Step 6 means mode 6.

Package Dimensions

(unit:mm)

3006C-DIP16

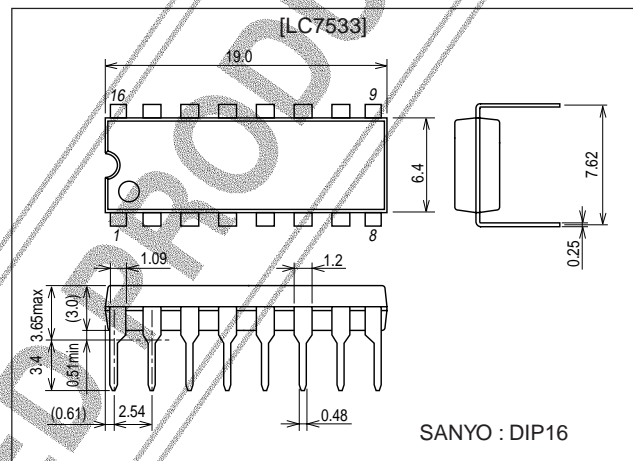

Specifications

Absolute Maximum Ratings at Ta = 25°C

Parameter	Symbol	Conditions	Ratings	Unit
Maximum supply voltage	V _{DD max}		V _{SS} to 6	V
Supply voltage	V _I		V _{SS} to V _{DD}	V
Allowable power dissipation	P _{d max}		100	mW
Operating temperature	T _{opr}		-30 to +75	°C
Storage temperature	T _{stg}		-40 to +125	°C

Allowable Operating Conditions at Ta = 25°C

Parameter	Symbol	Conditions	Ratings	Unit
Supply voltage	V _{DD}		2.1 to 5.0	V
Input high-level voltage	V _{IH1}	INIT, CE pin	0.7V _{DD} to V _{DD}	V
	V _{IH2}	UP, DN, CR pin	0.9V _{DD} to V _{DD}	V
Input low-level voltage	V _{IL1}	INIT, CE	0 to 0.3V _{DD}	V
	V _{IL2}	UP, DN, CR	V _{SS} to 0.1V _{DD}	V

■ Any and all SANYO Semiconductor products described or contained herein do not have specifications that can handle applications that require extremely high levels of reliability, such as life-support systems, aircraft's control systems, or other applications whose failure can be reasonably expected to result in serious physical and/or material damage. Consult with your SANYO Semiconductor representative nearest you before using any SANYO Semiconductor products described or contained herein in such applications.

■ SANYO Semiconductor assumes no responsibility for equipment failures that result from using products at values that exceed, even momentarily, rated values (such as maximum ratings, operating condition ranges, or other parameters) listed in products specifications of any and all SANYO Semiconductor products described or contained herein.

LC7533

Electrical Characteristics at Ta = 25°C

Parameter	Symbol	Conditions	Ratings			Unit
			min	typ	max	
Signal distortion	THD ₁	V _{DD} =3V, R _L =50kΩ, f=1kHz			0.5	%
	THD ₂	V _{DD} =2.1V, R _L =50kΩ, f=1kHz		1		%
Output at attenuation mode	X _{OUT}	0dBm input, 1kHz, 51kΩ load			-60	dB
Signal transmit delay time	t _d	Between IN and OUT, no load		1		μs
Input impedance	r _i	UP, DN, CE only	100		400	kΩ
Output noise voltage	V _{NO}	V _{DD} =3V, R _L =50kΩ, STEP" 0"			8	μV
Input high-level current	I _{IH}	CE pin, V _{DD} =3V, V _I =3V			40	μA
Input low-level current	I _{IL}	UP, DN pin, V _{DD} =3V, V _I =0V	-55			μA
Attenuation balance	ΔV	Pins OUT1, 2, other than STEP" 0" (Note1)	-2	0	+2	dB
Channel balance	ΔV _O	Between pins OUT1, 2, other than STEP" 0" (Note2)	-2		+2	dB
Current drain	I _{DD}	V _{DD} =3V, CE=V _{DD} , INIT=V _{DD} , other pins:OPEN			1	mA
	I _{DD} BACK UP	V _{DD} =3V, CE=V _{SS} , INIT=V _{DD} , other pins:OPEN			1	μA
Crosstalk between channels	CT	V _{DD} =1.5V, V _{SS} =-1.5V, V _M =0V, f=1kHz, 1Vrms input, test side input : 1kΩ short		85		dB
Minimum pulse width	T _{UP/DN}	T=(CR oscillation cycle) UP, DN pin		1.5T		ms
	T _{INIT}	INIT pin	2			μs

Note 1 (1) $\Delta V = 20 \log_{10} V_{OUT} / V_{TYP}$

V_{OUT} : OUT1(OUT2) output level

V_{TYP} : Standard output level

(2) Satisfy V_{OUT}(STEP N) < V_{OUT}(STEP N + 1)

Note 2 (1) $\Delta V_O = 20 \log_{10} V_{OUT1} / V_{OUT2}$

Pin Assignment

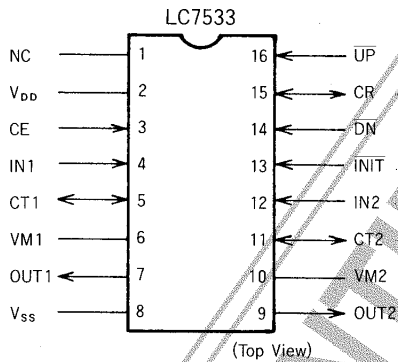

Note 1 : No bonding exists on the inside of NC pin. It is recommended that the outside should be shorted to V_{DD}, V_{SS}, etc. on the printed circuit board.

Pin Description

Pin Name	Pin Number	Description
IN1, IN2	4, 12	Input pin for volume control
OUT1, OUT2	7, 9	Output pin for volume control
V _{M1} , V _{M2}	6, 10	Bias pin. When operated from single supply, 1/2V _{DD} is applied to this pin.
C _{T1} , C _{T2}	5, 11	Tap pin provided at the center of volume control. By connecting C and R to this pin, the loudness can be controlled.
CE	3	When this pin is set to "L", the current drain is reduced. This pin must be "L" at backup mode.
INIT	13	Initial pin. When set to "L", the 6th step is reached.
UP	16	When the level on this pin is made to fall, the step rises and the volume goes up. When held at "L", the volume goes up; if set to "H", the volume stops going up at a step reached at that moment. The step stops at the MSB position.
DN	14	The DN operation is the reverse of UP. when the UP, DN are set to "L" at the same time, the UP is given priority. The step stops at the LSB position.
CR	15	Pin for connecting R, C on which the rate of step depends.
V _{DD}	2	Power supply pin (+)
V _{SS}	8	Ground
NC	1	No bonding exists on the inside of NC pin. Connected to V _{DD} or V _{SS} is recommended.

Equivalent Circuit Block Diagram

[Common to LC7533]

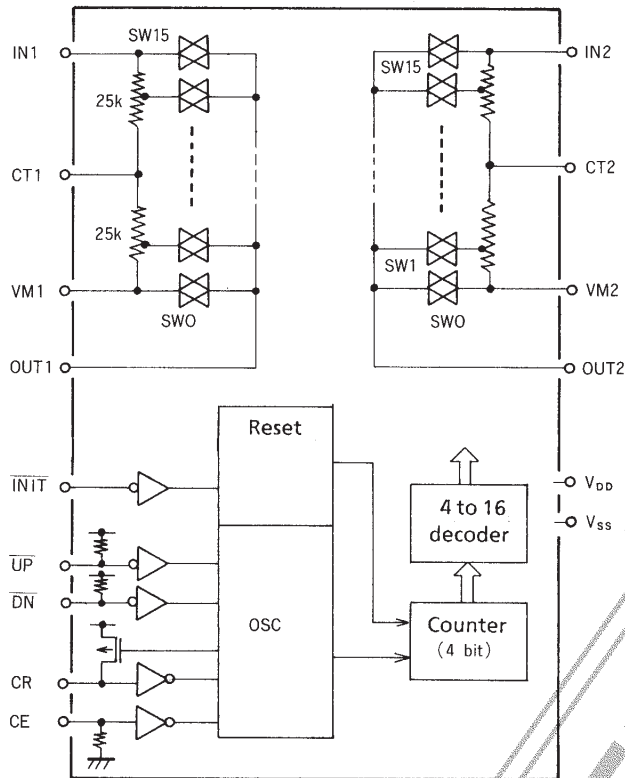

Note 1 : The TEST pin is bonded only when the MFP20 is used.

Sample Application Circuit

[LC7533 DIP16]

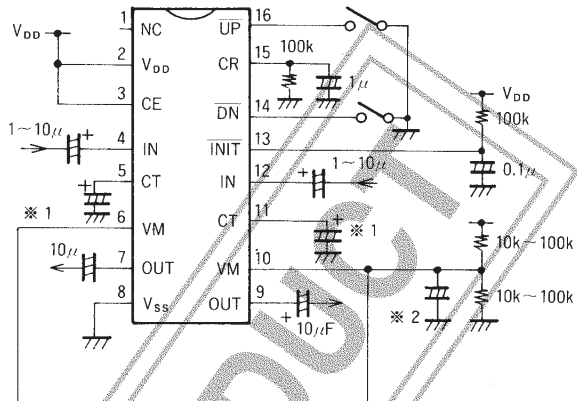

For V_M , $1/2V_{DD}$ bias is recommended.
 ※1 For low-band boost (approx. $1\mu F$)
 ※2 The larger the capacity is (approx. $100\mu F$), the better the characteristics of attenuation and crosstalk.

Unit (resistance: Ω , capacitance: F)

- Specifications of any and all SANYO Semiconductor products described or contained herein stipulate the performance, characteristics, and functions of the described products in the independent state, and are not guarantees of the performance, characteristics, and functions of the described products as mounted in the customer's products or equipment. To verify symptoms and states that cannot be evaluated in an independent device, the customer should always evaluate and test devices mounted in the customer's products or equipment.
- SANYO Semiconductor Co., Ltd. strives to supply high-quality high-reliability products. However, any and all semiconductor products fail with some probability. It is possible that these probabilistic failures could give rise to accidents or events that could endanger human lives, that could give rise to smoke or fire, or that could cause damage to other property. When designing equipment, adopt safety measures so that these kinds of accidents or events cannot occur. Such measures include but are not limited to protective circuits and error prevention circuits for safe design, redundant design, and structural design.
- In the event that any or all SANYO Semiconductor products (including technical data, services) described or contained herein are controlled under any of applicable local export control laws and regulations, such products must not be exported without obtaining the export license from the authorities concerned in accordance with the above law.
- No part of this publication may be reproduced or transmitted in any form or by any means, electronic or mechanical, including photocopying and recording, or any information storage or retrieval system, or otherwise, without the prior written permission of SANYO Semiconductor Co., Ltd.
- Any and all information described or contained herein are subject to change without notice due to product/technology improvement, etc. When designing equipment, refer to the "Delivery Specification" for the SANYO Semiconductor product that you intend to use.
- Information (including circuit diagrams and circuit parameters) herein is for example only; it is not guaranteed for volume production. SANYO Semiconductor believes information herein is accurate and reliable, but no guarantees are made or implied regarding its use or any infringements of intellectual property rights or other rights of third parties.

This catalog provides information as of May, 2001. Specifications and information herein are subject to change without notice.