

Silicon NPN Power Transistor

BU2522DF

DESCRIPTION

- High Switching Speed
- High Voltage
- Built-in Ddamper Ddiode

APPLICATIONS

- Designed for use in horizontal deflection circuits of high resolution monitors.

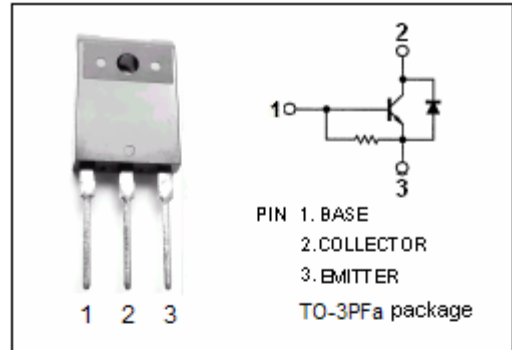

ABSOLUTE MAXIMUM RATINGS (T_a=25)

SYMBOL	PARAMETER	VALUE	UNIT
V _{CBO}	Collector-Base Voltage	1200	V
V _{CEO}	Collector-Emitter Voltage	800	V
V _{EBO}	Emitter-Base Voltage	7.5	V
I _C	Collector Current-Continuous	10	A
I _{CM}	Collector Current-peak	25	A
I _B	Base Current-Continuous	6	A
I _{BM}	Base Current-peak	9	A
P _C	Collector Power Dissipation @T _C =25	45	W
T _j	Junction Temperature	150	
T _{stg}	Storage Temperature Range	-65~150	

THERMAL CHARACTERISTICS

SYMBOL	PARAMETER	MAX	UNIT
R _{th j-c}	Thermal Resistance, Junction to Case	2.8	K/W

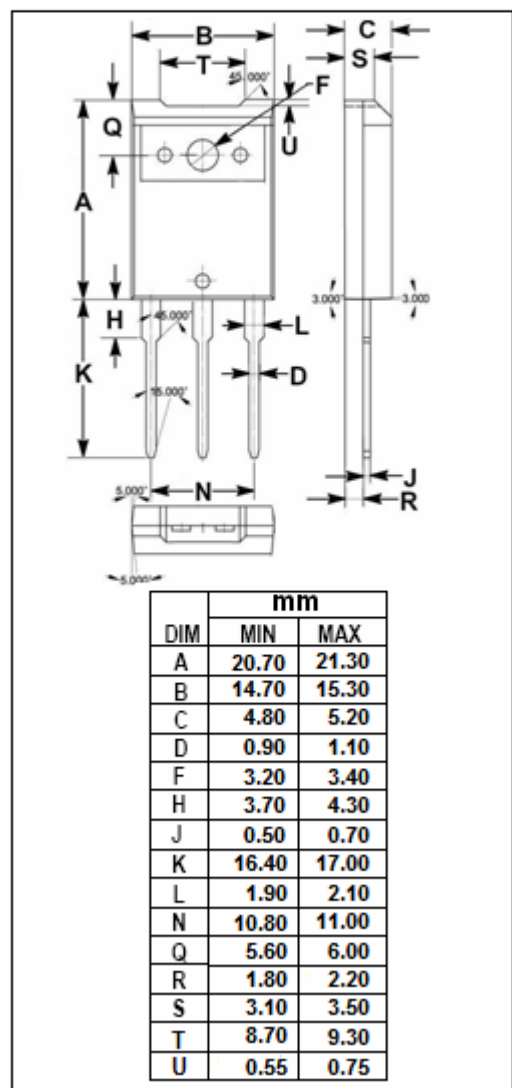

Silicon NPN Power Transistor

BU2522DF

ELECTRICAL CHARACTERISTICS

 $T_C=25$ unless otherwise specified

SYMBOL	PARAMETER	CONDITIONS	MIN	TYP.	MAX	UNIT
$V_{CEO(SUS)}$	Collector-Emitter Sustaining Voltage	$I_C= 100mA ; I_B= 0, L= 25mH$	800			V
$V_{(BR)EBO}$	Emitter-Base Breakdown Voltage	$I_E= 600mA ; I_C= 0$	7.5	13.5		V
$V_{CE(sat)}$	Collector-Emitter Saturation Voltage	$I_C= 6A ; I_B= 1.2A$			5.0	V
$V_{BE(sat)}$	Base-Emitter Saturation Voltage	$I_C= 6A ; I_B= 1.2A$			1.3	V
I_{CES}	Collector Cutoff Current	$V_{CE}= BV_{CES}; V_{BE}= 0$ $V_{CE}= BV_{CES}; V_{BE}= 0; T_C=125$			0.25 2.0	mA
I_{EBO}	Emitter Cutoff Current	$V_{EB}= 7.5V; I_C= 0$	100		300	mA
h_{FE-1}	DC Current Gain	$I_C= 1A ; V_{CE}= 5V$		10		
h_{FE-2}	DC Current Gain	$I_C= 6A ; V_{CE}= 5V$	5		8	
V_{ECF}	C-E Diode Forward Voltage	$I_F= 6A$			2.0	V
C_{OB}	Output Capacitance	$I_E= 0 ; V_{CB}= 10V; f_{test}= 1MHz$		115		pF