

MOTOR SPEED REGULATOR

- EXCELLENT VERSATILITY IN USE
- HIGH OUTPUT CURRENT (up to 1.5 A)
- LOW QUIESCENT CURRENT
- LOW REFERENCE VOLTAGE (1.32 V)
- EXCELLENT PARAMETERS STABILITY VERSUS AMBIENT TEMPERATURE
- START/STOP FUNCTION (TTL levels)
- DUMP PROTECTION

DESCRIPTION

The TDA7275A is a linear integrated circuit in mini-dip plastic package. It is intended for use as speed regulator for DC motors of record players, tape and cassette recorders.

The dump protection make it particularly suitable for car radio applications.

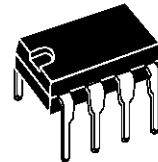

MINIDIP
(4 + 4)

ORDERING NUMBER : TDA7275A

PIN CONNECTION (top view)

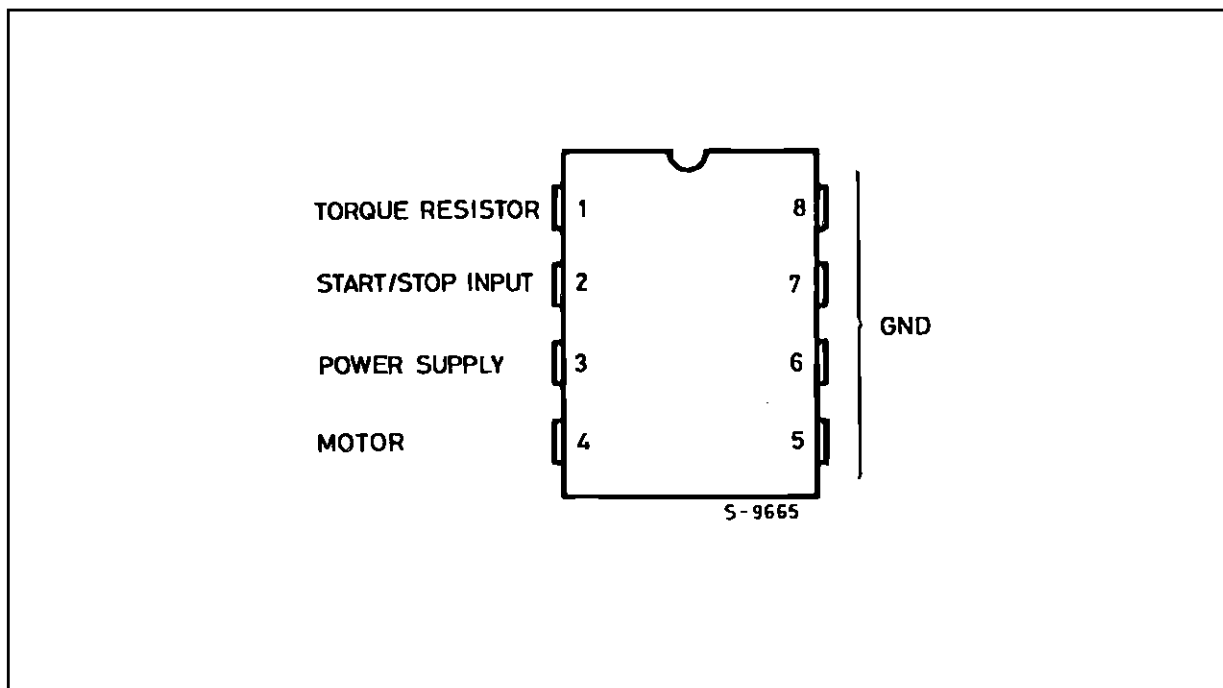

SCHEMATIC DIAGRAM

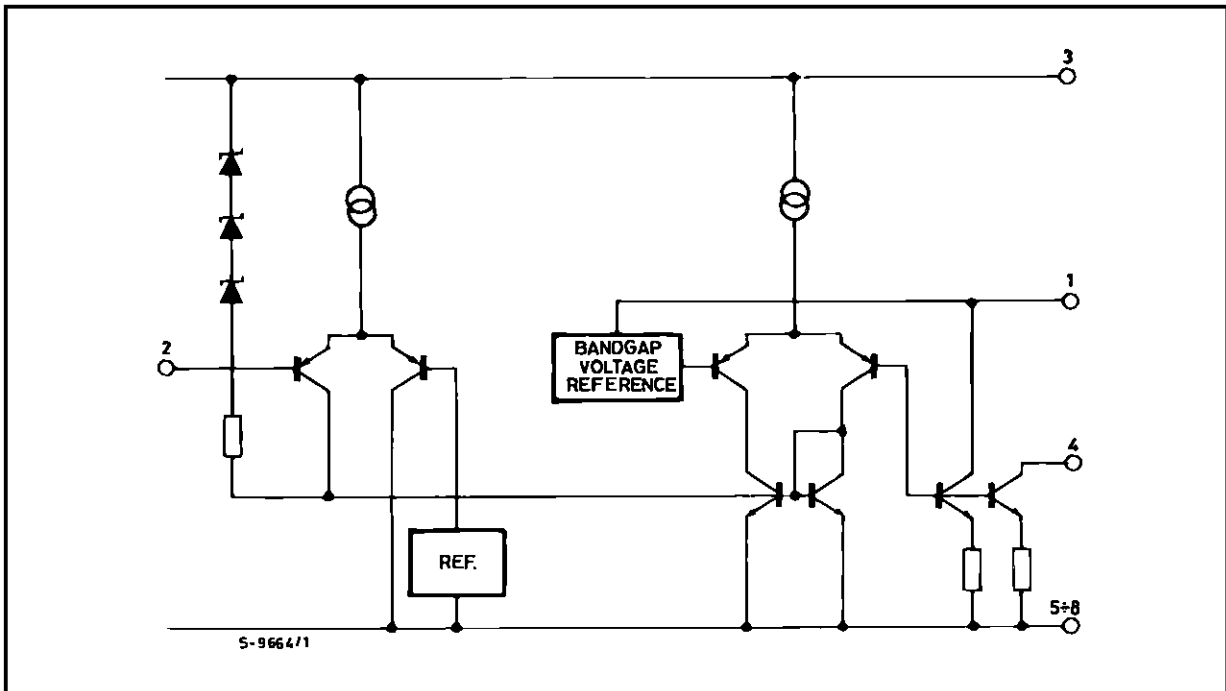

ABSOLUTE MAXIMUM RATINGS

Symbol	Parameter	Value	Unit
V_S	Supply Voltage	19	V
V_S	Peak Supply Voltage (for 50ms)	45	V
I_M	Maximum Output Current	1.5	A
T_{op}	Operating Temperature Range	-30 to +85	°C
P_{tot}	Power Dissipation at $T_{amb} = 70^\circ\text{C}$ at $T_{pins} = 70^\circ\text{C}$	1	W
		4	W

THERMAL DATA

Symbol	Parameter	Value	Unit
$R_{th\ j-amb}$	Thermal Resistance Junction-ambient	80	°C/W
$R_{th\ j-pins}$	Max. Thermal Resistance Junction -pins	20	°C/W
	Max.		

ELECTRICAL CHARACTERISTICS (Refer to test circuit, $V_S = 12V$, $T_{amb} = 25^\circ C$ unless otherwise specified, refer to test circuit)

Symbol	Parameter	Test Condition	Min.	Typ.	Max.	Unit
V_S	Supply Voltage Range		8		18	V
V_{ref}	Reference Voltage	$I_M = 0.1A$	1.05	1.22	1.35	V
$I_q + I_d$	Total Quiescent Current	$I_M = 0.1mA$		2		mA
I_d	Quiescent Current	$I_M = 0.1mA$		1		mA
I_{ms}	Starting Motor Current	$\frac{\Delta V_{ref}}{V_{ref}} = -50\%$	1			A
V_4	Saturation Voltage	$I_M = 0.5A$		1.7	2	V
$K = I_M/I_T$	Reflection coefficient	$I_M = 0.1A$	18	20	22	–
$\frac{\Delta K/\Delta V_S}{K}$		$I_M = 0.1A$ $V_S = 8 \text{ to } 16V$		0.5		%/V
$\frac{\Delta K/\Delta I_M}{K}$		$I_M = 25 \text{ to } 200mA$		-0.05		%/mA
$\frac{\Delta K/\Delta T}{K}$		$I_M = 0.1A$ $T_{op} = -30 \text{ to } +85^\circ C$		0.02		%/°C
$\frac{\Delta V_{ref}/\Delta V_S}{V_{ref}}$	Line Regulation	$I_M = 0.1A$ $V_S = 8 \text{ to } 16V$		0.04		%/V
$\frac{\Delta V_{ref}/\Delta I_M}{V_{ref}}$	Load Regulation	$I_M = 25 \text{ to } 200mA$		-0.01		%/mA
$\frac{\Delta V_{ref}/\Delta T}{V_{ref}}$	Temperature Coefficient	$I_M = 0.1A$ $T_{op} = -30 \text{ to } +85^\circ C$		0.02		%/°C
V_2	Motor "Stop" (Acc. Following data or grounded)			1		V
I_2	Motor "Stop"	$V_2 = 1V$		-0.05		mA
V_2	Motor "Run" (Acc. Following data or open)			1.5		V
I_2	Motor "Run"	$V_2 = 1.5V$		-0.1		mA

TDA7275A

Figure 1 : Test Circuit.

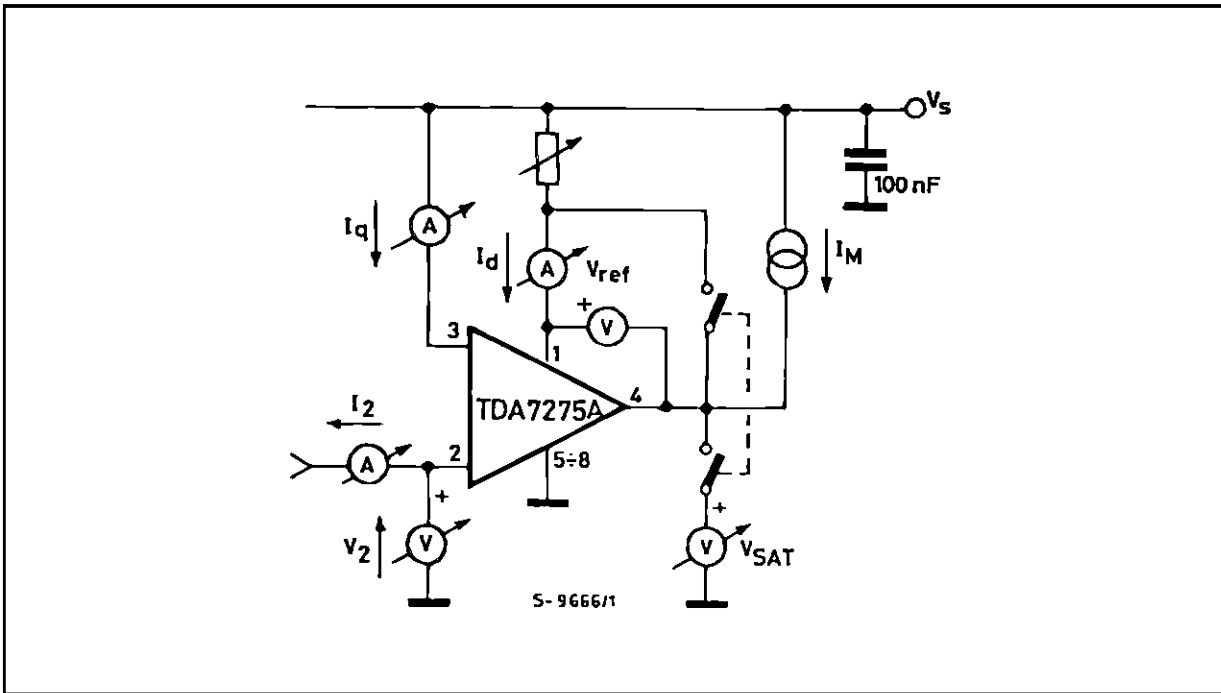
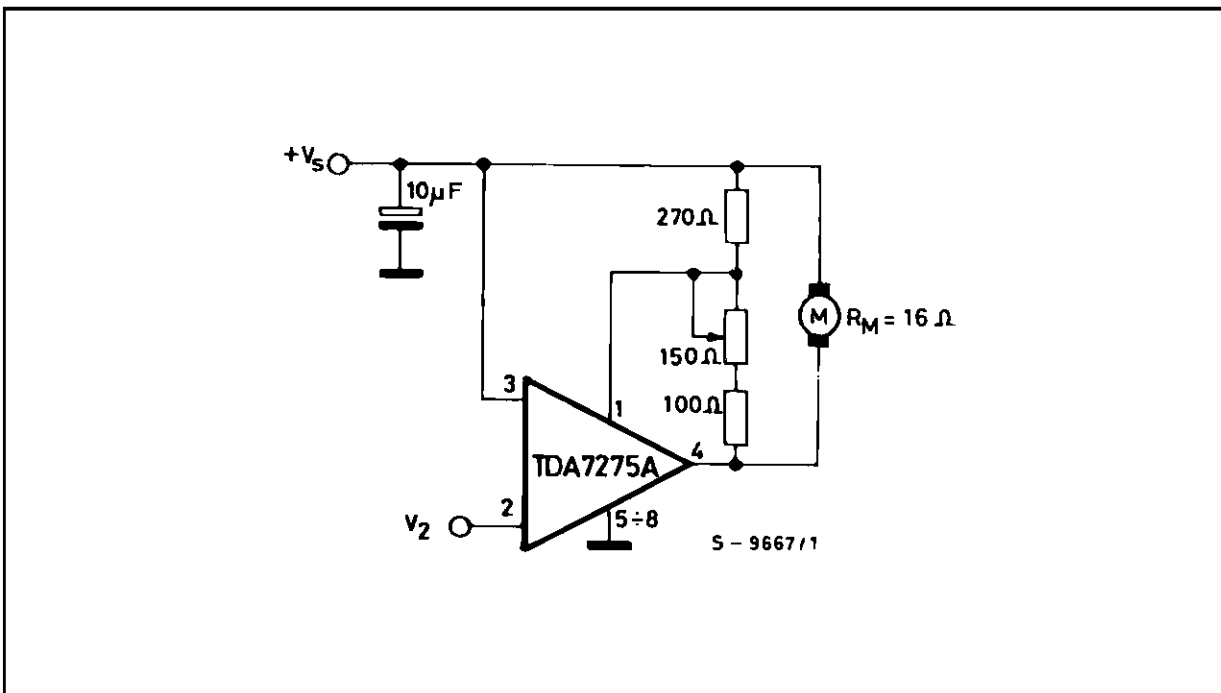

Figure 2 : Application Circuit.



- $R_{Ttyp.} = K_{typ.} R_{Mtyp.}$ if $R_T > K_{min} R_{Mmin}$ instability may occur.
- A diode across the motor could be necessary with certain kind of motor.

Figure 3 : Quiescent Current vs. Supply voltage.

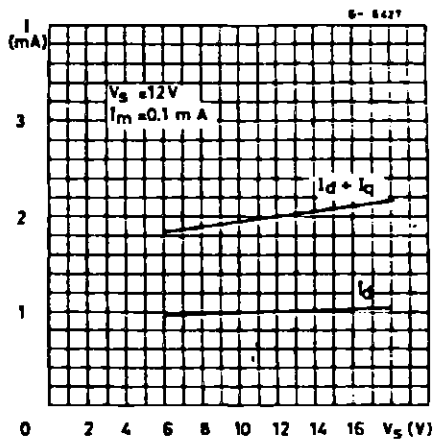

Figure 4 : Speed Variation vs. Supply Voltage.

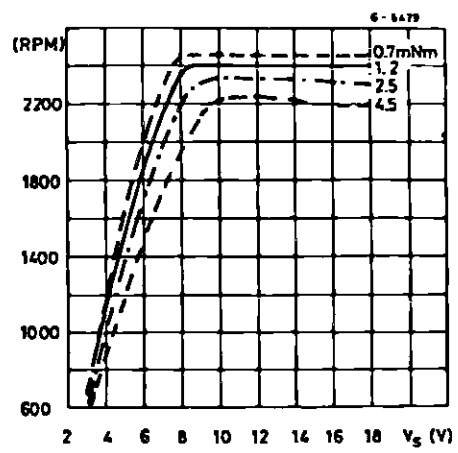
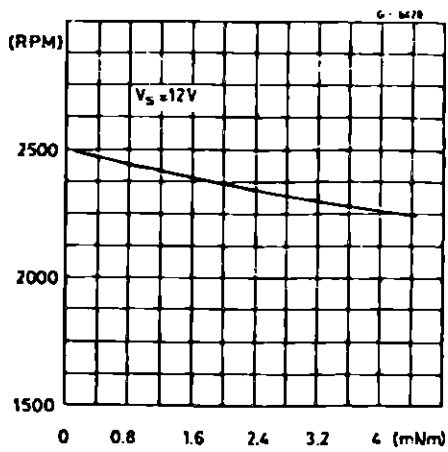
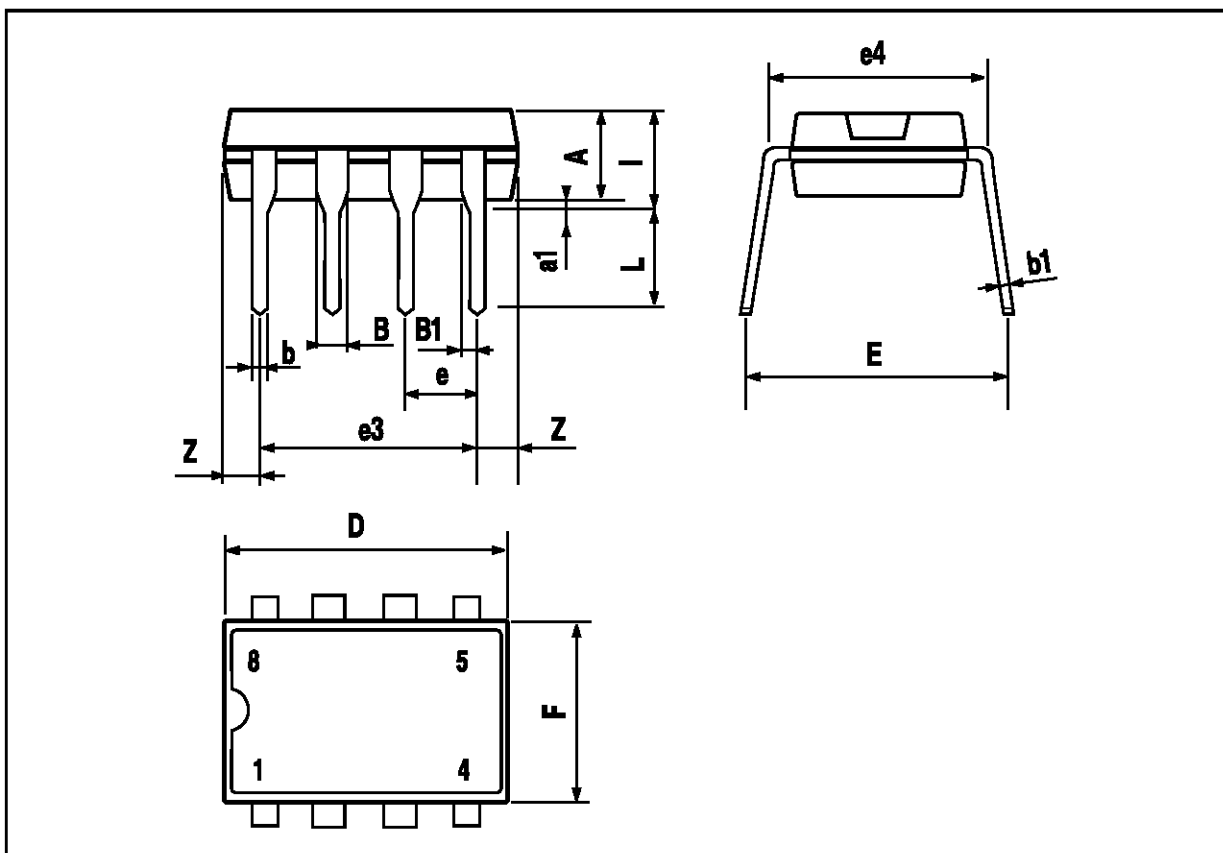

Figure 5 : Speed Variation vs. Torque ($V_S = 12V$).



MINIDIP PACKAGE MECHANICAL DATA

DIM.	mm			inch		
	MIN.	TYP.	MAX.	MIN.	TYP.	MAX.
A		3.3			0.130	
a1	0.7			0.028		
B	1.39		1.65	0.055		0.065
B1	0.91		1.04	0.036		0.041
b		0.5			0.020	
b1	0.38		0.5	0.015		0.020
D			9.8			0.386
E		8.8			0.346	
e		2.54			0.100	
e3		7.62			0.300	
e4		7.62			0.300	
F			7.1			0.280
I			4.8			0.189
L		3.3			0.130	
Z	0.44		1.6	0.017		0.063



Information furnished is believed to be accurate and reliable. However, SGS-THOMSON Microelectronics assumes no responsibility for the consequences of use of such information nor for any infringement of patents or other rights of third parties which may result from its use. No license is granted by implication or otherwise under any patent or patent rights of SGS-THOMSON Microelectronics. Specification mentioned in this publication are subject to change without notice. This publication supersedes and replaces all information previously supplied. SGS-THOMSON Microelectronics products are not authorized for use as critical components in life support devices or systems without express written approval of SGS-THOMSON Microelectronics.

© 1997 SGS-THOMSON Microelectronics – Printed in Italy – All Rights Reserved

SGS-THOMSON Microelectronics GROUP OF COMPANIES

Australia - Brazil - Canada - China - France - Germany - Hong Kong - Italy - Japan - Korea - Malaysia - Malta - Morocco -
The Netherlands - Singapore - Spain - Sweden - Switzerland - Taiwan - Thailand - United Kingdom - U.S.A.