

## TV-SAT-PLL with I<sup>2</sup>C-Bus and Four Chip Addresses

**SDA 6102X**

### Preliminary Data

**Bipolar IC**

#### Features

- 1-chip system for MPU control (I<sup>2</sup>C-bus)
- 4 programmable chip addresses
- Short pull-in time for quick channel switch-over and optimized loop stability
- 5 high-current switch outputs (20 mA)
- Software-compatible with SDA 3302 series
- Oxis III-technology

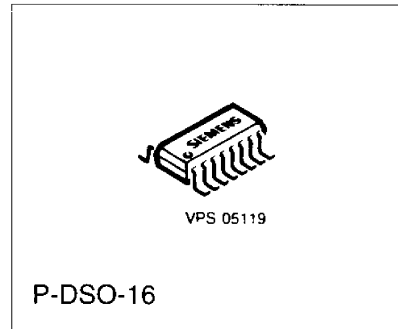

Type	Ordering Code	Package
SDA 6102X	Q67000-A5016	P-DSO-16 (SMD)

Combined with a VCO (tuner), the SDA 6102X device, with for hard-switched chip addresses, forms a digitally programmable phase-locked loop for use in satellite indoor units. It is compatible with the standard SDA 3202-2 device used in television sets with frequency synthesis tuning. With a 4.43-MHz quartz crystal, the PLL permits precise setting of the frequency of the tuner oscillator up to 2.27 GHz in increments of 69.2 kHz. Higher frequencies (up to 2.4 GHz) are possible at the expense of coarser frequency resolution. The tuning process is controlled by a microprocessor via an I<sup>2</sup>C-bus. The I<sup>2</sup>C-bus noise immunity has been improved by a factor of 10 compared to the SDA 3302-2, and the new crystal oscillator generates a sinusoidal signal, suppressing the higher-order harmonics, which reduces the moire noise considerably.

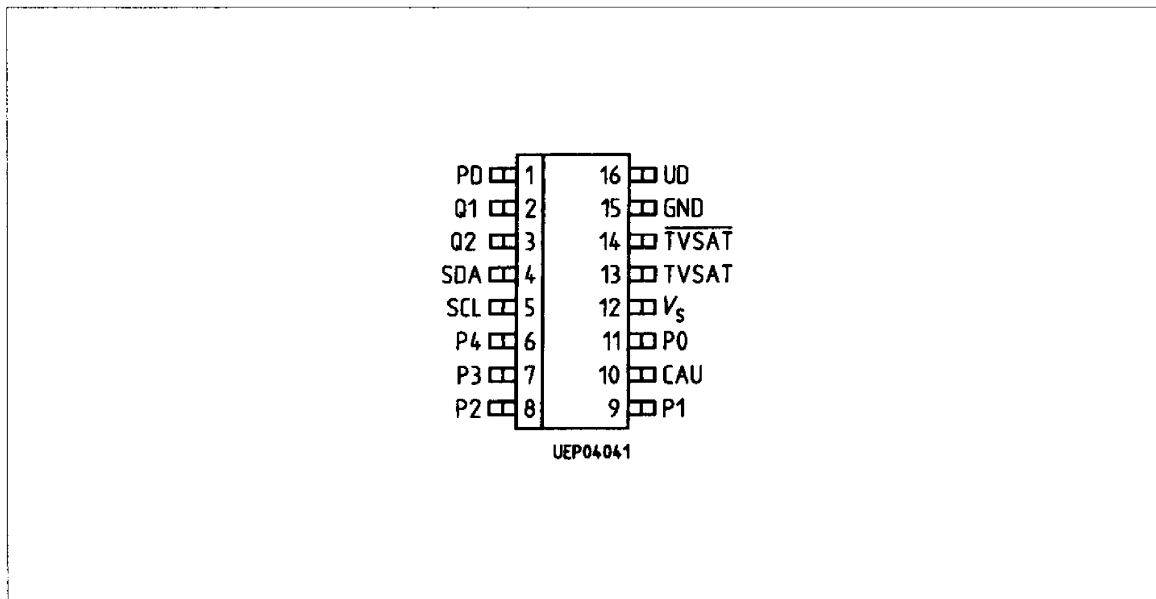

**Pin Configuration**  
(top view)

**Pin Definitions and Functions**

Pin No.	Symbol	Function
1	PD	Input active filter / charge pump output
2	Q1	Quartz crystal
3	Q2	Quartz crystal
4	SDA	Data input / output for I <sup>2</sup> C bus
5	SCL	Clock input for I <sup>2</sup> C bus
6	P4	Port output (open collector)
7	P3	Port output (open collector)
8	P2	Port output (open collector)
9	P1	Port output (open collector)
10	CAU	Address switch input
11	P0	Port output (open collector)
12	V <sub>S</sub>	Supply voltage
13	TVSAT	Non-inverting signal input
14	$\overline{\text{TVSAT}}$	Inverting signal input
15	GND	Ground
16	UD	Output active filter

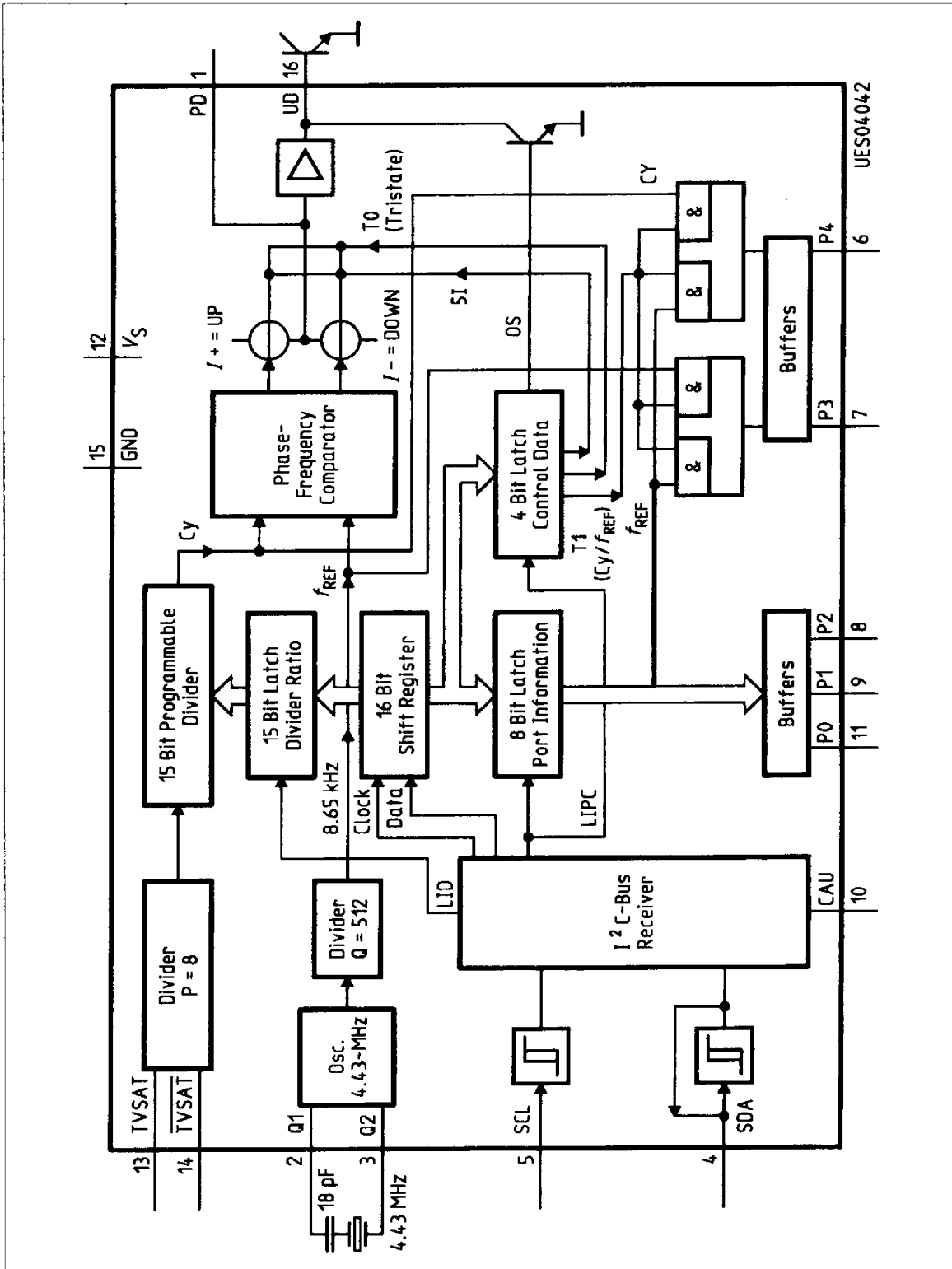

Block Diagram

## Circuit Description

### Tuning Section (refer to block diagram)

- TVSAT,  $\overline{\text{TVSAT}}$**  The tuner signal is capacitively coupled as a differential signal at the TVSAT/ $\overline{\text{TVSAT}}$  inputs. Alternatively, the tuner signal is capacitively coupled at the TVSAT-input and the  $\overline{\text{TVSAT}}$  input is decoupled to ground using a capacitor of low series inductance. The signal subsequently passes through an asynchronous divider with a fixed ratio of  $P = 8$ , an adjustable divider with ratio  $N = 256$  through 32767, and is then compared in a digital frequency/phase detector to a reference frequency  $f_{\text{REF}} = 8.65 \text{ KHz}$ .
- Q1, Q2** This frequency is derived from a balanced, low-impedance 4.43 MHz crystal oscillator (pin Q1, Q2) by dividing its output signal by  $Q = 512$ . The phase detector has two outputs UP and DOWN that drive the two current sources  $I +$  and  $I -$  of a charge pump. If the negative edge of the divided VCO-signal appears prior to the negative edge of the reference signal, the  $I +$  current source pulses for the duration of the phase difference. In the reserve case the  $I -$  current source pulses.
- PD, UD** If the two signals are in phase, the charge pump output (PD) goes into the high-impedance state (PLL is locked). An active low-pass filter integrates the current pulses to generate the tuning voltage for the VCO (internal amplifier, external output transistor at UD and external RC-circuitry). The charge pump output is also switched into the high-impedance state when the control bit  $T0 = 1$ . Here it should be noted, however, that the tuning voltage can alter over a long period in the high-impedance state as a result of selfdischarge in the peripheral circuitry. UD may be switched off by the control bit OS to allow external adjustments. By means of a control bit 5I the pump current can be switched between two values by software. This programmability permits alteration of the control response of the PLL in the locked-in state. In this way different VCO gains in the different TV-bands can be compensated, for example.
- P0 ... P4** The software-switched ports P0 ... P4 are general-purpose 20 mA open-collector outputs and can be used for direct band selection. The test bit  $T1 = 1$  switches the test signals  $f_{\text{REF}}$  (4.43 MHz/512) and Cy (divided input signal) to P3 and P4 respectively.
- CAU** Four different chip addresses can be set by appropriate connection of pin CAU.

### I<sup>2</sup>C- Bus Interface

Data are exchanged between the processor and the PLL on the I<sup>2</sup>C-bus.

**SCL, SDA** The clock is generated by the processor (input SCL), while pin SDA works as an input or output depending on the direction of the data (open collector; external pull-up resistor).

Both inputs have hysteresis and a low-pass characteristic, which enhances the noise immunity of the I<sup>2</sup>C-bus.

The data from the processor pass through an I<sup>2</sup>C-bus control. Depending on their function the data are subsequently stored in registers. If the bus is free, both lines will be in the marking state (SDA, SCL are high). Each telegram begins with the start condition and ends with the stop condition. Start condition: SDA goes low, while SCL remains high.

Stop condition: SDA goes high, while SCL remains high. All further information transfer takes place during SCL = low, and the data is forwarded to the control logic on the positive clock edge.

The table „bit allocation“ should be referred to in the following paragraph.

All telegrams are transmitted byte-by-byte, followed by a ninth clock pulse, during which the control logic returns the SDA-line to low (acknowledge condition). The first byte is comprised of seven address bits. These are used by the processor to select the PLL from several peripheral components (chip select). The eighth bit is always low.

In the data portion of the telegram the first bit of the first or third data byte determines whether a divider ratio or control information is to follow. In each case the second byte of the same data type or a stop condition has to follow the first byte.

$V_S$ , GND When the supply voltage is applied, a power-on reset circuit prevents the PLL from setting the SDA-line to low, which would block the bus.

## Circuit Description (cont'd)

### Bit Allocation

	MSB					A = Acknowledge			
Address byte	1	1	0	0	0	MA1	MA0	0	A
Prog. divider Byte 1	0	n14	n13	n12	n11	n10	n9	n8	A
Prog. divider Byte 2	n7	n6	n5	n4	n3	n2	n1	n0	A
Control info Byte 1	1	5I	T1	T0	1	1	1	OS	A
Control info Byte 2	P4	P3	P2	P1	X	X	P0	X	A

### Divider Ratio

$$N = 16384 \times n14 + 8192 \times n13 + 4096 \times n12 + 2048 \times n11 + 1024 \times n10 + 512 \times n9 + 256 \times n8 + 128 \times n7 + 64 \times n6 + 32 \times n5 + 16 \times n4 + 8 \times n3 + 4 \times n2 + 2 \times n1 + n0$$

### Port Switching

P0 ... P4 = 1      Open-collector output is active.

### Pump Current Programming

5I = 1      High current

### UD Disable

OS = 1      UD is disabled

### Test Mode

T1, T0 = 0, 0      Normal operation  
 T1 = 1      P3 =  $f_{REF}$ , P4 = Cy  
 T0 = 0      Tristate: charge pump output PD is in high-impedance state.

### Chip Address Switching

MA1	MA0	Voltage at CAU
0	0	(0 ... 0.1) $V_S$
0	1	open-circuit
1	0	(0.4 ... 0.6) $V_S$
1	1	(0.9 ... 1) $V_S$

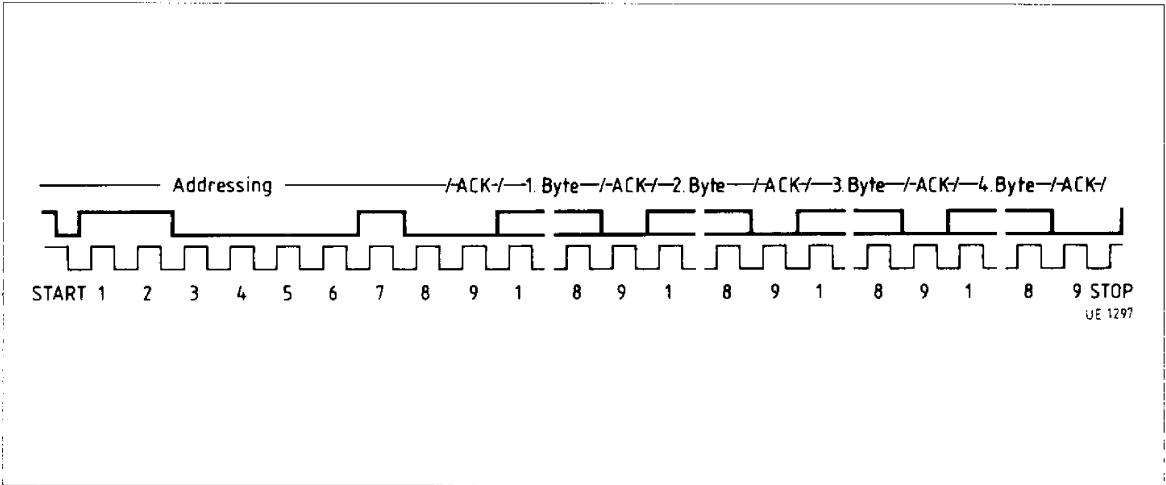

**Pulse Diagram**

**Telegram Examples**

- Start-Addr-DR1-DR2-CW1-CW2-Stop
- Start-Addr-CW1-CW2-DR1-DR2-Stop
- Start-Addr-DR1-DR2-CW1-Stop
- Start-Addr-CW1-CW2-DR1-Stop
- Start-Addr-DR1-DR2-Stop
- Start-Addr-CW1-CW2-Stop
- Start-Addr-DR1-Stop
- Start-Addr-CW1-Stop

- Start = start condition
- Addr = address
- DR1 = divider ratio 1st byte
- DR2 = divider ratio 2nd byte
- CW1 = control word 1st byte
- CW2 = control word 2nd byte
- Stop = stop condition

## Absolute Maximum Ratings

$T_A = -20$  to  $80$  °C

Parameter	Symbol	Limit Values		Unit	Remarks
		min.	max.		
Supply voltage	$V_S$	- 0.3	6	V	
Output PD	$V_1$	- 0.3	$V_S$	V	
Crystal oscillator pins Q1, Q2	$V_2$	- 0.3	$V_S$	V	
Bus input/output SDA	$V_4$	- 0.3	6	V	
Bus input SCL	$V_5$	- 0.3	6	V	
Port outputs P0 ... P4	$V_6$	- 0.3	16	V	
Chip address switch CAU	$V_{10}$	- 0.3	$V_S$	V	
Signal inputs TVSAT, $\overline{\text{TVSAT}}$	$V_{13}$	- 0.3	0.3	V	for $V_S = 0$ V
Output active filter UD	$V_{16}$	- 0.3	$V_S$	V	
Bus output SDA	$I_{4L}$	- 1	5	mA	open collector
Port outputs P0 ... P4	$I_{6L}$	- 1	20	mA	open collector
Total port output current	$\Sigma I_L$		25	mA	
Junction temperature	$T_j$		125	°C	
Storage temperature	$T_{stg}$	- 40	125	°C	
Thermal resistance (junction to ambient)	$R_{th JA}$		125	K/W	

## Operating Range

Supply voltage	$V_S$	+ 4.5	5.5	V	
Ambient temperature	$T_A$	- 20	80	°C	
Input frequency	$f_{13}$		2400	MHz	(at 25 °C)
Crystal frequency	$f_2$		4.69	MHz	
Programmable divider factor	$N$	256	32767		

**AC/DC-Characteristics**

$T_A = -20$  to  $80$  °C;  $V_S = 4.5$  to  $5.5$  V

Parameter	Symbol	Limit Values			Unit	Test Condition	Test Circuit
		min.	typ.	max.			
Supply current	$I_S$		45	59	mA	$V_S = 5$ V	1
Crystal oscillator frequency	$f_2$		4.43		MHz	series capacitance 18 pF $f_{xtal} = 4.43$ MHz	1
Oscillator amplitude (voltage across crystal)*			2.6		V		
Margin from 1st (fundamental) to 2nd and 3rd harmonics*			20		dB		

**Signal Input TVSAT/TVSAT**

Sensitivity in mVrms into 50 Ω	$a_{13}$	- 10/ 71		3/315	dBm	$f_{13} = 500$ MHz ... 2.4 GHz	2
--------------------------------	----------	-------------	--	-------	-----	--------------------------------	---

**Port Outputs P0 ... P4 (switch with open collector)**

H-input current	$I_{6H}$			10	μA	$V_{6H} = 13.5$ V	3
L-output voltage	$V_{6L}$			0.5	V	$I_{6L} = 20$ mA	3
The sum of the currents in ports P0 to P4 may not exceed 25 mA.							

**Phase-Detector Output PD ( $V_S = 5$  V)**

Pump current	$I_{1H}$	± 90	± 220	± 300	μA	5I = high; $V_1 = 2$ V	4
Pump current	$I_{1H}$	± 22	± 50	± 75	μA	5I = low; $V_1 = 2$ V	4
Tristate current	$I_{1Z}$	- 5	0	+ 5	nA	T1 = 1; $V_1 = 2$ V	4
Output voltage	$V_{1L}$	1.0		2.5	V	locked	4

**Active Filter Output UD (Test mode T0 = 1; PD = tristate)**

Output current	$-I_{16}$	500			μA	$V_{16} = 0.8$ V; $I_{1H} = 90$ μA	4
Output voltage	$V_{16}$			100	mV	$V_{1L} = 0$ V	4
Output voltage	$V_{16}$			500	mV	OS = 1	4

**Chip Address Switch CAU**

Input current	$I_{10H}$			50	μA	$V_{10H} = 5$ V	6
Input current	$-I_{10H}$			50	μA	$V_{10H} = 0$ V	6

\* Design note only: no 100% final inspection

**AC/DC Characteristics (cont'd)**

$T_A = -20$  to  $80$  °C;  $V_S = 4.5$  to  $5.5$  V

Parameter	Symbol	Limit Values			Unit	Test Condition	Test Circuit
		min.	typ.	max.			

**Bus Input SCL, SDA**

H-input voltage	$V_{4IH}$	3		5.5	V		5
L-input voltage	$V_{4IL}$			1.5	V		5
H-input current	$I_{4IH}$			10	$\mu$ A	$V_{4IH} = V_S$	5
L-input current	$-I_{4IL}$			20	$\mu$ A	$V_{4IH} = 0$ V	5

**Bus Output SDA (open collector)**

H-output current	$I_{4OH}$			10	$\mu$ A	$V_{4H} = 5.5$ V	5
L-output voltage	$V_{4OL}$			0.4	V	$I_{4L} = 3$ mA	5

**Edges SCL, SDA**

Rise time	$t_R$			1	$\mu$ s		5
Fall time	$t_F$			0.3	$\mu$ s		5

**Shift Clock SCL**

Frequency	$f_S$	0		100	kHz		5
H-pulse width	$t_{5H}$	4			$\mu$ s		5
L-pulse width	$t_{5L}$	4.7			$\mu$ s		5

**Start**

Set-up time	$t_{SUSTA}$	4.7			$\mu$ s		5
Hold time	$t_{HDSTA}$	4			$\mu$ s		5

**Stop**

Set up time	$t_{SUSTO}$	4.7			$\mu$ s		5
Bus free	$t_{BUF}$	4.7			$\mu$ s		5

**Data Transfer**

Set-up time	$t_{SUDAT}$	0.25			$\mu$ s		5
Hold time	$t_{HDDAT}$	0			$\mu$ s		5
Input hysteresis SCL, SDA*			300		mV		
Low-pass cutoff frequency SCL, SDA*			500		kHz		

\* Design note only: no 100% final inspection

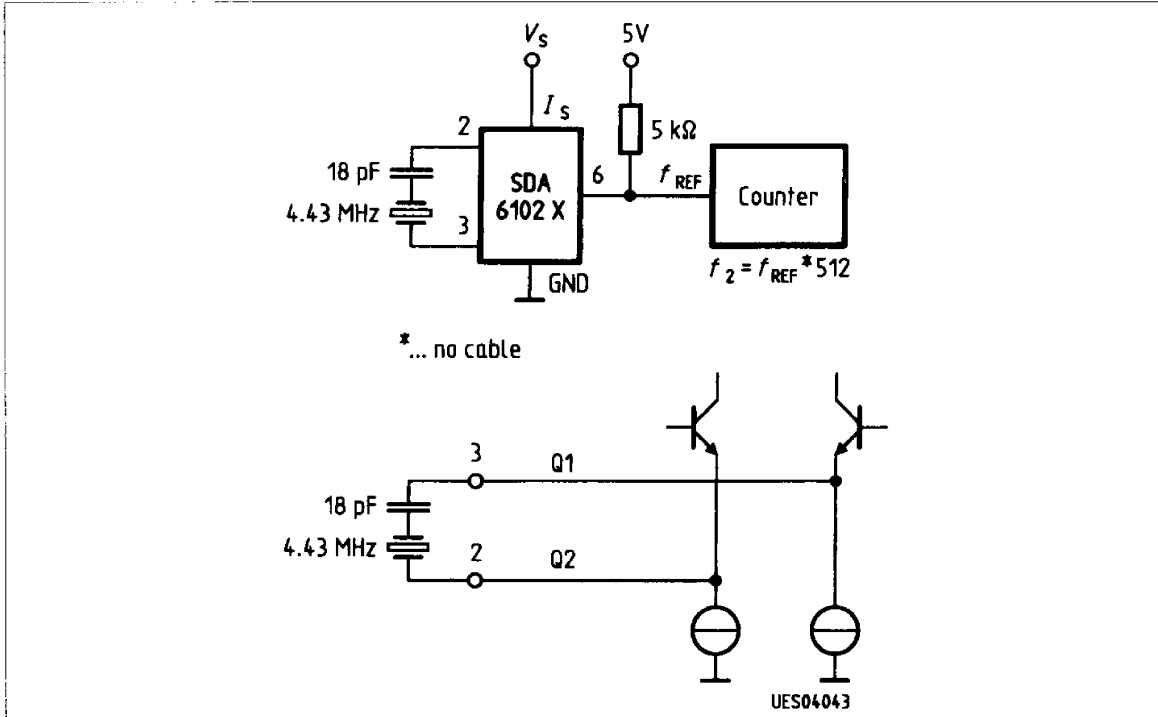

Test Circuit 1

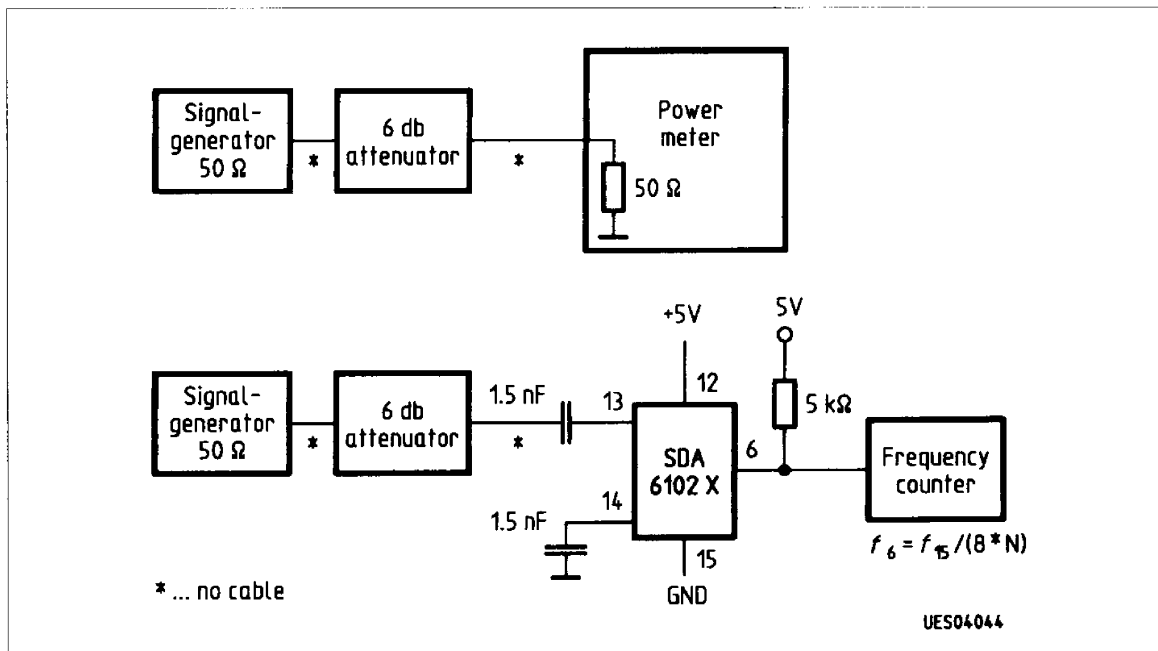

Test Circuit 2

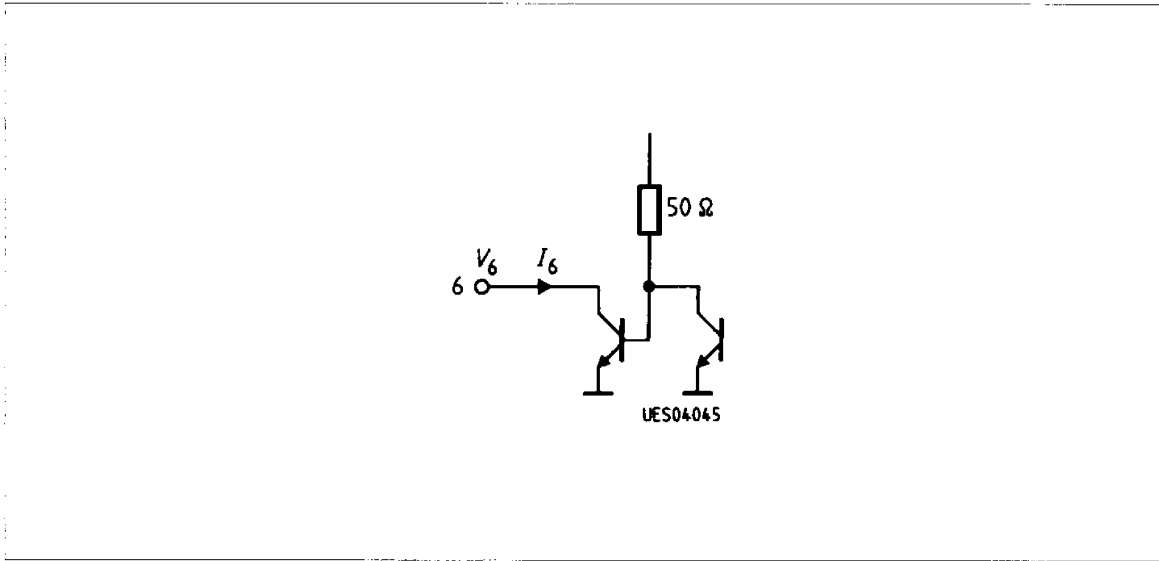

Test Circuit 3

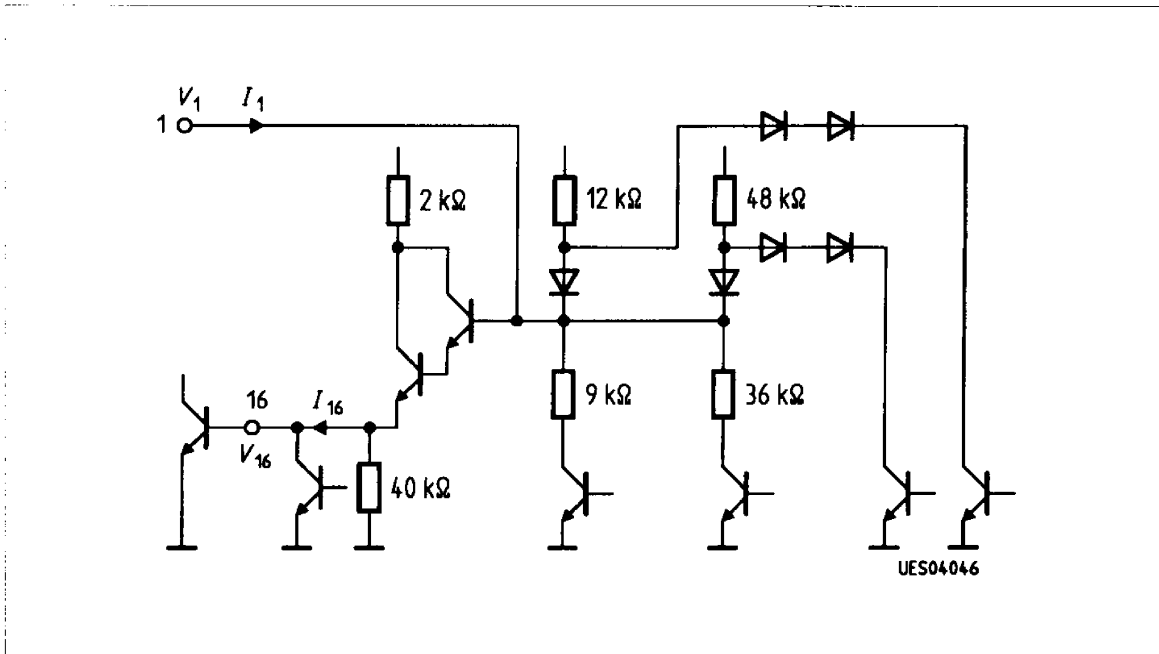

Test Circuit 4

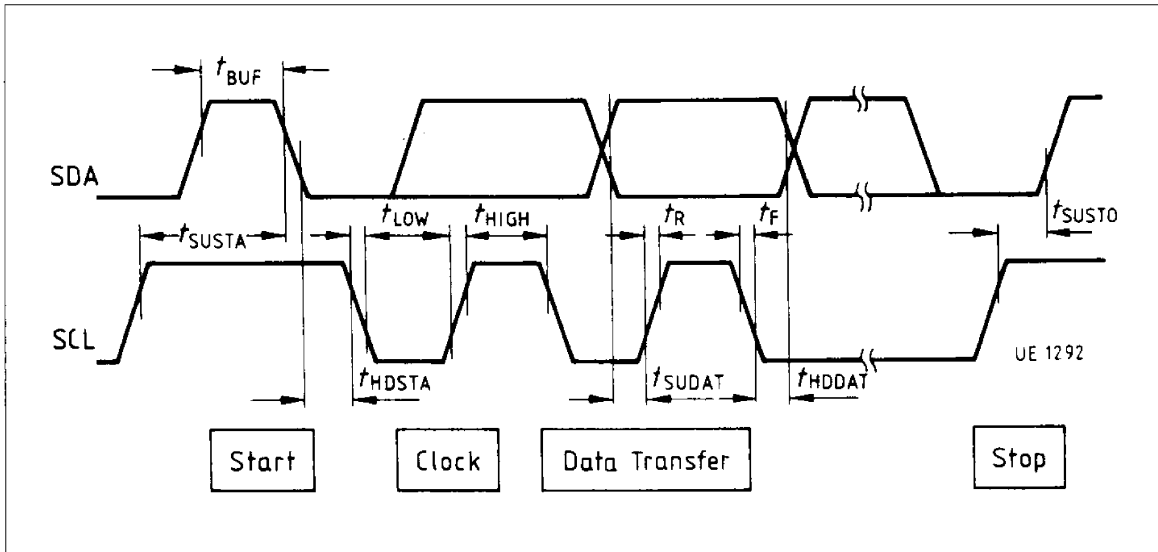

**Test Circuit 5**

- $t_{SUSTA}$  Set-up time (start)
- $t_{HDSTA}$  Hold time (start)
- $t_{HIGH}$  H-pulse width (clock)
- $t_{LOW}$  L-pulse width (clock)
- $t_{SUDAT}$  Setup time (data transfer)
- $t_{HDDAT}$  Hold time (data transfer)
- $t_{SUSTO}$  Set-up time (stop)
- $t_{BUF}$  Bus free time
- $t_F$  Fall time
- $t_R$  Rise time

All times related to 10 % and 90 % values

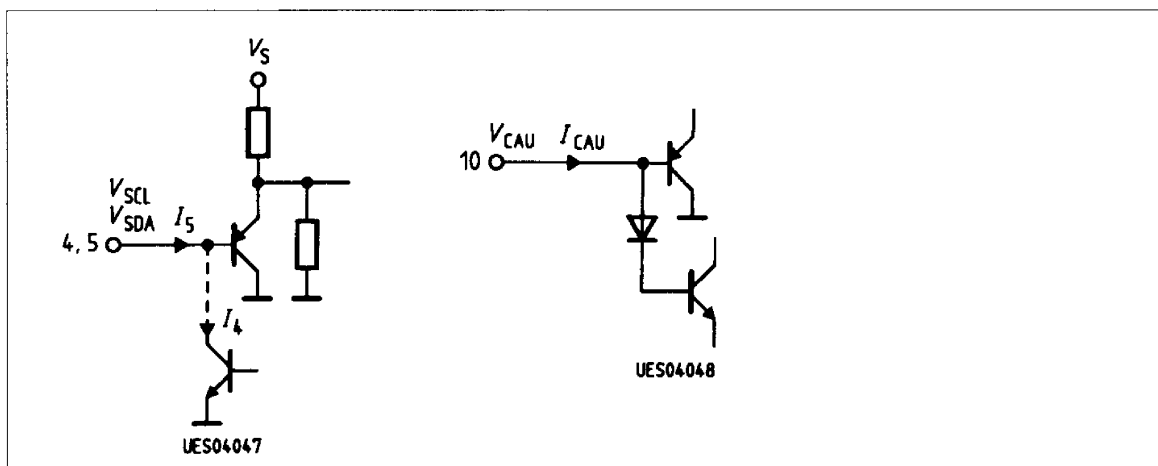

**Test Circuit 6**

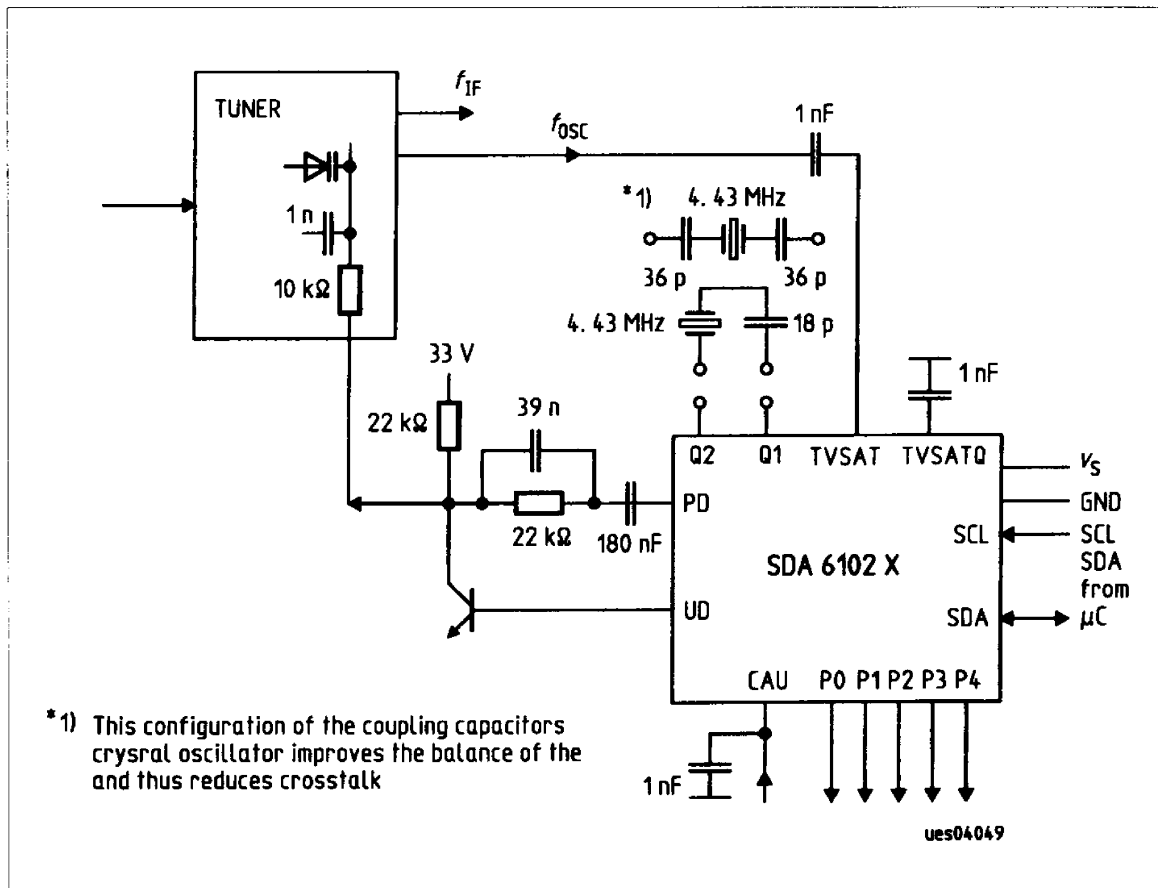

Application Circuit

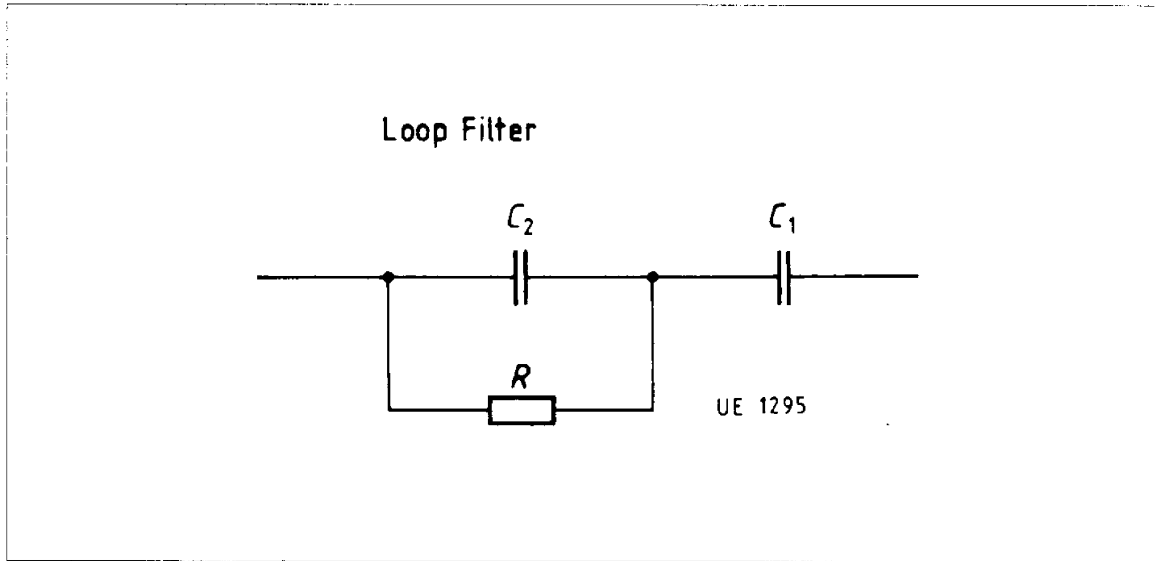
**Application Circuit****Calculation of loop filter**

Loop bandwidth:  $\omega_R = \sqrt{(I_P \times K_{VCO}) / (C_1 \times P \times N)}$

Attenuation:  $a = 0.5 \times \omega_R \times R \times C_1$

$P$  = prescaler

$N$  = programmable divider

$I_P$  = pump current

$K_{VCO}$  = tuner slope

$R, C_1$  = loop filter

**Example**

$P = 8, N = 11520, I_P = 50 \mu\text{A}; K_{VCO} = 18.7 \text{ MHz/V}, R = 22 \text{ k}\Omega,$   
 $C_1 = 180 \text{ nF}; \omega_R = 237 \text{ Hz}, f_r = 38 \text{ Hz}, a = 0.67$

**Note:** The high-impedance port outputs and CAU can be decoupled from external noise with a capacitor of 1 nF.

It is important to keep to the I<sup>2</sup>C-bus specification concerning maximum capacitance and impedance.

**Sensitivity at TVSAT/TVSAT Input**  
(typical at 25 °C)

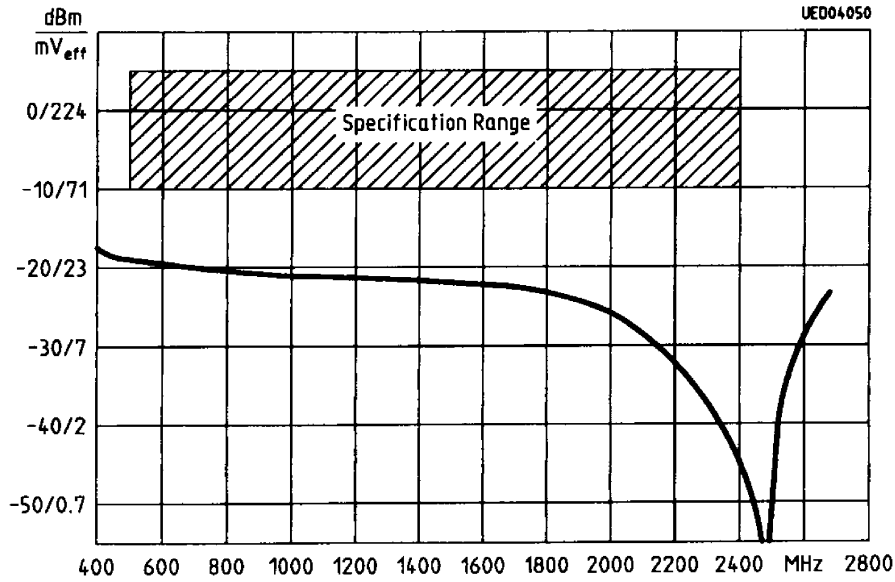

**I<sup>2</sup>C-Bus Noise Immunity**

Sinusoidal Noise Pulses are Applied via a Coupling Capacitance of 33 pF to the SCL- and SDA-Inputs

