

TENTATIVE TOSHIBA BIPOLAR LINEAR INTEGRATED CIRCUIT SILICON MONOLITHIC

TA8750AN

SECAM CHROMA PROCESSOR

The TA8750AN is a SECAM chroma processor packaged in a 36 lead, shrink type, dual in line plastic package.

The TA8750AN includes all of the functions required to realize a PAL/SECAM CTV in conjunction with a PAL single chip IC TA8691N or a PAL/NTSC single chip IC TA8690AN.

The TA8750AN is also able to be used with the TA7698AP (PAL/NTSC V/C/D).

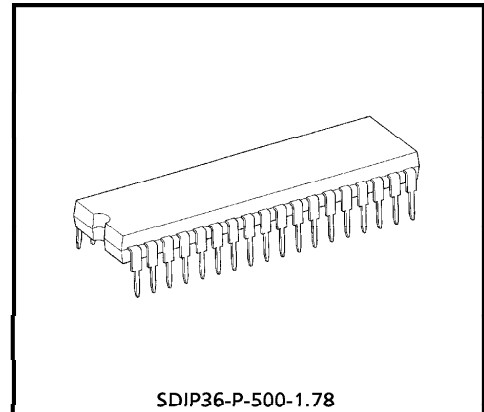

Weight : 2.98g (Typ.)

FEATURES

- SECAM limiter
- PAL/SECAM switch for 1H DL drive circuit
- SECAM demodulator
- De-emphasis
- Color control
- Uni-color control
- Clamp circuits for PAL color-difference signals
- PAL/SECAM SW
- G-Y matrix
- Gate pulse generator (H ID/V ID)
- OSD interface

961001EBA2

- TOSHIBA is continually working to improve the quality and the reliability of its products. Nevertheless, semiconductor devices in general can malfunction or fail due to their inherent electrical sensitivity and vulnerability to physical stress. It is the responsibility of the buyer, when utilizing TOSHIBA products, to observe standards of safety, and to avoid situations in which a malfunction or failure of a TOSHIBA product could cause loss of human life, bodily injury or damage to property. In developing your designs, please ensure that TOSHIBA products are used within specified operating ranges as set forth in the most recent products specifications. Also, please keep in mind the precautions and conditions set forth in the TOSHIBA Semiconductor Reliability Handbook.
- The products described in this document are subject to foreign exchange and foreign trade control laws.
- The information contained herein is presented only as a guide for the applications of our products. No responsibility is assumed by TOSHIBA CORPORATION for any infringements of intellectual property or other rights of the third parties which may result from its use. No license is granted by implication or otherwise under any intellectual property or other rights of TOSHIBA CORPORATION or others.
- The information contained herein is subject to change without notice.

BLOCK DIAGRAM

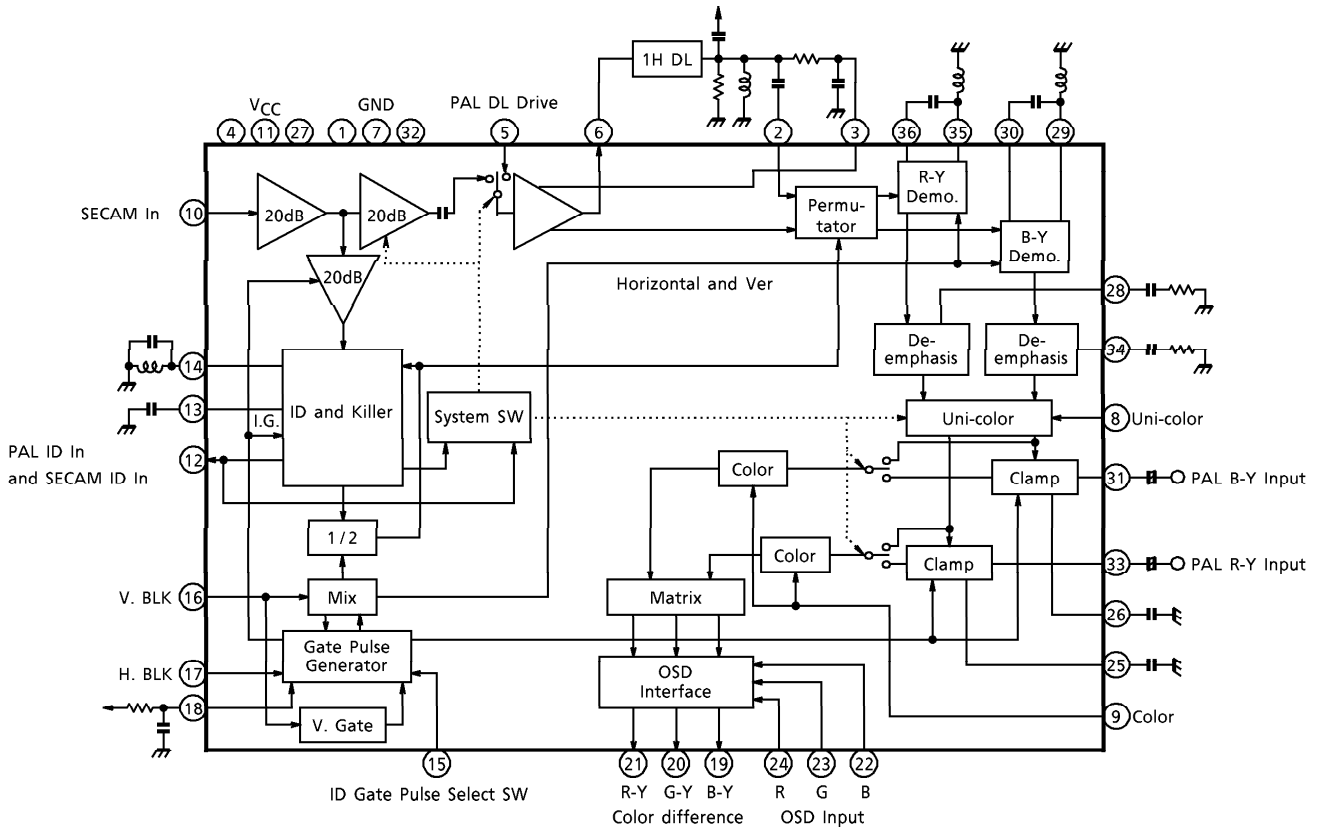

TERMINAL FUNCTION

PIN No.	PIN NAME	FUNCTION	INTERFACE CIRCUIT
1	GND1	This is the ground for R-Y demodulator, R-Y de-emphasis and R-Y clamp circuits.	—
2 3	DL Input Bias	The input terminal of 1H delayed chroma signal for the SECAM Permutator.	
4	VCC1	This is the power supply for the DL circuit. Recommended supply voltage is 9V.	—
5	PAL DL Input	A PAL chroma signal is led from the TA8690AN, TA8691N. An internal system switch selects this PAL signal or SECAM signal according to the system ID signal, and delivers to a DL drive circuit.	
6	DL Drive	The PAL/SECAM chroma signal output (switched by internal system switch) for a 1H delay line. Connect a load resistor of 2kΩ to GND.	
7	GND2	This is the ground for DL input, permutator, system switch, gate pulse generator and chroma amplitude circuits.	—
8	Uni-color	Color saturation of SECAM signal increases when the terminal voltage of pin 7 increases.	
9	Color	Color saturation (both SECAM and PAL) increases when the terminal voltage of pin 6 increases.	

PIN No.	PIN NAME	FUNCTION	INTERFACE CIRCUIT
10	SECAM Input	SECAM chroma signal is led to this terminal through a bell filter circuit.	
11	VCC2	This is the power supply for the DL, permutator, system switch, gate pulse generator and chroma amplitude circuits. Recommended supply voltage is 9V.	—
12	PAL ID In and SECAM ID In	An input terminal of a PAL ID signal. In case the DC voltage of more than 2V is applied to this terminal, the system switched to the PAL mode. When the SECAM ID circuit detects the SECAM signal, the terminal pin 10 goes to low. So, in case that this terminal is connected to the PAL color control terminal, then the system ID priority is set to SECAM.	
13	ID Filter	Hold capacitance for SECAM idification is connected.	
14	ID Coil	A 4.328MHz tuned tank circuit for SECAM idification is connected. Adjust tank coil so that the recovered DC voltage at the terminal 20 is maximum value for 4.328MHz.	

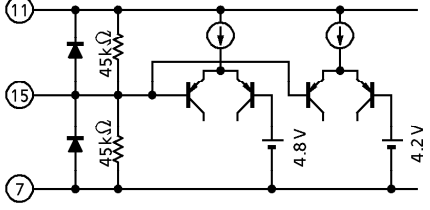
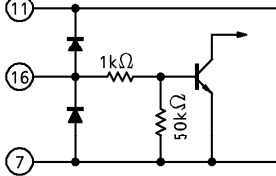
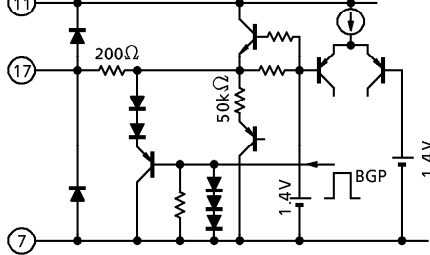
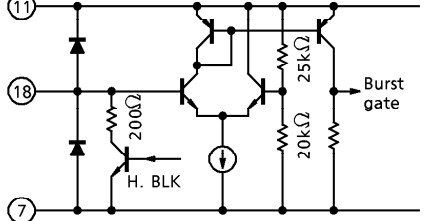
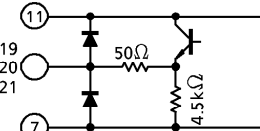
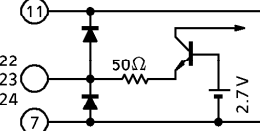
PIN No.	NAME	FUNCTION	INTERFACE CIRCUIT								
15	Gate Switch	Switch of SECAM identification detection. <table border="1" data-bbox="475 544 887 707" style="margin-left: auto; margin-right: auto;"> <thead> <tr> <th>PIN VOLTAGE</th> <th>DETECTED ID</th> </tr> </thead> <tbody> <tr> <td>4.0V -</td> <td>Only V ID.</td> </tr> <tr> <td>4.5V</td> <td>Only H ID.</td> </tr> <tr> <td>5.0V +</td> <td>Both of V and H ID.</td> </tr> </tbody> </table>	PIN VOLTAGE	DETECTED ID	4.0V -	Only V ID.	4.5V	Only H ID.	5.0V +	Both of V and H ID.	
PIN VOLTAGE	DETECTED ID										
4.0V -	Only V ID.										
4.5V	Only H ID.										
5.0V +	Both of V and H ID.										
16	V. BLK Input	An input terminal of V. BLK pulse.									
17	H. BLK Input	An input terminal of flyback pulse for H. BLK, internal flip flop driving, and gate pulse generator. During gate pulse period, the pin 22 voltage becomes 4.2V (Typ.)									
18	Gate Pulse Filter	Time constant for gate pulse generator is connected.									
19 20 21	B-Y Output G-Y Output R-Y Output	Color-difference signal output.									
22 23 24	OSD B Input OSD G Input OSD R Input	Input for OSD. OSD turn ON by 300mA + current drawn out of these pins.									

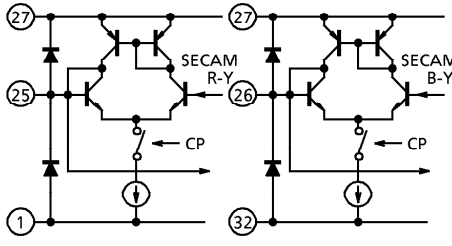
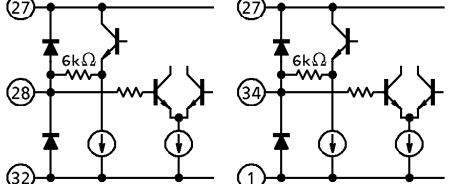
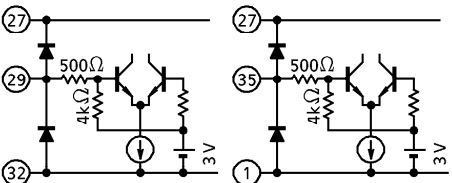
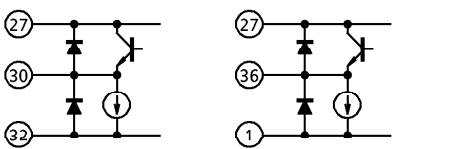
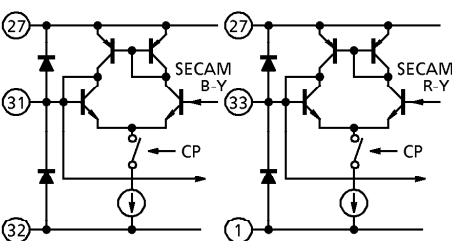
PIN No.	NAME	FUNCTION	INTERFACE CIRCUIT
25 26	R-Y Clamp B-Y Clamp	Clamp capacitance for the color-difference signal path is connected.	
27	VCC3	The pin for VCC. Supply 9V.	—
28 34	De-emphasis (B-Y) De-emphasis (R-Y)	SECAM de-emphasis. Connect a resistor and capacitor to GND for SECAM de-emphasis.	
29 35	B-Y Demo. R-Y Demo.	SECAM B-Y detector. A 4.250MHz tuned tank circuit for SECAM B-Y demodulator is connected.	
30 36	B-Y Limiter Output R-Y Limiter Output	SECAM R-Y detector. A 4.406MHz tuned tank circuit for SECAM R-Y demodulator is connected.	
32	GND3	The pin for GND.	—
31 33	PAL B-Y Input PAL R-Y Input	An input terminal of a PAL color-difference signal. An input clamp circuit coincides the input bias voltage with a corresponding SECAM bias voltage. An internal system SW selects a PAL color difference signal or a SECAM color difference signal according to the system ID signal.	

MAXIMUM RATINGS (Ta = 25°C)

CHARACTERISTIC	SYMBOL	RATING	UNIT
Power Supply Voltage	V _{CC}	13	V
Power Dissipation	P _{Dmax}	1600 (Note)	mW
Input Signal Voltage	e _{in}	5	V _{p-p}
Operating Temperature	T _{opr}	- 20~65	°C
Storage Temperature	T _{stg}	- 55~150	°C

(Note) When using the device at above Ta = 25°C, decrease the power dissipation by 12.8mW for each increase of 1°C.

ELECTRICAL CHARACTERISTICS

DC VOLTAGE CHARACTERISTICS (Unless otherwise specified, V_{CC} = 9V, Ta = 25°C)

PIN No.	CHARACTERISTIC	SYMBOL	TEST CONDITION	MIN.	TYP.	MAX.	UNIT
1	GND1	GND1	—	—	—	—	V
2	DL Input	V ₂	—	—	—	—	V
3	Bias	V ₃	—	3.9	4.3	4.7	V
4	V _{CC1}	V _{CC1}	—	—	—	—	V
5	PAL DL Input	V ₅	—	3.9	4.3	4.7	V
6	DL Drive	V ₆	—	4.9	5.6	6.2	V
7	GND2	GND2	—	—	—	—	V
8	Uni-color	V ₈	—	—	—	—	V
9	Color	V ₉	—	—	—	—	V
10	SECAM Input	V ₁₀	—	7.3	7.7	8.0	V
11	V _{CC2}	V _{CC2}	—	—	—	—	V
12	PAL ID and SECAM ID Output	V ₁₂	—	—	—	—	V
13	ID Filter	V ₁₃	—	5.6	6.0	6.4	V
14	ID Coil	V ₁₄	—	3.5	3.9	4.3	V
15	Gate Switch	V ₁₅	—	4.3	4.5	4.7	V
16	V. BLK Input	V ₁₆	—	—	—	—	V
17	H. BLK Input	V ₁₇	—	0.4	1.4	1.8	V

PIN No.	CHARACTERISTIC	SYMBOL	TEST CONDITION	MIN.	TYP.	MAX.	UNIT
18	Gate Pulse Filter	V ₁₈	—	—	—	—	V
19	B-Y Output	V ₁₉	—	5.0	5.5	6.0	V
20	G-Y Output	V ₂₀	—	5.0	5.5	6.0	V
21	R-Y Output	V ₂₁	—	5.0	5.5	6.0	V
22	OSD B Input	V ₂₂	—	1.4	1.7	2.1	V
23	OSD G Input	V ₂₃	—	1.4	1.7	2.1	V
24	OSD R Input	V ₂₄	—	1.4	1.7	2.1	V
25	R-Y Clamp	V ₂₅	—	—	—	—	V
26	B-Y Clamp	V ₂₆	—	—	—	—	V
27	VCC3	VCC3	—	—	—	—	V
28	B-Y De-emphasis	V ₂₈	—	3.6	4.5	5.3	V
29	B-Y Demo.	V ₂₉	—	2.7	3.0	3.3	V
30	B-Y Limiter Output	V ₃₀	—	6.1	6.8	7.5	V
31	PAL B-Y Input	V ₃₁	—	—	—	—	V
32	GND3	GND3	—	—	—	—	V
33	PAL R-Y Input	V ₃₃	—	—	—	—	V
34	R-Y De-emphasis	V ₃₄	—	3.6	4.5	5.3	V
35	R-Y Demo.	V ₃₅	—	2.7	3.0	3.3	V
36	R-Y Limiter Output	V ₃₆	—	6.1	6.8	7.5	V

AC CHARACTERISTICS (Unless otherwise specified, V_{CC} = 9V, T_a = 25°C)

CHARACTERISTIC	SYMBOL	TEST CIRCUIT	TEST CONDITION	MIN.	TYP.	MAX.	UNIT
SECAM Input Impedance	Z ₁₀	—	(Note 1)	2.1	3.0	3.9	kΩ
SECAM Priority Switch Voltage	V _{SWSCM}	—	(Note 2)	5.0	5.8	—	V
SECAM Limiter Gain	G _{LIM}	—	(Note 3)	30	40	—	dB
SECAM ID Voltage	V _{IDSCM}	—		6.3	6.6	—	V
SECAM Acknowledge Voltage	V _{ACSCM}	—	(Note 4)	—	0.0	0.3	V
SECAM ID Sensitivity	S _{IDSCM}	—		0.5	1.0	2.0	mV _{p-p}
PAL ID Input Detection Voltage	V _{PAL}	—	(Note 5)	1.0	1.4	—	V
PAL Drive Input Impedance	Z ₅	—	(Note 6)	28	40	52	kΩ
DL Amp. Gain	G _{DL}	—	(Note 7)	-1.0	2.0	4.0	dB
PAL Drive Input Dynamic Range	D ₅	—		1.6	2.0	2.4	V _{p-p}
SECAM Detector Band Width	BW _{DEMO}	—	(Note 8)	±500	—	—	kHz
SECAM Detector AMR Characteristics	AMR	—	(Note 9)	30	40	—	dB
R-Y Output Amplitude	v ₂₈	—	(Note 10)	0.6	1.0	1.5	V _{p-p}
B-Y Output Amplitude	v ₃₄	—		0.45	0.71	1.05	
R-Y Relative Gain	R-Y/B-Y	—	(Note 11)	0.43	0.58	0.70	
G-Y Relative Gain	G-Y/B-Y	—		0.27	0.37	0.46	

CHARACTERISTIC	SYMBOL	TEST CIRCUIT	TEST CONDITION	MIN.	TYP.	MAX.	UNIT
Residual Carrier Level	v_{LEAK}	—	(Note 12)	—	—	100	mV _{p-p}
Color Difference Dynamic Range	D ₃₁ D ₃₃	—	(Note 13)	2.5	3.0	—	V _{p-p}
Uni-color Control Voltage	V _g	—	(Note 14)	4.0	4.5	5.0	V
Uni-color Control Voltage Range	ΔV_g			1	2	2	V
Uni-color Gain Control Range	ΔG_g			16	18	—	dB
Color Control Voltage	V _g	—	(Note 15)	4.0	4.5	5.0	V
Color Control Voltage Range	ΔV_g			1.5	2.0	2.5	V
Color Gain Control Range	ΔG_g			16	18	—	dB
Color Difference Output Blanking Voltage	V _{BLK}	—	(Note 16)	5.0	5.5	6.0	V
Color Difference Output Blanking Voltage Difference	ΔV_{BLK}			—	—	0.1	V
V. BLK Det Voltage	V _{thVBLK}	—	(Note 17)	2.0	2.2	2.5	V
H. BLK Det Voltage	V _{thVBLK}			1.1	1.4	1.7	V
H. Gate Pulse Phase	t _{Hphs}	—	(Note 18)	7.0	7.5	8.0	μs
H. Gate Pulse Width	t _{Hwid}			3.0	3.5	4.0	μs
H. Gate Pulse Output High Level	V _{HBHI}			3.9	4.2	4.8	V
H. Gate Pulse Output Low Level	V _{HBLO}			1.9	2.2	2.5	V
V. Gate Pulse Phase	t _{Vphs}	—	(Note 19)	7	8	9	H
V. Gate Pulse Width	t _{Vwid}			5	6	7	H
Gate Pulse Switching Level	V _{GSWH}	—	(Note 20)	—	4.8	5.1	V
	V _{GSWL}			3.9	4.2	—	V
OSD ON Current	I _{ON}	—	(Note 21)	0.2	0.3	0.4	mA
OSD OFF Current	I _{OFF}	—	(Note 22)	0.15	0.22	0.30	mA
OSD Output High Voltage	V _{OSDH}	—	(Note 23)	6.5	6.7	6.9	V
OSD Output Low Voltage	V _{OSDL}	—	(Note 24)	4.4	4.7	5.0	V
OSD Rise Time	t _R	—	(Note 25)	—	15	100	ns
OSD Dising Propagation Time	t _{RD}			—	40	100	ns
OSD Fall Time	t _R			—	25	100	ns
OSD Falling Propagation Time	t _{RD}			—	15	100	ns

MEASUREMENT CONDITION (Unless otherwise specified, $V_{CC} = 9V$, $T_a = 25^\circ C$)

NOTE No.	ITEM	SYMBOL	MEASUREMENT METHOD
1	SECAM Input Impedance	Z_{10}	(1) SW10A : off, SW10B : off (2) Input 4.43 [MHz], 100 [mV _{p-p}] from TP10. (3) Measure 4.43MHz amplitude at pin 10. (v_{10} [mV _{p-p}]) (4) Z_{10} [k Ω] = $20 \log \frac{3 \times v_{10}}{100 - v_{10}}$
2	SECAM Priority Switch Voltage	V_{SWSCM}	(1) SW10A : on, $V_0 = 5$ [V], SW10B : off (2) SW12 : a, $V_{12} = 9$ [V] (3) Input SECAM chroma signal (ID level 100 [mV _{p-p}]) from TP10. (4) Measure pin 12 voltage when pin 12 voltage becomes lower than 0.5 [V] by lowering V_{10} voltage.
3	SECAM Limiter Gain	G_{LIM}	(1) SW10A : on, SW10B : off, SW12 : b (2) Input 4.43 [MHz], 10 [mV _{p-p}] from TP10. (3) Measure 4.43MHz amplitude at pin 6. (v_6 [mV _{p-p}]) (4) G_{LIM} [dB] = $20 \log \frac{v_6}{10}$
4	SECAM ID Voltage SECAM Acknowledge Voltage SECAM ID Sensitivity	V_{IDSCM} V_{ACSCM} S_{IDSCM}	(1) SW10A : on, SW10B : on, $V_{10} = 0$ [V], SW12 : a, $V = 5$ [V] (2) Input SECAM chroma signal (ID level 100 [mV _{p-p}]) from TP10. (3) Adjust ID coil so that pin voltage of pin 13 can be maximum. Measure the pin voltage after adjustment. (V_{IDSCM}) (4) Measure pin voltage of pin 12. (V_{ACSCM}) (5) Measure amplitude of input signal at pin 10 when pin 12 voltage becomes 5 [V] by lowering amplitude of input signal. (S_{IDSCM})
5	PAL ID Detection Voltage	V_{PAL}	(1) SW12 : a, $V_{12} = 0$ [V], SW5A : on, SW5B : a (2) Input 4.43 [MHz], 100 [mV _{p-p}] from TP5. (3) Measure pin voltage of pin 12 when input signal outputted from pin 6 by increasing V_{12} . (V_{PAL})
6	PAL Drive Input Impedance	Z_5	(1) SW5A : off, SW5B : a (2) Input 4.43 [MHz], 100 [mV _{p-p}] from TP5. (3) Measure 4.43MHz amplitude at pin 5. (v_5 [mV _{p-p}]) (4) Z_{10} [k Ω] = $20 \log \frac{47 \times v_5}{100 - v_5}$

NOTE No.	ITEM	SYMBOL	MEASUREMENT METHOD
7	DL Amp. Gain, PAL Drive Input Dynamic Range	G_{DL} D_5	(1) SW5A : on, SW5B : a, SW12 : a, V12 = 5 [V] (2) Input 4.43 [MHz], 100 [mV _{p-p}] from TP5. (3) Measure 4.43MHz amplitude at pin 6. (v_6 [mV _{p-p}]). (4) G_{DL} [dB] = $20\log \frac{v_6}{10}$ (5) Measure amplitude of input signal when signal outputted from pin 6 starts to distort by increasing amplitude of input signal.
8	SECAM Detector Bandwidth	BW_{DEMO}	(1) SW10A : on, SW10B : off, SW12 : b, SW15 : B (2) Apply 9 [V] to pin 13. (3) Input $f_c = 4.25$ [MHz], 100 [dB μ V] which pin 10 is FM modulated by 1 [kHz]. (4) Measure amplitude of 1 [kHz] signal at pin 28. (v_{28}) (5) Measure f_c frequency width v_{28} . (BW_{DEMO})
9	SECAM Detector AMR Characteristics	AMR	(1) SW10A : on, SW10B : off, SW12 : b, SW15 : B (2) Apply 9 [V] to pin 13. (3) Input $f_c = 4.25$ [MHz], 100 [dB μ V] which pin 10 is FM modulated by 1 [kHz]. (4) Measure amplitude of 1 [kHz] signal at pin 28. (v_{FM}) (5) Input $f_c = 4.25$ [MHz], 100 [dB μ V] which pin 10 is AM modulated (30 [%]) by 1 [kHz]. (6) Measure amplitude of 1 [kHz] signal at pin 28. (v_{AM}) (7) AMR [dB] = $20\log \frac{v_{FM}}{v_{AM}}$
10	R-Y Output Amplitude B-Y Output Amplitude	v_{28} v_{34}	(1) SW10A : on, SW10B : off, SW12 : b (2) Input SECAM 75% standard color bar chroma signal from TP10. (3) Measure output amplitude of pins 28 & 34. (v_{28} , v_{34})
11	R-Y Relative Gain B-Y Relative Gain	R-Y/B-Y G-Y/B-Y	(1) SW10A : on, SW10B : off, SW12 : b (2) Adjust VR8 & 9 so that pin 8 & 9 voltage can be 4.5 [V]. (3) Input SECAM rainbow color bar chroma signal from TP10. (4) Measure output amplitude of pins 19, 20 & 21. (v_{19} , v_{20} , v_{21}) (5) R-Y/B-Y = $\frac{v_{21}}{v_{19}}$ G-Y/B-Y = $\frac{v_{20}}{v_{19}}$

NOTE No.	ITEM	SYMBOL	MEASUREMENT METHOD
12	Residual Carrier Level	v_{LEAK}	(1) SW10A : on, SW10B : off, SW12 : b (2) Apply 9 [V] to pin 13. (3) Adjust VR8 & 9 so that pin 8 & 9 voltage can be 4.5 [V]. (4) Input 4.25 [MHz], 100 [dB μ V] to pin 10. (5) Measure amplitude of 4.25 [MHz] component outputted to pin 19. (v_{LEAK})
13	Color Difference Dynamic Range	D ₃₁ D ₃₃	(1) SW12 : a, V12 = 5 [V] (2) Input PAL demodulation color difference signal from TP31 (TP33). (3) Measure amplitude of input signal when signal outputted from pin 6 starts to distort by increasing amplitude of input signal. (D ₃₃)
14	Uni-color Control Voltage Uni-color Control Voltage Range Uni-color Gain Control Range	V _g ΔV_g ΔG_g	(1) SW10A : on, SW10B : off, SW12 : b (2) Input SECAM 75% standard color bar chroma signal from TP10. (3) Measure pin 19 output amplitude by varying pin 8 voltage from 0~9 [V]. (4) If the minimum value of pin 19 output amplitude is 0%, maximum value is 100% and pin 8 voltage is V ₈ at 50%, voltage difference of pin 8 voltage at 10% and 90%. (5) The ratio between maximum and minimum value of pin 19 output amplitude is ΔG_g .
15	Color Control Voltage Color Control Voltage Range Color Gain Control Range	V _g ΔV_g ΔG_g	(1) SW10A : on, SW10B : off, SW12 : b (2) Input SECAM 75% standard color bar chroma signal from TP10. (3) Measure pin 19 output amplitude by varying pin 9 voltage from 0~9 [V]. (4) If the minimum value of pin 19 output amplitude is 0%, maximum value is 100% and pin 9 voltage is V ₉ at 50%, voltage difference of pin 9 voltage at 10% and 90%. (5) The ratio between maximum and minimum value of pin 19 output amplitude is ΔG_g .

NOTE No.	ITEM	SYMBOL	MEASUREMENT METHOD
16	Color Difference Output BLK Voltage Color Difference Output BLK Voltage Difference	V_{BLK} ΔV_{BLK}	(1) SW10A : on, SW10B : off, SW12 : b (2) Adjust VR8 & 9 so that pin 8 & 9 voltage can be 4.5 [V]. (3) Input SECAM 75% standard color bar chroma signal from TP10. (4) Measure voltage of blanking period at TP19, 20 & 21. (V_{BLK}) (5) Measure voltage of each blanking period of TP19, 20 & 21. (ΔV_{BLK})
17	Vertical BLK Detection Voltage Horizontal BLK Detection Voltage	V_{thVBLK} V_{thHBLK}	(1) SW10A : on, SW10B : off, SW12 : b, SW16 : b, V12 = 0 [V], SW17 : c (2) Input SECAM 75% standard color bar chroma signal from TP10. (3) Raise peak value of vertical blanking pulse from 0V. (4) Measure peak value of vertical blanking pulse when vertical blanking starts working. (V_{thVBLK}) (5) Raise peak value of horizontal blanking pulse from 0V. (6) Measure peak value of horizontal blanking pulse which ramp waveform starts to be outputted from pin 18. (V_{thHBLK})
18	H Gate Pulse Phase H Gate Pulse Width H Gate Pulse Output High Level H Gate Pulse Output Low Level	t_{Hphs} t_{Hwid} V_{HBHI} V_{HBLO}	(1) Observe pin 17 waveform of horizontal blanking period. (2) Measure time of the part shown in the diagram. <div data-bbox="874 1279 1305 1480" style="text-align: center;"> </div>
19	V Gate Pulse Phase V Gate Pulse Width	t_{Vphs} t_{Vwid}	(1) SW13 : b, SW15 : c (2) Measure pin 13 waveform of V blanking period. (3) Measure time of the part shown in the diagram. <div data-bbox="762 1615 1358 1839" style="text-align: center;"> </div>

NOTE No.	ITEM	SYMBOL	MEASUREMENT METHOD
20	Gate Pulse Switch Voltage	V_{GL} V_{GH}	(1) SW13 : b (2) Connect DC voltage to pin 15. (3) Observe pin 13 waveform of horizontal blanking period by lowering voltage added to pin 15 from 4.5V. (4) Measure pin 15 voltage when detection current stop flowing into pin 13. (V_{GL}) (5) Observe pin 13 waveform of vertical blanking period by lowering voltage added to pin 15 from 4.5V. (6) Measure pin 15 voltage when detection current starts to flow into pin 13. (V_{GH})
21	OSD ON Current	I_{ON}	(1) SW10A : ON, SW10B : OFF, SW12 : b (2) Input SECAM white color only chroma signal from TP10B. (3) Connect DC current to TP22 and decrease from 2 [V]. (4) Measure flowing current from TP22 when TP19 voltage changes from 5.5 [V] to 6.7 [V] (I_{ON}).
22	OSD OFF Current	I_{OFF}	(1) SW10A : ON, SW10B : OFF, SW12 : b (2) Input SECAM white color only chroma signal from TP10B. (3) Connect DC current to TP22 and decrease from 0 [V]. (4) Measure flowing current from TP22 when TP19 voltage changes from 6.7 [V] to 5.5 [V] (I_{OFF}).
23	OSD Output High Voltage	V_{OSDH}	(1) SW10A : ON, SW10B : OFF, SW12 : b (2) Input SECAM white color only chroma signal from TP10B. (3) Ground TP22. (4) Measure TP19 voltage.
24	OSD Output Low Voltage	V_{OSDL}	(1) SW10A : ON, SW10B : OFF, SW12 : b (2) Input SECAM white color only chroma signal from TP10B. (3) Ground TP23. (4) Measure TP19 voltage.
25	OSD Rise Time OSD Rise Time Transfer Time OSD Fall Time OSD Fall Time Transfer Time	t_R t_{RD} t_F t_{FD}	(1) SW10A : ON, SW10B : OFF, SW12 : b (2) Input SECAM white color only chroma signal from TP10B. (3) Input waveform shown in another diagram to TP22 and measure each value.

PULSE FOR MEASUREMENT OSD SECTION

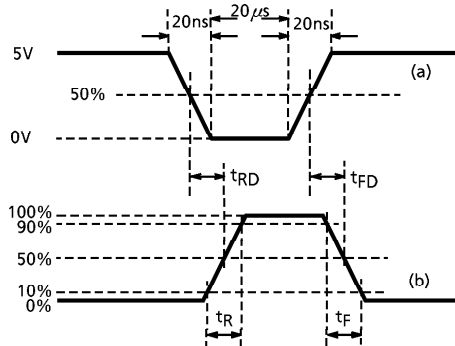

TEST CIRCUIT

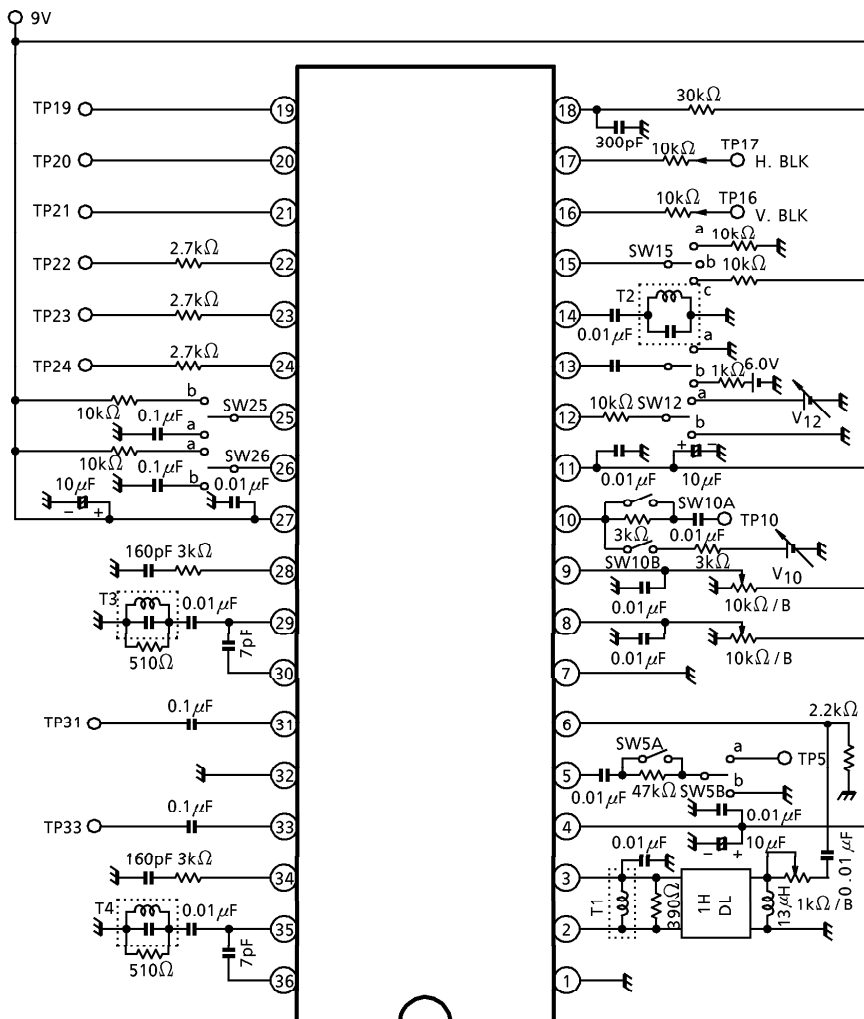

APPLICATION CIRCUIT

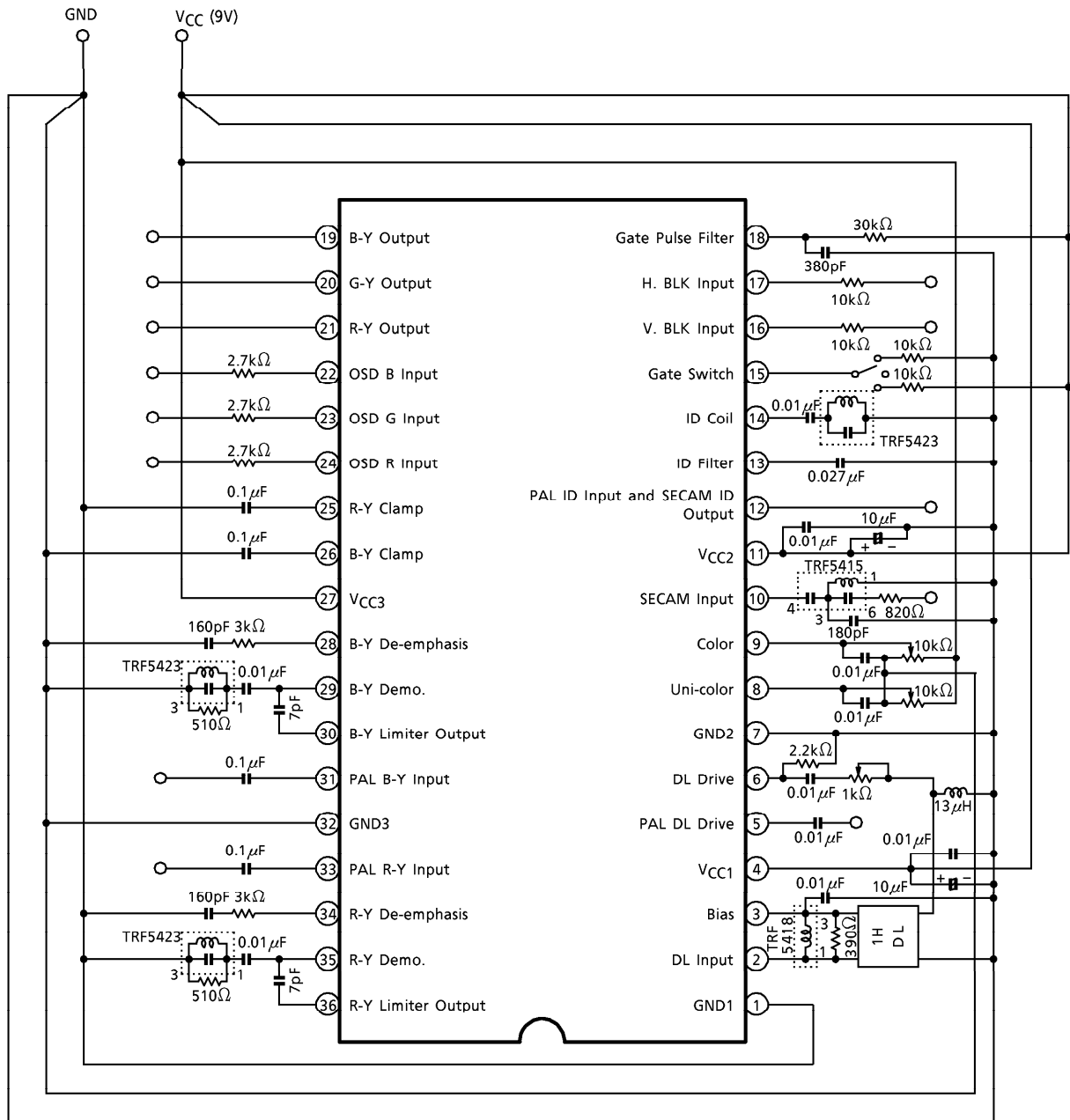

COIL DATA

- BELL filter

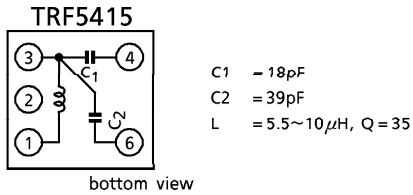

- Matching coil for 1H glass DL

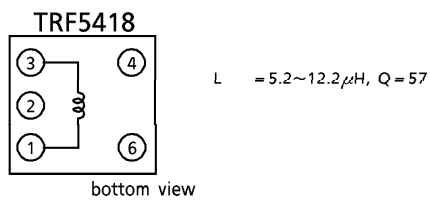

- SECAM ID, color difference demodulation coil

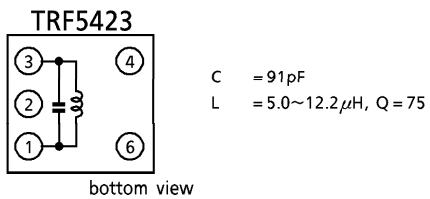

1H glass DL data

Center frequency : 4.433619MHz
 Passing loss : 10 ± 3dB
 3dB band width : ± 1.0MHz

EXAMPLE FOR CONNECTION WITH TA8690AN

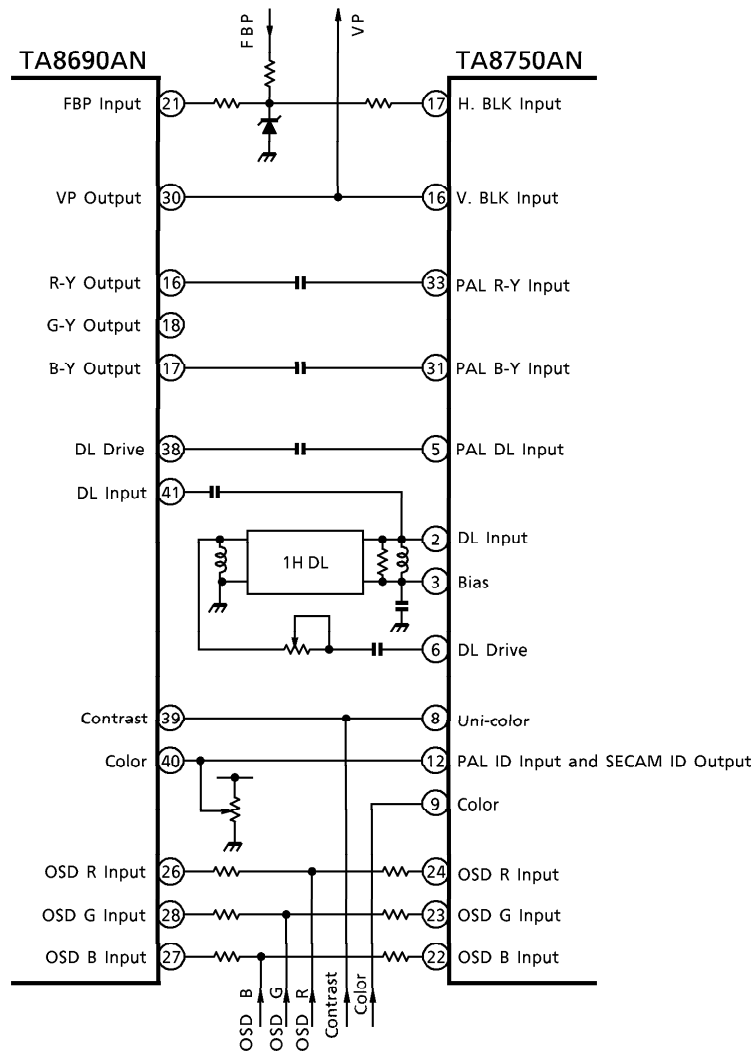

OUTLINE DRAWING
SDIP36-P-500-1.78

Unit : mm

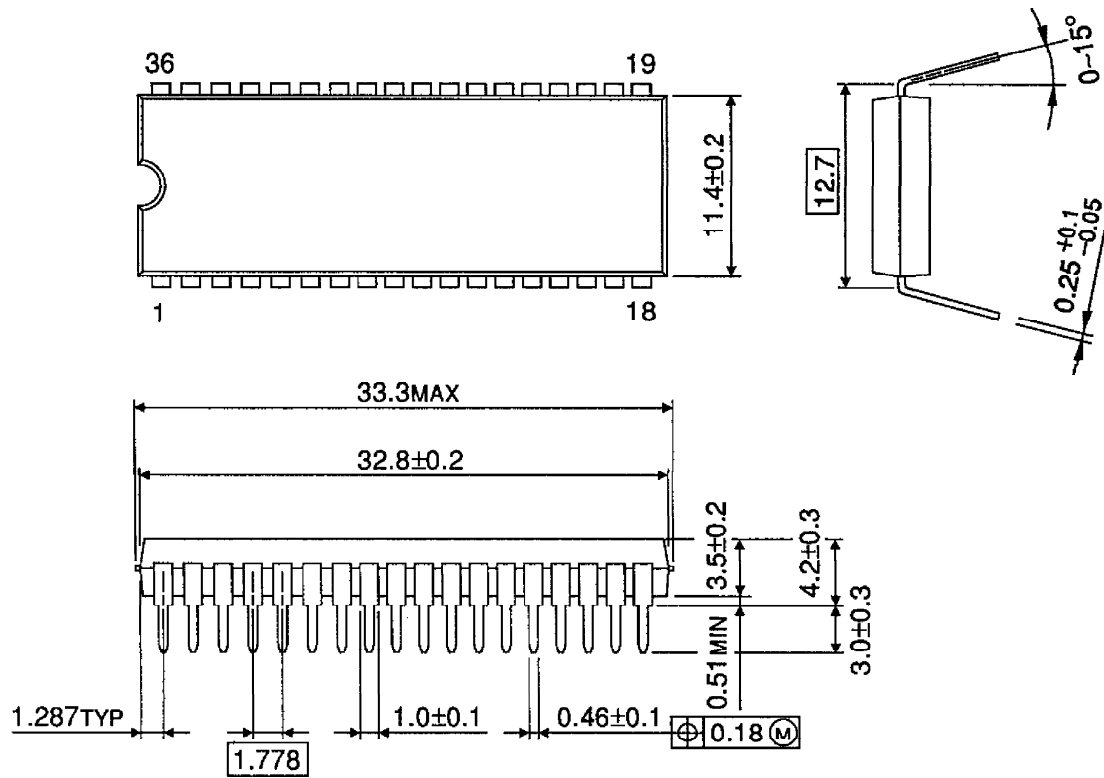

Weight : 2.98g (Typ.)