

FM STEREO MULTIPLEX DECODER

The KA2261 is a monolithic integrated circuit consisting of a phase locked loop FM stereo demodulator. It was designed for use in car stereos, cassette recorders and other equipment.

FEATURES

- A PLL is used for high multiplexing performance.
- Wide operating supply voltage range: $V_{CC} = 3V \sim 14V$
- Low quiescent circuit current ($I_{CCQ} = 8.5mA$, Typ).
- High SCA rejection ratio.
- High channel separation (45dB, Typ) and can be controlled by an external resistor.
- Built-in VCO disable and monaural muting circuits.
- Built-in stereo indicator lamp drive circuit.

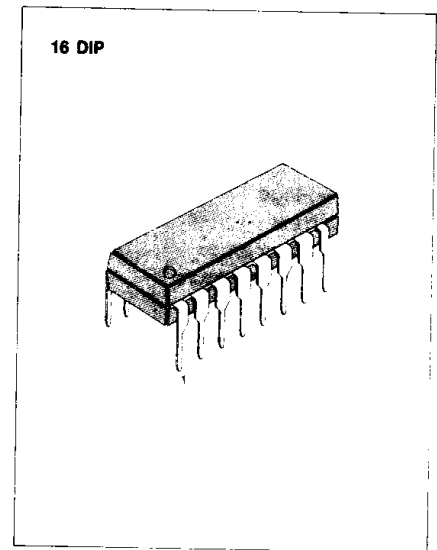

ORDERING INFORMATION

Device	Package	Operating Temperature
KA2261	16 DIP	-20°C ~ +70°C

BLOCK DIAGRAM

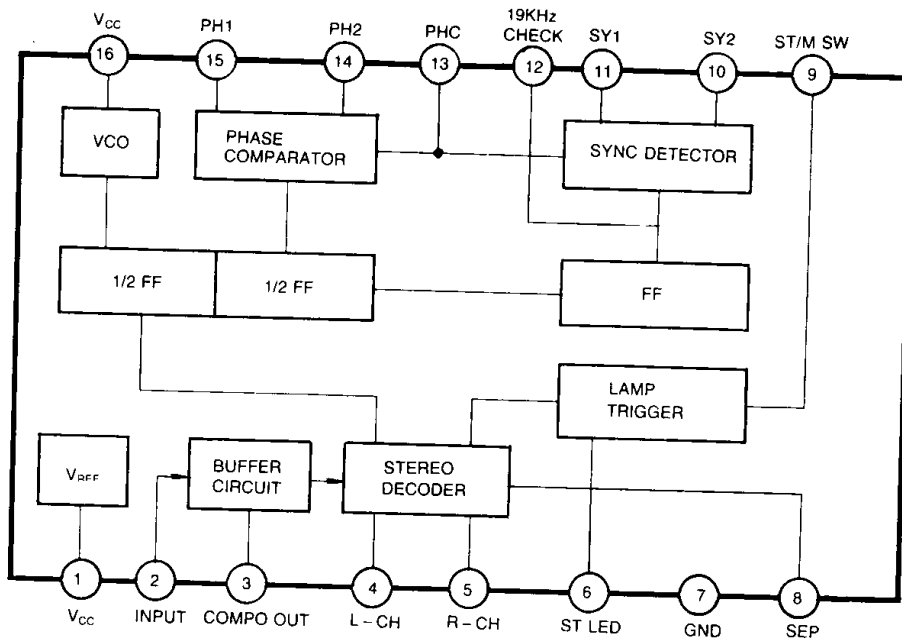

Fig. 1.

ABSOLUTE MAXIMUM RATINGS ($T_a = 25^\circ\text{C}$)

Characteristic	Symbol	Value	Unit
Supply Voltage	V_{CC}	16	V
Lamp Current	I_{LAMP}	40	mA
Power Dissipation	P_D	400	mW
Operating Temperature	T_{OPR}	-20 ~ +70	$^\circ\text{C}$
Storage Temperature	T_{STG}	-40 ~ +125	$^\circ\text{C}$

ELECTRICAL CHARACTERISTICS

($T_a = 25^\circ\text{C}$, $V_{CC} = 6\text{V}$, $f = 1\text{KHz}$, $R_L = 3.3\text{K}\Omega$, unless otherwise specified)

Characteristic	Symbol	Test Conditions	Min	Typ	Max	Unit
Quiescent Circuit Current	I_{CCQ}	$V_i = 0$		8.5	12	mA
Channel Separation	CS	$V_i = 100\text{mV}$, $L + R = 90\%$ $P = 10\%$, $f = 1\text{KHz}$	35	45		dB
Total Harmonic Distortion	Mono	THD 1		0.2		%
	Stereo	THD 2		0.7		%
Output Voltage	V_o	$V_i = 100\text{mV}$, $f = 1\text{KHz}$	66	85	115	mV
Channel Balance	CB	$V_i = 100\text{mV}$, $f = 1\text{KHz}$		0.5	1.5	dB
Lamp on Level	$V_{L(ON)}$	$L + R = 90\%$, $P = 10\%$		65		mV
Lamp Hysteresis	HY			3.5	6.0	dB
Maximum Input Level	$V_{I(MAX)}$	THD=2%		450		mV
SCA Rejection Ratio	SCA_{REJ}	$L + R = 90\%$, $P = 10\%$		70		dB
Signal to Noise Ratio	S/N	$V_i = 100\text{mV}$, $f = 1\text{KHz}$		75		dB
Carrier Leakage	V_{LKG}	$V_i = 100\text{mV}$, $L + R = 90\%$ $P = 10\%$		32		dB
Capture Range	CR	$V_i = 100\text{mV}$, $L + R = 90\%$ $P = 10\%$		± 3		%
Input Impedance	Z_i		15	20		$\text{K}\Omega$

TEST CIRCUIT

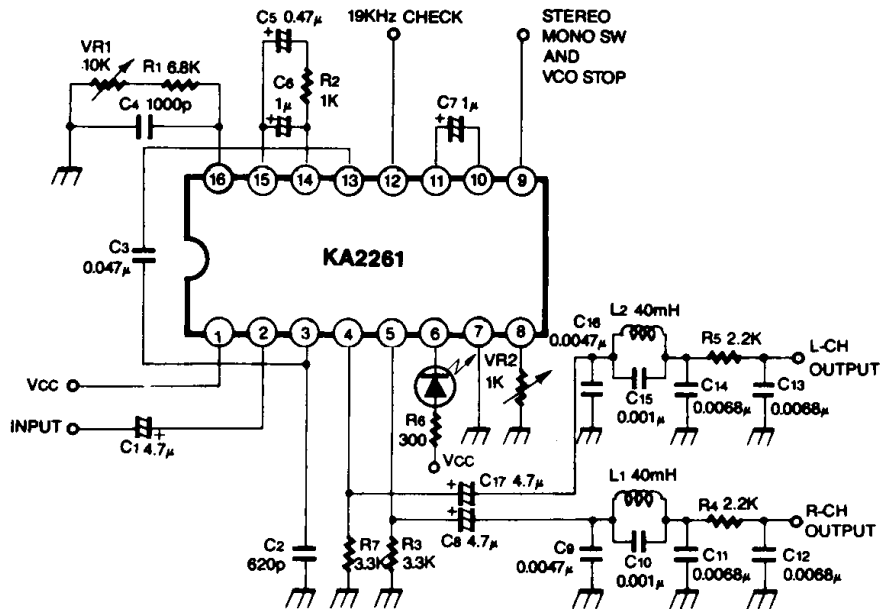
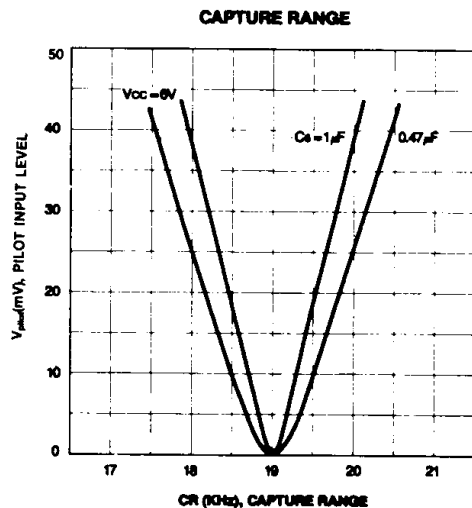
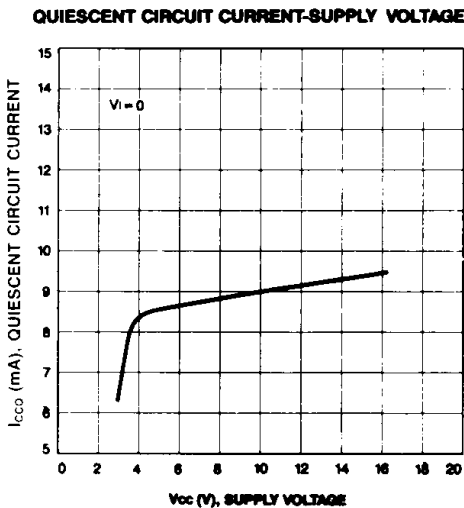
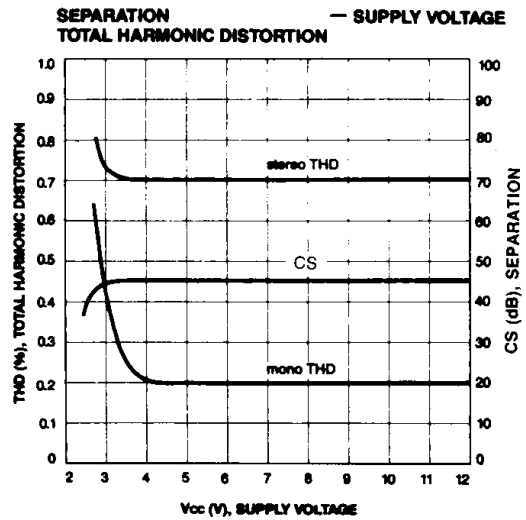
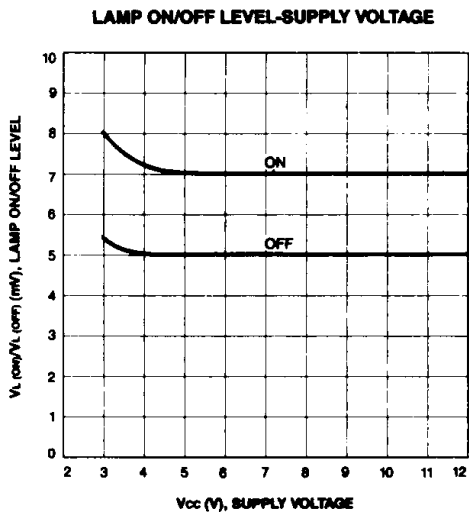
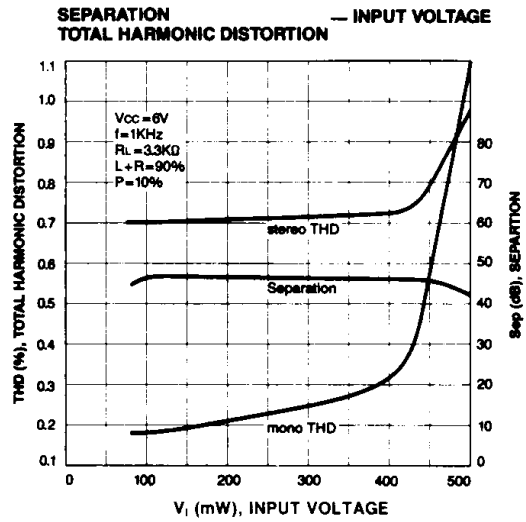
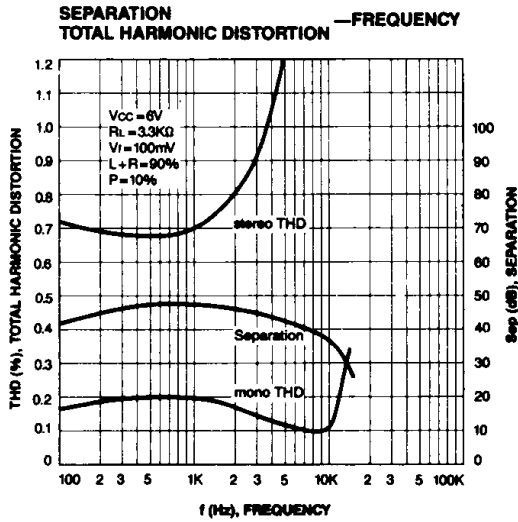

Fig. 2



APPLICATION INFORMATION

External Components (Refer to Test Circuit)

1. Input coupling capacitor (Pin 2)
The recommended value is $4.7\mu\text{F}$. If smaller values than $4.7\mu\text{F}$ are used, low frequency separation will worsen, and if larger values are used, the DC operating point will require time for stabilization.
2. Demodulator output (Pin 4, 5)
These components provide R and L channel output load circuits. The recommended circuits are follows:

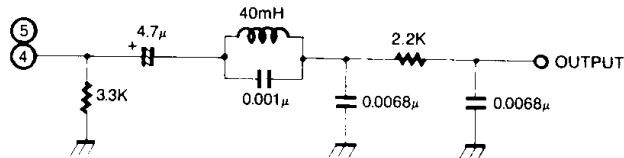

3. Separation control (Pin 8)
This component is a variable resistor used to adjust the out signal separation.
4. Low pass filter (Pins 10, 11)
This capacitor is used to filter the 19KHz signal detected by the phase comparator. The recommended value is $1\mu\text{F}$. If made too small, the lamp may light imprevoly when a large mono input signal or external noise is received, too large a capacitance value will take more time to switch between mono and stereo modes.
5. Preampifier output capacitor (Pins 3, 13)
This capacitor coupled preamplified with phase comparator. The recommended value is $0.047\mu\text{F}$.
6. Phase compensation capacitor (Pin 3, GND)
This capacitor is prepared in order to compensate the phase advanced.
7. Loop filter (Pins 14, 15)
This is the low pass filter for the PLL, which is determined the capture range. The recommended value as follows:
 $V_i \leq 250\text{mV}$ $C_{14-15} = 0.47\mu\text{F}$
 $V_i \geq 250\text{mV}$ $C_{14-15} = 1\mu\text{F}$
8. Control of Pin 9
Function of Pin 9 is a change-over of stereo/mono and VCO stopping.

SCHMATIC DIAGRAM of PIN 9 CONTROL

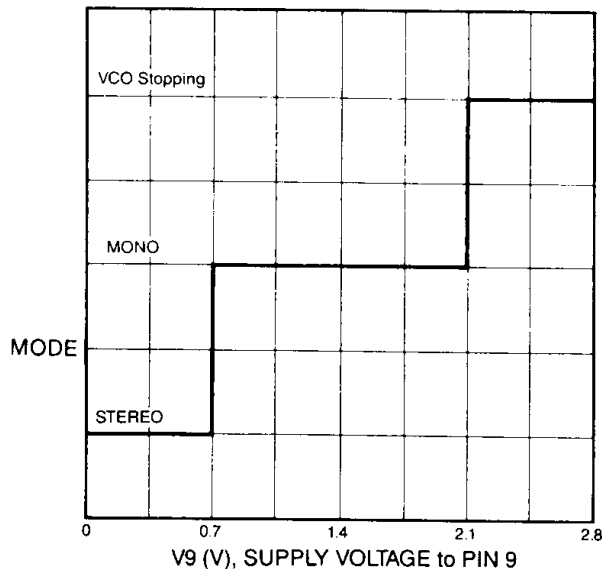

9. VCO network (Pin 16)
Since the VCO has a negative temperature coefficient, the RC network compensates by using a polyester film capacitor and a resistor.