

Silicon PNP Power Transistors

2SA1227 2SA1227A

DESCRIPTION

- With TO-3PFa package
- Complement to type 2SC2987/2987A
- High power dissipation

APPLICATIONS

- For use in audio frequency power amplifier applications

PINNING

PIN	DESCRIPTION
1	Base
2	Collector
3	Emitter

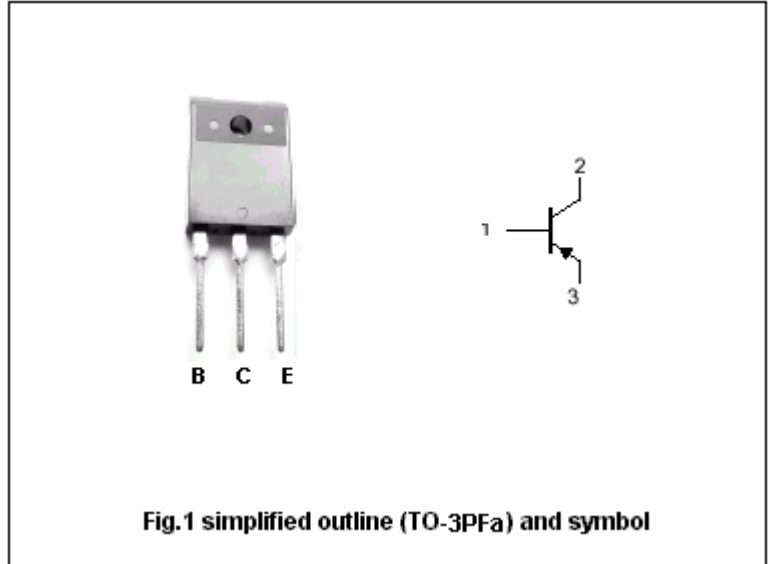

Absolute maximum ratings(Ta=25)

SYMBOL	PARAMETER	CONDITIONS	VALUE	UNIT
V _{CBO}	Collector-base voltage	2SA1227	-140	V
		2SA1227A	-160	
V _{CEO}	Collector-emitter voltage	2SA1227	-140	V
		2SA1227A	-160	
V _{EBO}	Emitter-base voltage	Open collector	-5	V
I _C	Collector current		-12	A
I _{CM}	Collector current-peak		-20	A
P _T	Total power dissipation	T _C =25	120	W
T _j	Junction temperature		150	
T _{stg}	Storage temperature		-55~150	

Silicon PNP Power Transistors

2SA1227 2SA1227A

CHARACTERISTICS

T_j=25 unless otherwise specified

SYMBOL	PARAMETER	CONDITIONS	MIN	TYP.	MAX	UNIT
V _{CEsat}	Collector-emitter saturation voltage	I _C =-5A ; I _B =-0.5A		-0.8	-1.5	V
V _{BEsat}	Base-emitter saturation voltage	I _C =-5A ; I _B =-0.5A		-1.5	-2.0	V
I _{CBO}	Collector cut-off current	V _{CB} =-140V; I _E =0			-50	μ A
I _{EBO}	Emitter cut-off current	V _{EB} =-3V; I _C =0			-50	μ A
h _{FE-1}	DC current gain	I _C =-2A ; V _{CE} =-5V	60		320	
h _{FE-2}	DC current gain	I _C =-5A ; V _{CE} =-5V	40			
C _{OB}	Output capacitance	I _E =0 ; V _{CB} =-10V; f=1MHz		280		pF
f _T	Transition frequency	I _C =-1A ; V _{CE} =-5V		60		MHz

◆ h_{FE-1} classifications

R	Q	P
60-120	100-200	160-320

Silicon PNP Power Transistors

2SA1227 2SA1227A

PACKAGE OUTLINE

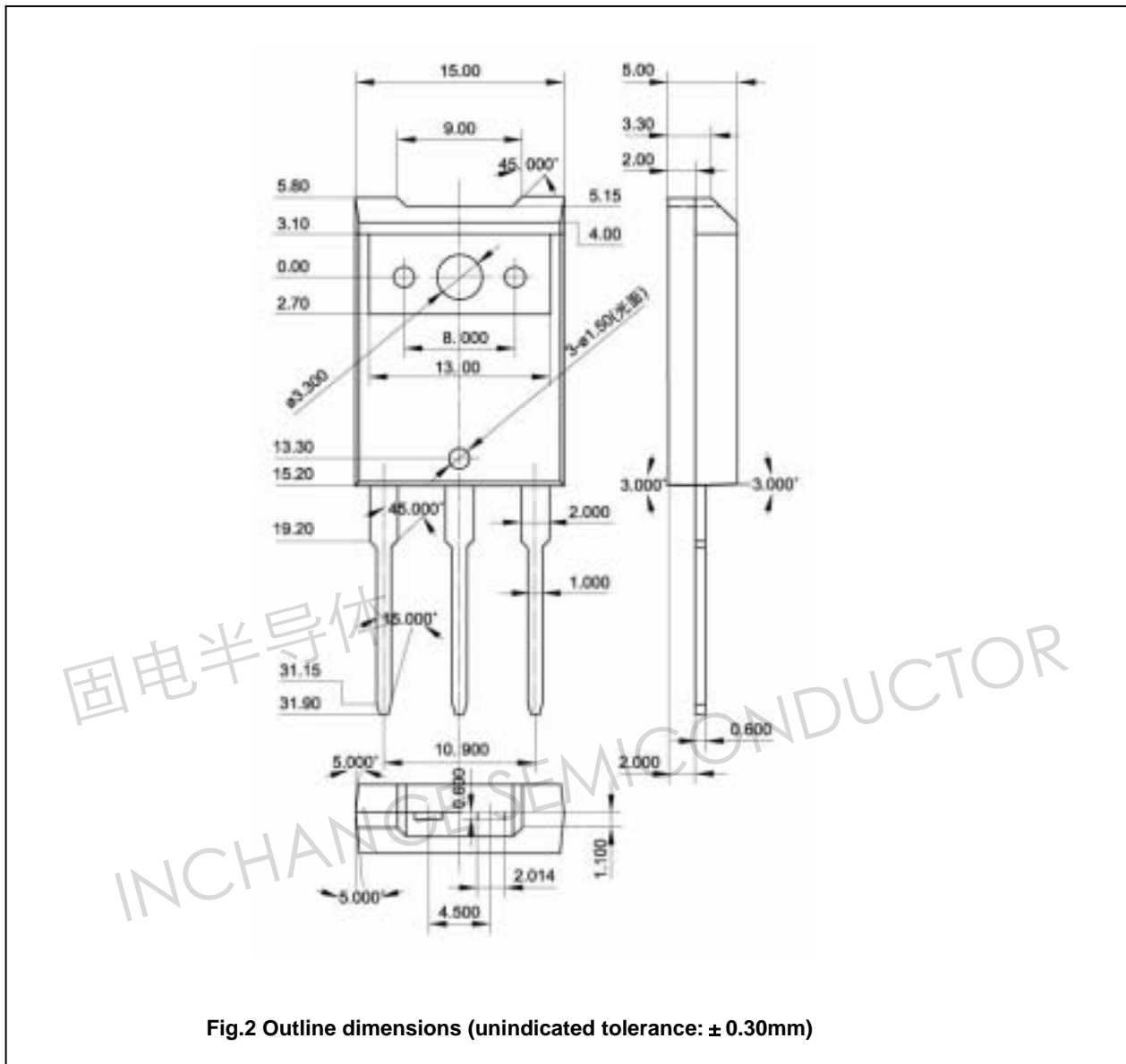

Fig.2 Outline dimensions (unindicated tolerance: ± 0.30mm)