

TO-220 Plastic Package

**BDX53, BDX53A, BDX53B, BDX53C
BDX54, BDX54A, BDX54B, BDX54C**

BDX53, 53A, 53B, 53C NPN PLASTIC POWER TRANSISTORS
BDX54, 54A, 54B, 54C PNP PLASTIC POWER TRANSISTORS
Power *Darlington* for Linear and Switching Applications

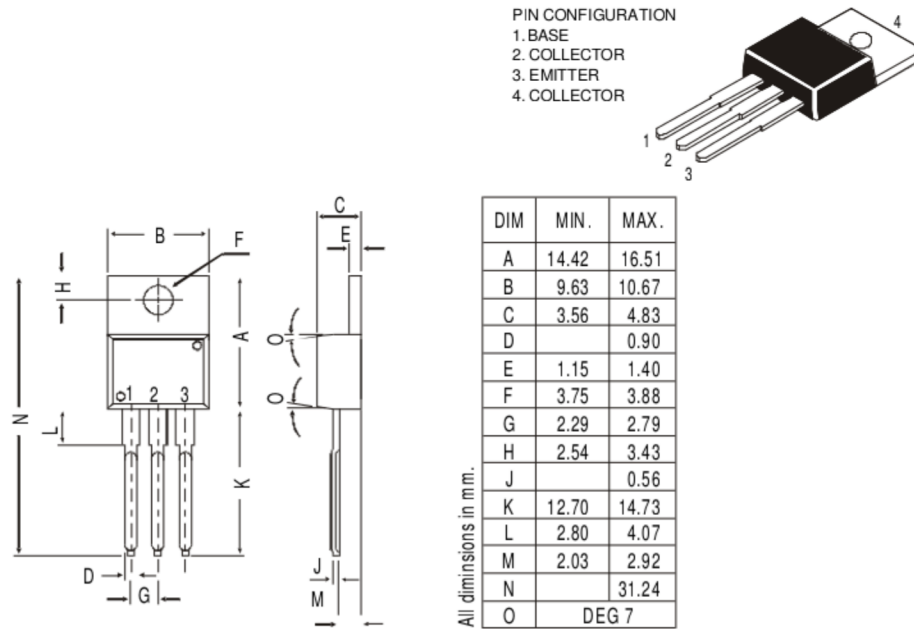

ABSOLUTE MAXIMUM RATINGS

		53	53A	53B	53C	
		54	54A	54B	54C	
Collector-base voltage (open emitter)	V_{CBO}	max. 45	60	80	100	V
Collector-emitter voltage (open base)	V_{CEO}	max. 45	60	80	100	V
Collector current	I_C	max.		8.0		A
Total power dissipation up to $T_C = 25^\circ\text{C}$	P_{tot}	max.		60		W
Junction temperature	T_j	max.		150		$^\circ\text{C}$
Collector-emitter saturation voltage $I_C = 3\text{ A}; I_B = 12\text{ mA}$	V_{CEsat}	max.		2.0		V
D.C. current gain $I_C = 3\text{ A}; V_{CE} = 3\text{ V}$	h_{FE}	min.		750		

RATINGS (at $T_A=25^\circ\text{C}$ unless otherwise specified)

		53	53A	53B	53C	
		54	54A	54B	54C	
Collector-base voltage (open emitter)	V_{CBO}	max. 45	60	80	100	V
Collector-emitter voltage (open base)	V_{CEO}	max. 45	60	80	100	V
Emitter-base voltage (open collector)	V_{EBO}	max.		5.0		V

BDX53, BDX53A, BDX53B, BDX53C
BDX54, BDX54A, BDX54B, BDX54C

Collector current	I_C	max.	8.0	A
Collector current (Peak value)	I_{CM}	max.	12	A
Base current	I_B	max.	0.2	A
Total power dissipation upto $T_C=25^\circ\text{C}$	P_{tot}	max.	60	W
Derate above 25°C		max.	0.48	W/°C
Junction temperature	T_j	max.	150	°C
Storage temperature	T_{stg}		-65 to +150	°C

THERMAL RESISTANCE

From junction to case	$R_{th\ j-c}$		2.08	°C/W
From junction to ambient	$R_{th\ j-a}$		7.0	°C/W

CHARACTERISTICS

$T_{amb} = 25^\circ\text{C}$ unless otherwise specified

		53	53A	53B	53C	
		54	54A	54B	54C	
Collector cutoff current						
$I_B = 0; V_{CB} = 45\text{ V}$	I_{CBO}	max. 0.2	-	-	-	mA
$I_B = 0; V_{CB} = 60\text{ V}$	I_{CBO}	max. -	0.2	-	-	mA
$I_B = 0; V_{CB} = 80\text{ V}$	I_{CBO}	max. -	-	0.2	-	mA
$I_B = 0; V_{CB} = 100\text{ V}$	I_{CBO}	max. -	-	-	0.2	mA
$I_B = 0; V_{CE} = 22\text{ V}$	I_{CEO}	max. 0.5	-	-	-	mA
$I_B = 0; V_{CE} = 30\text{ V}$	I_{CEO}	max. -	0.5	-	-	mA
$I_B = 0; V_{CE} = 40\text{ V}$	I_{CEO}	max. -	-	0.5	-	mA
$I_B = 0; V_{CE} = 50\text{ V}$	I_{CEO}	max. -	-	-	0.5	mA
Emitter cut-off current						
$I_C = 0; V_{EB} = 5\text{ V}$	I_{EBO}	max.	2.0			mA
Breakdown voltages						
$I_C = 100\text{ mA}; I_B = 0$	$V_{CEO(sus)}^*$	min. 45	60	80	100	V
$I_C = 1\text{ mA}; I_E = 0$	V_{CBO}	min. 45	60	80	100	V
$I_E = 1\text{ mA}; I_C = 0$	V_{EBO}	min.	5.0			V
Saturation voltages						
$I_C = 3\text{ A}; I_B = 12\text{ mA}$	V_{CEsat}^*	max.	2.0			V
	V_{BEsat}^*	max.	2.5			V
D.C. current gain						
$I_C = 3\text{ A}; V_{CE} = 3\text{ V}$	h_{FE}^*	min.	750			
Small signal current gain						
$I_C = 3\text{ A}; V_{CE} = 4\text{ V}; f = 1.0\text{ MHz}$	$ h_{fe} $	min.	4.0			
Output capacitance $f = 1.0\text{ MHz}$						
$I_E = 0; V_{CB} = 10\text{ V}$	NPN C_o	max.	300			pF
	PNP C_o	max.	200			pF
Parallel-diode forward voltage						
$I_F = 3\text{ A}$	V_F	max.	2.5			V
$I_F = 8\text{ A}$	V_F	typ.	2.5			V

* Pulse test: pulse width $\leq 300\ \mu\text{s}$; duty cycle $\leq 2\%$

Customer Notes

Disclaimer

The product information and the selection guides facilitate selection of the CDIL's Discrete Semiconductor Device(s) best suited for application in your product(s) as per your requirement. It is recommended that you completely review our Data Sheet(s) so as to confirm that the Device(s) meet functionality parameters for your application. The information furnished on the CDIL Web Site/ CD is believed to be accurate and reliable. CDIL however, does not assume responsibility for inaccuracies or incomplete information. Furthermore, CDIL does not assume liability whatsoever, arising out of the application or use of any CDIL product; neither does it convey any license under its patent rights nor rights of others. These products are not designed for use in life saving/support appliances or systems. CDIL customers selling these products (either as individual Discrete Semiconductor Devices or incorporated in their end products), in any life saving/support appliances or systems or applications do so at their own risk and CDIL will not be responsible for any damages resulting from such sale(s).

CDIL strives for continuous improvement and reserves the right to change the specifications of its products without prior notice.



CDIL is a registered Trademark of
Continental Device India Limited

C-120 Naraina Industrial Area, New Delhi 110 028, India.
Telephone + 91-11-2579 6150, 5141 1112 Fax + 91-11-2579 5290, 5141 1119
email@cdil.com www.cdilsemi.com