

TC9132P

T-77-11

TC9132P REMOTE CONTROL TRANSMITTER

TC9132P is C-MOS LSI developed for remote control transmission.

This unit may make up a 32-function remote control system by using TC9133P or TC9134P, C-MOS LSI, in pairs.

- Designed for a wide range of operating supply voltage and permits operation at low voltage, (2.2V ~ 5.0V).
- C-MOS configuration makes possible extremely low power consumption.
- An oscillator may be composed simply by making connection of LC or ceramic oscillator owing to the built-in oscillation circuit.
- Built-in 3-bit code allows 7 kinds of equipment to be operated.
- Provided with indicator output for transmission.

MAXIMUM RATINGS (Ta = 25°C)

CHARACTERISTIC	SYMBOL	RATING	UNIT
Supply Voltage	V _{DD}	0 ~ +5	V
Input/Output Voltage	V _{IN} , V _{OUT}	V _{SS} -0.3 ~ V _{DD} +0.3	V
IRout Current	I-IR _{OUT}	-1.0	mA
LEDout Current	I _{LED}	-1.0	mA
Power Dissipation	P _D	200	mW
Operating Temperature	T _{opr}	-20 ~ 65	°C
Storage Temperature	T _{stg}	-55 ~ 125	°C

Unit in mm

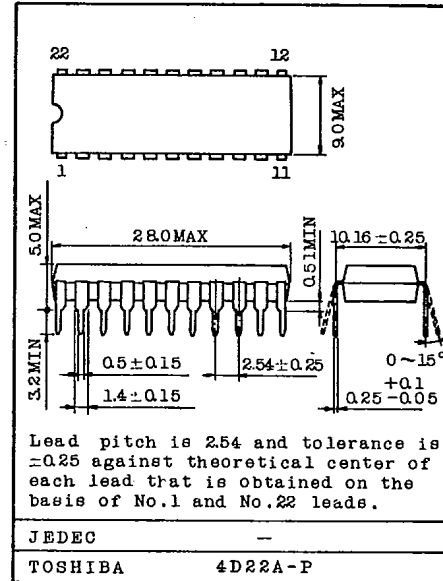

PIN CONNECTIONS

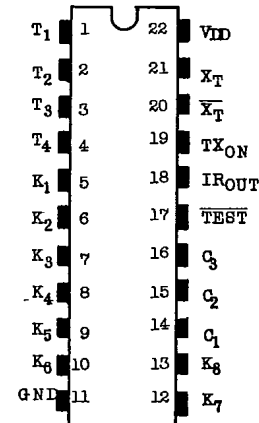

TOSHIBA

TC9132P

T-77-11

ELECTRICAL CHARACTERISTICS (Unless otherwise specified, $V_{DD}=3.0V$, $T_a=25^{\circ}C$.)

CHARACTERISTIC	SYMBOL	TEST CIRCUIT	TEST CONDITIONS	MIN.	TYP.	MAX.	UNIT
*Operating Supply Voltage	V_{DD}	-	All functional operations	2.2	3.0	5.0	V
Supply Current	Operating	I_{DD}	Key ON, Output without load	-	0.3	1.0	mA
	Quiescent	I_{DS}	All keys OFF. Stop of OSC	-	10	20	μA
Timing Output Current $T1 \sim T4$	"H" Level	I_{OH}	$V_{DD}=3.0V$, $V_{OH}=2.0V$	-100	-	-	μA
	"L" Level	I_{OL}	$V_{DD}=3.0V$, $V_{OL}=1.0V$	20	-	-	
IR Output Current	"H" Level	I_{OH}	$V_{DD}=3.0V$, $V_{OH}=2.0V$	-20	-	-	μA
	"L" Level	I_{OL}	$V_{DD}=3.0V$, $V_{OL}=1.0V$	100	-	-	
Tx Indicator Output Current	"H" Level	I_{OH}	$V_{DD}=3.0V$, $V_{OH}=2.0V$	-20	-	-	μA
	"L" Level	I_{OL}	$V_{DD}=3.0V$, $V_{OL}=1.0V$	100	-	-	
Key Input Current $K1 \sim K8$	"H" Level	I_{IH}	$V_{DD}=3.0V$, $V_{IN}=3.0V$	20	50	150	μA
	"L" Level	I_{IL}	$V_{DD}=3.0V$, $V_{IN}=0V$	-	-	-10	
Code Input Current $C1 \sim C3$	"H" Level	I_{IH}	$V_{DD}=3.0V$, $V_{IN}=3.0V$	-	-	1	μA
	"L" Level	I_{IL}	$V_{DD}=3.0V$, $V_{IN}=0V$	-	-	-1	
OSC feedback Resistance	R_f	-	-	-	2	-	$M\Omega$
*OSC Oscillatable Frequency	f_{osc}	-	-	-	455	600	kHz

* $T_a = -20 \sim 60^{\circ}C$

TC9132P

T-77-11

BLOCK DIAGRAM

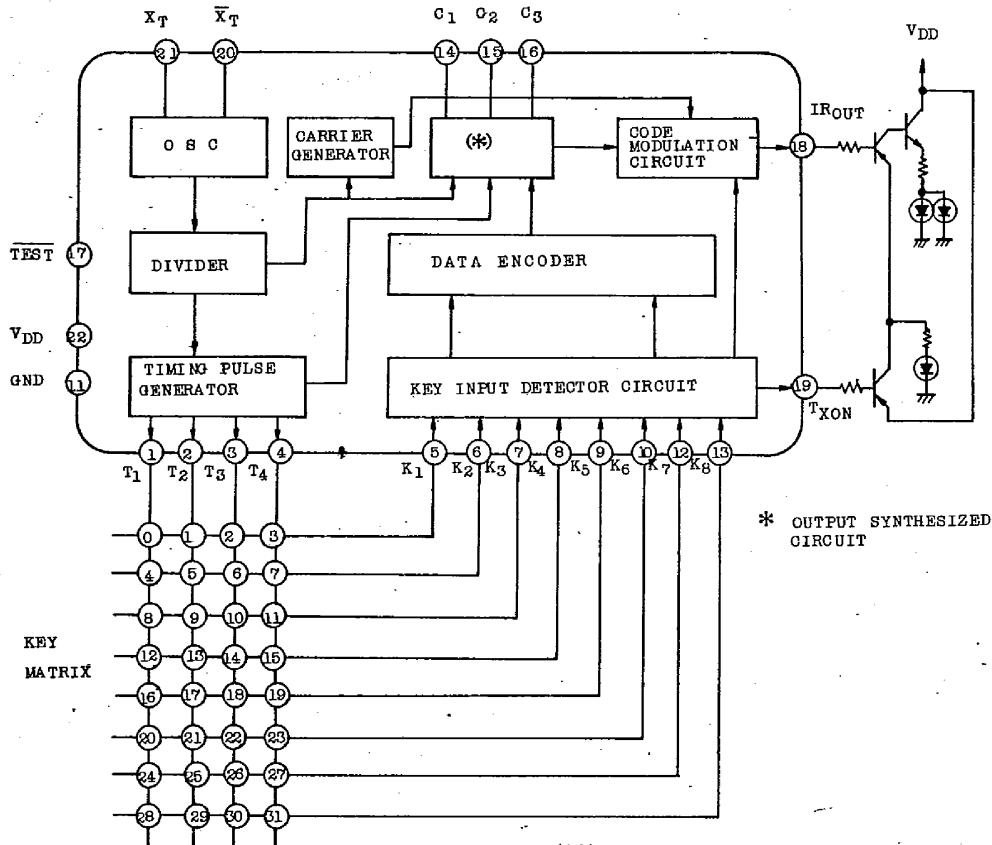

* OUTPUT SYNTHESIZED CIRCUIT

(**) Timing Output Signal
 (***) Indicator output in transmission

PIN DESCRIPTION

PIN NO.	SYMBOL	PIN NAME	DESCRIPTION OF FUNCTION AND OPERATION
1 ~ 4	T1 ~ T4	(**)	Timing digital output for key matrix.
5 ~ 10 12, 13	K1 ~ K8	Key input	Key input for key matrix. 32 instructions can be executed by T1 ~ T4 × K1 ~ K8.
14 ~ 16	C1 ~ C3	Code bit input	Code bit input. The unit may be available for 7 kinds of equipment because it is an input for code agreement between transmitting and receiving sides.
17	TEST	Test terminal	Usually set to "H" level.
18	IROUT	Transmitting output	Transmitting signal output. Modulated by carrier wave of 38 kHz taking 16 bits for 1 cycle.
19	TXON	(***)	Usually at "H" level, but changed to "L" level at time of transmission of signal.
20, 21	X _T , X _T ⁻	Oscillator terminal	Terminal for oscillator. A ceramic oscillator of 455kHz or the like is used.

TOSHIBA

TC9132P

T-77-11

FUNCTIONAL DESCRIPTION

1. OSCILLATION CIRCUIT

Since TC9132P contains self-bias type amplifier by use of C-MOS inverter, it can make up an oscillator circuit by making connection of LC or ceramic oscillator.

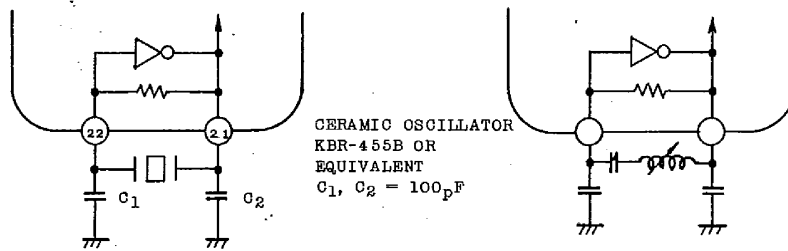

The carrier wave of transmit signal may be set to 38 kHz by using 455 kHz as standard oscillation frequency. It is possible to stop the oscillator actuation except for key operating time for reducing power consumption.

2. INPUT KEY

32 instructions may be input by 8×4 matrix based on key inputs $K_1 \sim K_8$ and timing signal $T_1 \sim T_4$. A chattering preventive circuit is built in the key input, being designed to reject chattering of less than about 10 msec.

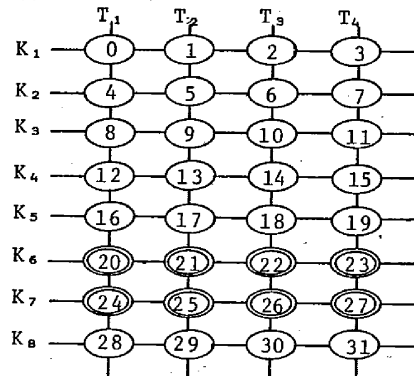

Key Matrix

- : Single-shot key - 1 pulse output
- : Continuous key - Output with it pressed.

TC9132P

T-77-11

3. DATA CODES

32 instructions are executed by 5-bit codes (A ~ E).

KEY NO.	DATA						KEY NO.	DATA					
	A	B	C	D	E			A	B	C	D	E	
0	0	0	0	0	0	Single-shot key	16	0	0	0	0	1	Single shot key
1	1	0	0	0	0	"	17	1	0	0	0	1	"
2	0	1	0	0	0	"	18	0	1	0	0	1	"
3	1	1	0	0	0	"	19	1	1	0	0	1	"
4	0	0	1	0	0	"	20	0	0	1	0	1	Continuous key
5	1	0	1	0	0	"	21	1	0	1	0	1	"
6	0	1	1	0	0	"	22	0	1	1	0	1	"
7	1	1	1	0	0	"	23	1	1	1	0	1	"
8	0	0	0	1	0	"	24	0	0	0	1	1	"
9	1	1	0	1	0	"	25	1	0	0	1	1	"
10	0	1	0	1	0	"	26	0	1	0	1	1	"
11	1	1	0	1	0	"	27	1	1	0	1	1	"
12	0	0	1	1	0	"	28	0	0	1	1	1	Single-shot key
13	1	0	1	1	0	"	29	1	0	1	1	1	"
14	0	1	1	1	0	"	30	0	1	1	1	1	"
15	1	1	1	1	1	"	31	1	1	1	1	1	"

4. CODE BITS (C₁, C₂, C₃)

In addition to data bits, this unit has 3-bit code bits and may be used for 7 kinds of equipment by code agreement with the receiving side.

	Code Bits		
	C ₁	C ₂	C ₃
	*		
1	1	0	0
2	0	1	0
3	1	1	0
4	0	0	1
5	1	0	1
6	0	1	1
7	1	1	1

* 000 code cannot be used.

TC9132P

T-77-11

5. TRANSMITTING WAVEFORM

5-1) Basic transmitting waveform

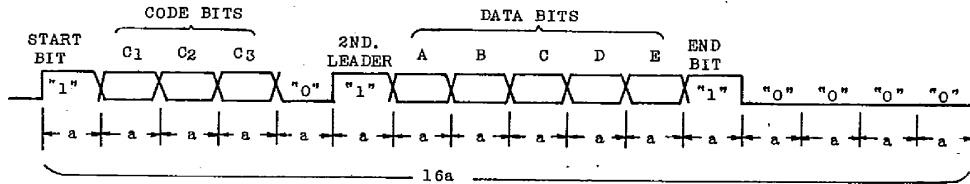

The basic transmitting waveform is 16-bit serial data, and is configured as follows: The time of each bit, a , is determined by oscillation frequency based on X_T and \bar{X}_T as mentioned below.

$$a = 1/f_x \times 1024 \text{ (sec)}$$

5-2) Single-shot signal

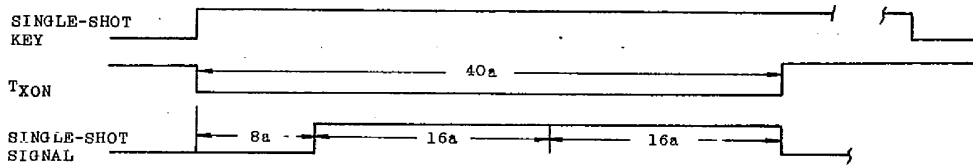

When any one of single-shot signal keys is pressed, the basic waveform of 5-1) is transmitted in 2 cycles, and the transmitting output ends.

5-3) Continuous signal

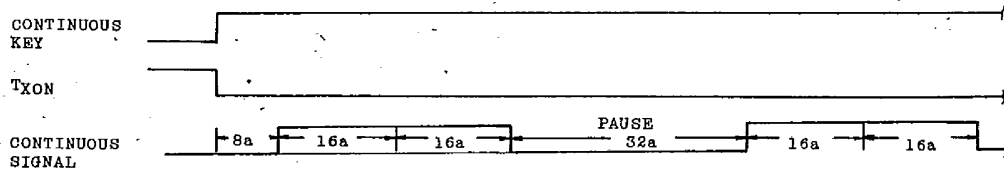

Basic waveform repeats output of 2 cycles - pause ("L" level) 2 cycles - while any one of continuous signal keys is being pressed.

TC9132P

T-77-11

5-4) Carrier wave

For transmission, the single-shot or continuous signal is output after the carrier wave is pulse-modulated. The frequency f_c of carrier wave is determined by the oscillation frequency f_x based on X_T and \bar{X}_T .

$$f_c = \frac{f_x}{12} \text{ (Hz)}$$

For example, in case where single-shot signal is "18" and code is 010, the carrier wave is as follows:

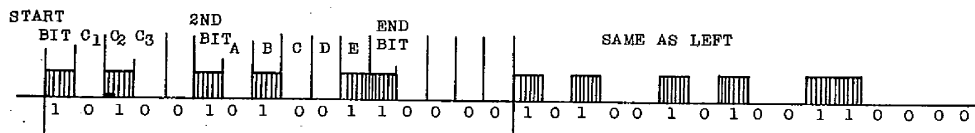

TC9132P

T-77-11

CIRCUIT APPLICATIONS

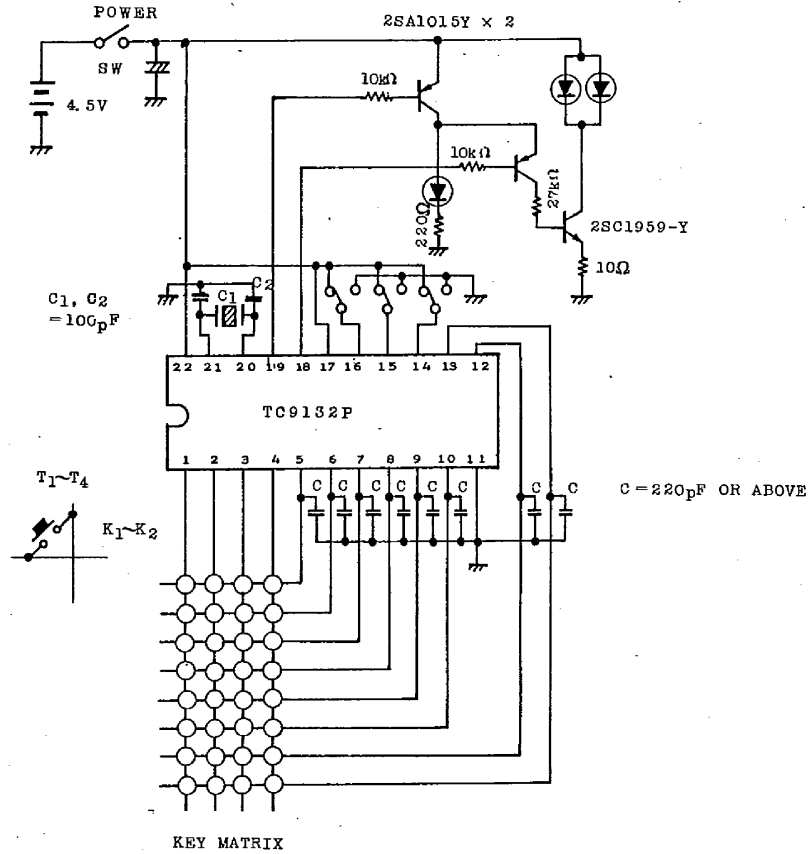

AUDIO DIGITAL IC

TC9132P

T-77-11

PRECAUTIONS ON APPLIED CIRCUIT

1. MULTIPLE PRESS PROHIBIT OF KEY

For multiple press of key, TC9132P makes it possible not to transmit output. TXON terminal is usually at "H" level, but it is changed to "L" level when there is key input; it maintains "L" level until the transmitting output ends. However, it is so designed as not to become "L" level, when 2 keys or more is input.

It is possible to configure multiple press prohibit circuit by producing output circuit as shown in the following figure utilizing this property.

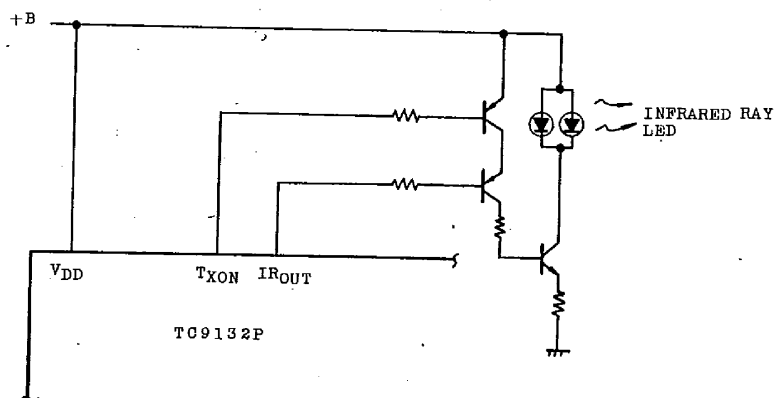

2. MALFUNCTION PROHIBIT OF KEY INPUT

The key input is of extremely high impedance; therefore, if wiring of key input line is long, there may be malfunction at float capacity between wires. It is recommended that capacitors be connected to K₁ ~ K₈.

TC9132P

T-77-11

USE A CAPACITOR
OF 220_pF OR OVER
IN CAPACITY.

