



SANYO Semiconductors

DATA SHEET

LA7210 — Monolithic Linear IC VCR Sync Detection Circuit

Overview

The LA7210 is a sync detection IC for acquiring optimal reception conditions in tuning systems for VCRs and similar products. This IC can implement an adjustment-free system with high detection precision using a ceramic oscillator VCO and a PLL-based horizontal sync detection circuit. In addition to use in tuning systems, this IC is also optimal for its support for the new German FTZ.

Functions

- Sync separator
- VCO (32fH)
- AFC
- Sync detection comparator

Features

- Ceramic oscillator adopted for adjustment-free manufacturing
- Package: SIF10
- Output format: Emitter follower

Specifications

Maximum Ratings at Ta = 25°C

Parameter	Symbol	Conditions	Ratings	Unit
Maximum supply voltage	V _{CC} max		14.0	V
Allowable power dissipation	Pd max	Ta ≤ 75°C	200	mW
Operating temperature	Topr		-15 to +75	°C
Storage temperature	Tstg		-40 to +125	°C

Operating Conditions at Ta = 25°C

Parameter	Symbol	Conditions	Ratings	Unit
Recommended supply voltage	V _{CC}		9.0 to 12.0	V
Operating supply voltage range	V _{CC} op		7.0 to 13.0	V

■ Any and all SANYO Semiconductor products described or contained herein do not have specifications that can handle applications that require extremely high levels of reliability, such as life-support systems, aircraft's control systems, or other applications whose failure can be reasonably expected to result in serious physical and/or material damage. Consult with your SANYO Semiconductor representative nearest you before using any SANYO Semiconductor products described or contained herein in such applications.

■ SANYO Semiconductor assumes no responsibility for equipment failures that result from using products at values that exceed, even momentarily, rated values (such as maximum ratings, operating condition ranges, or other parameters) listed in products specifications of any and all SANYO Semiconductor products described or contained herein.

SANYO Semiconductor Co., Ltd.

TOKYO OFFICE Tokyo Bldg., 1-10, 1 Chome, Ueno, Taito-ku, TOKYO, 110-8534 JAPAN

LA7210

Electrical Characteristics at $T_a = 25^\circ\text{C}$, $V_{CC} = 9\text{V}$

Parameter	Symbol	Conditions						Ratings			Unit
		SW1	SW2	SW3	SW4	SW5		min	typ	max	
Current drain	I_{CC}	c	a	a	b	a	No load	5.0	7.2	9.4	mA
Free-running frequency	f_{OSC}	c	a	a	a	a	No input		501		kHz
Oscillator output voltage	V_{OSC}	c	a	a	a	a	No input		1.9		Vp-p
Comparator input voltage	V_{8H}	c	a	b	a	a	$V_{10} : H \rightarrow L$	5.8	6.0	6.2	V
	V_{8L}	c	a	b	a	a	$V_{10} : L \rightarrow H$	3.6	3.8	4.0	V
Comparator output voltage	V_{10H}	c	a	b	a	a	$V_8 = 3\text{V}$	7.0	8.0	8.5	V
	V_{10L}	c	a	b	a <td a	$V_8 = 6.5\text{V}$		0	0.1	V	
Sync separator current	I_6	c	b	a	a	a	$V_{10} : H \rightarrow L$	100	125	150	μA
Sync detection voltage	V_{80H}	a	a	a	a	a	$SG1 = 0\text{dB}$		7.5		V
	V_{80L}	a	a	a	a	a	$SG1 = -20\text{dB}$		0	0.1	V
AFC locking range	f_{6H}	b	a	a	a	a	$V_{10} : H \rightarrow L$		15.82		kHz
	f_{6L}	b	a	a	a	a	$V_{10} : H \rightarrow L$		15.25		kHz
Tuning discrimination input level	V_{6IN}	a	a	a	a	a	$V_{10} : H \rightarrow L$		-12		dB
Logic operation	L1	b	a	a	a	b			Note 1		
	L2	c	c	a	a	b			Note 2		
Pin 6 voltage	V_6	c	c	a	a	a			6.7		V

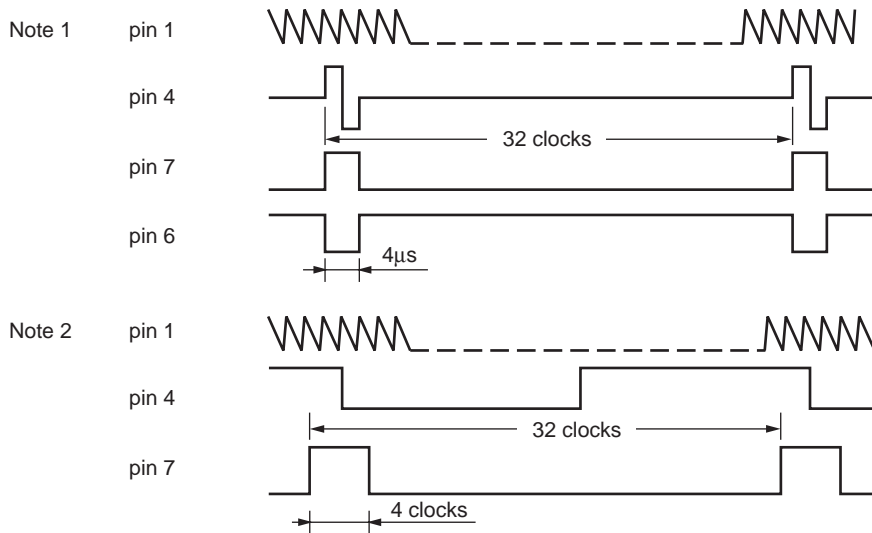

Package Dimensions

unit : mm (typ)

3043C

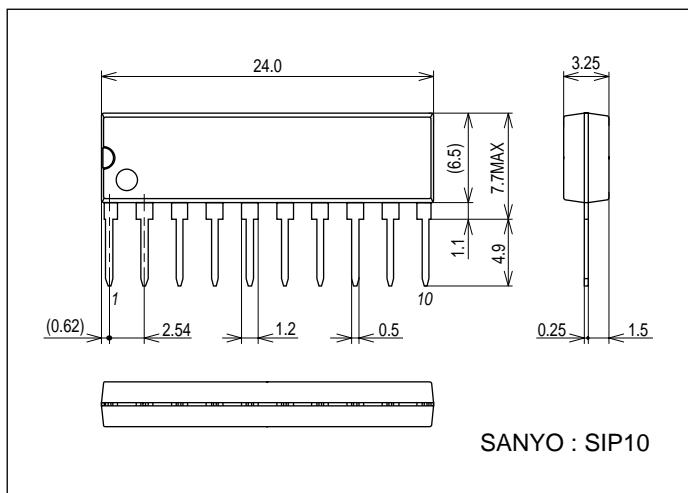

LA7210

Equivalent Circuit Block Diagram

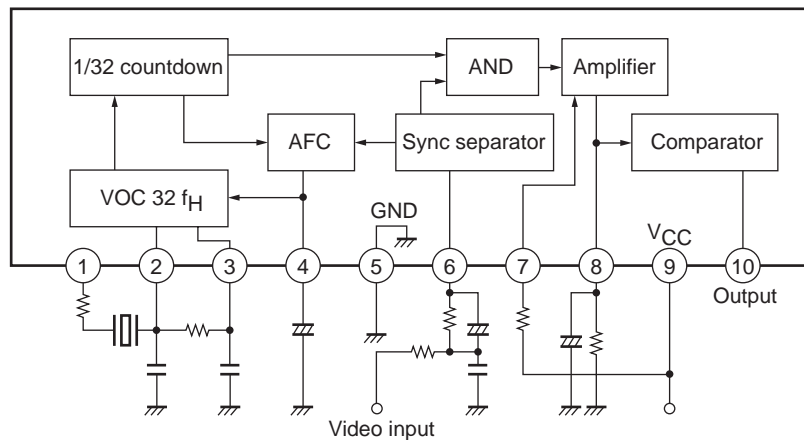

Test Circuit Diagram

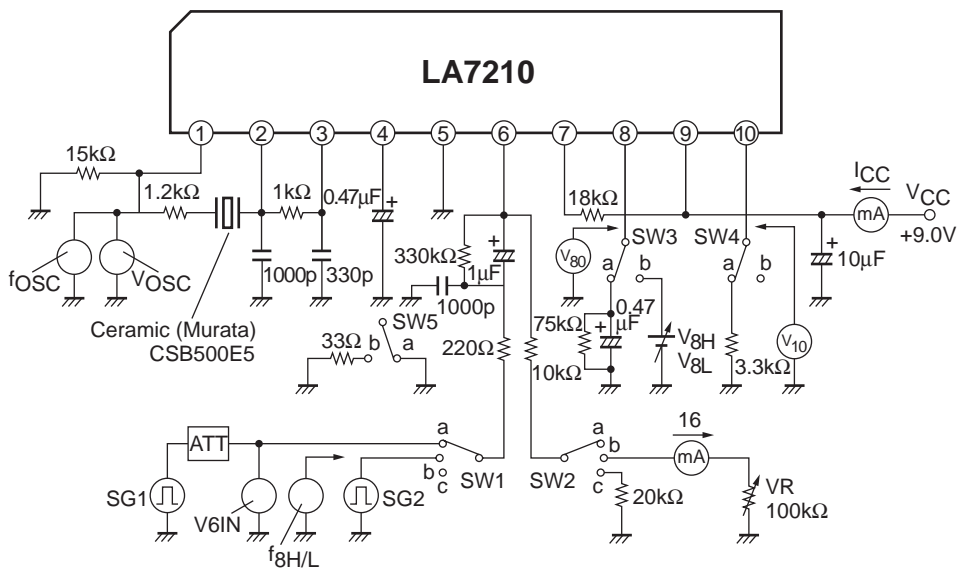

SG1 : Use a standard color bar (EBU) and take 0dB to be 1Vp-p.
 SG2 : Pulse generator (See the figure below.)

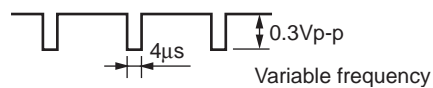

- Specifications of any and all SANYO Semiconductor products described or contained herein stipulate the performance, characteristics, and functions of the described products in the independent state, and are not guarantees of the performance, characteristics, and functions of the described products as mounted in the customer's products or equipment. To verify symptoms and states that cannot be evaluated in an independent device, the customer should always evaluate and test devices mounted in the customer's products or equipment.
- SANYO Semiconductor Co., Ltd. strives to supply high-quality high-reliability products. However, any and all semiconductor products fail with some probability. It is possible that these probabilistic failures could give rise to accidents or events that could endanger human lives, that could give rise to smoke or fire, or that could cause damage to other property. When designing equipment, adopt safety measures so that these kinds of accidents or events cannot occur. Such measures include but are not limited to protective circuits and error prevention circuits for safe design, redundant design, and structural design.
- In the event that any or all SANYO Semiconductor products (including technical data, services) described or contained herein are controlled under any of applicable local export control laws and regulations, such products must not be exported without obtaining the export license from the authorities concerned in accordance with the above law.
- No part of this publication may be reproduced or transmitted in any form or by any means, electronic or mechanical, including photocopying and recording, or any information storage or retrieval system, or otherwise, without the prior written permission of SANYO Semiconductor Co., Ltd.
- Any and all information described or contained herein are subject to change without notice due to product/technology improvement, etc. When designing equipment, refer to the "Delivery Specification" for the SANYO Semiconductor product that you intend to use.
- Information (including circuit diagrams and circuit parameters) herein is for example only; it is not guaranteed for volume production. SANYO Semiconductor believes information herein is accurate and reliable, but no guarantees are made or implied regarding its use or any infringements of intellectual property rights or other rights of third parties.

This catalog provides information as of November, 2006. Specifications and information herein are subject to change without notice.