

Test pattern generator

BA7004

The BA7004 is a test signal generator for VCRs that can be used to tune the receiving frequency of television tuners to the RF converter output frequency of VCRs.

When a TV is receiving a television broadcast through a VCR, the TV receiving frequency must match the RF converter output frequency of the VCR for the broadcast image to be displayed.

Particularly for UHF-band VCRs (PAL and SECAM), when an electronic tuner is used in the VCR, the RF converter is a multi-channel variable type, and electronic tuning is used in the television as well, it is extremely difficult to match the channel frequencies for the two pieces of equipment. Tuning is done by connecting a test signal generator or using a video tape with a recorded test signal and adjusting the television receiver's tuning dials.

The BA7004 has been designed to operate with a minimum number of external components and it uses a ceramic oscillator to give an accurate video signal (horizontal sync signal and white signal). Unlike the conventional multivibrator method, use of the BA7004 allows the horizontal sync signal setting adjustment procedure to be eliminated which facilitates adjustment and leads to cost savings.

●Features

- 1) Few external components required.
- 2) Provides an accurate video signal without adjustment.
- 3) Good temperature stability.

●Block diagram

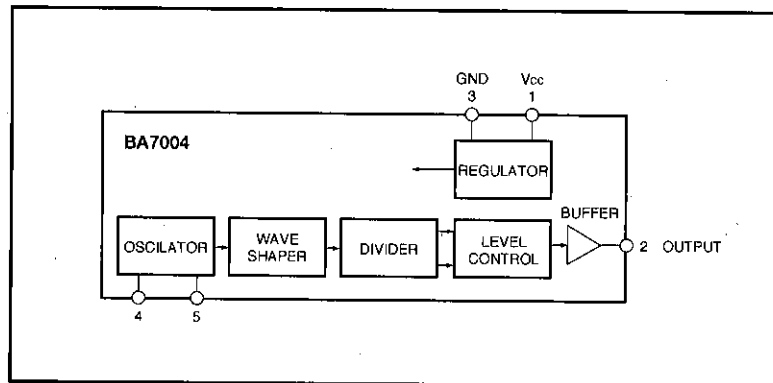

●Absolute maximum ratings (Ta=25°C)

Parameter	Symbol	Limits	Unit
Power supply voltage	V _{cc}	15	V
Power dissipation	P _d	400 *	mW
Operating temperature	T _{opr}	-10~75	°C
Storage temperature	T _{stg}	-55~125	°C
Driving current	I _o	10	mA

* Reduced by 4.0mW for each increase in Ta of 1°C over 25°C.

●Electrical characteristics (Unless otherwise specified Ta=25°C and Vcc=9V)

Parameter	Symbol	Min.	Typ.	Max.	Unit	Conditions	Measurement Circuit
VS ratio	Vs	7.0 : 3.0	6.5 : 3.5	6.0 : 4.0	—	—	Fig.1
Horizontal sync frequency variation	fs	—	15.625	—	kHz	When the CSB500E5 is used	Fig.1
Horizontal sync signal width variation	Hs	3.8	4.2	4.6	μs	—	Fig.1
Operating voltage	Vcc	8	9	13	V	—	Fig.1
Quiescent current	Iq	4.5	9	12.5	mA	—	Fig.1
Peak level	Vp-P	1.7	1.9	2.1	V	—	Fig.1
SYNC - 1st white signal rise time	Tv(1)	22	24	26	μs	—	Fig.1
SYNC - 2nd white signal rise time	Tv(2)	38	40	42	μs	—	Fig.1
White signal width variation	Hv	3.8	4.3	4.8	μs	—	Fig.1

●Measurement circuit

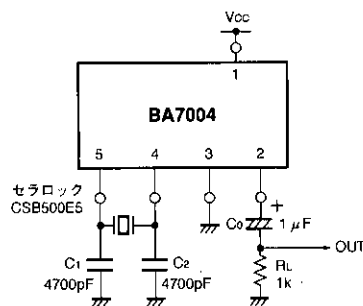
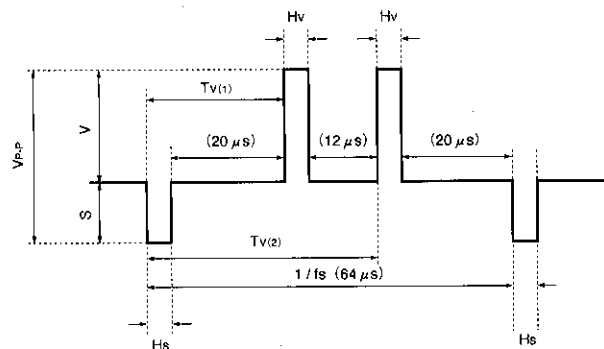

Fig.1



Note: Values in parentheses are typical values.

Fig. 2 Output waveform

●External components

- 1)Ceramic resonator
Murata CSB500E5
- 2)C1 and C2
4700pF (recommended)

- 3)Co
Output coupling capacitor
- 4)RL
Load resistor. Normally the load of the IC is the RF converter video-signal input impedance.

●Application example

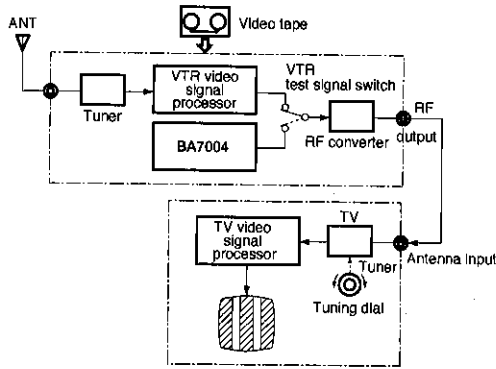

Fig. 3 Connection example

●Electrical characteristic curves (Ta=25°C)

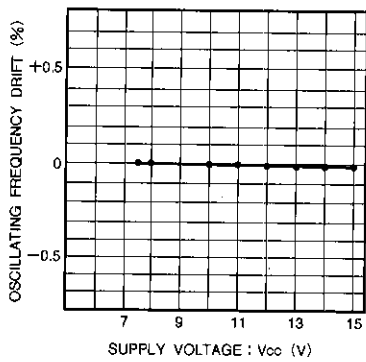

Fig. 4 Oscillation frequency vs. supply voltage

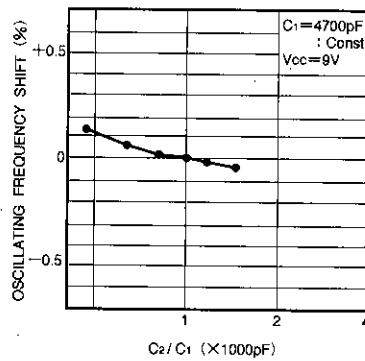

Fig. 5 Oscillation frequency vs. C₂/C₁

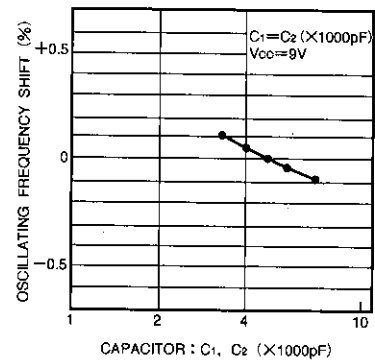

Fig. 6 Oscillation frequency vs. C₂, C₁

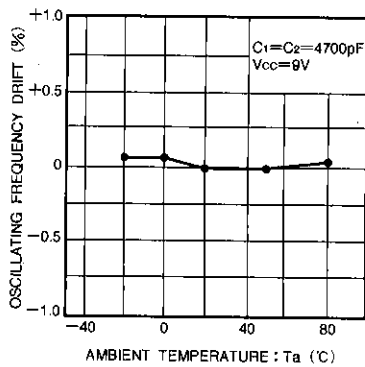

Fig. 7 Oscillation frequency drift vs. ambient temperature

Test pattern generator

VCR components

● External dimensions (Units: mm)

