

FREQUENCY DEMODULATOR AND DROP OUT COMPENSATOR FOR VIDEO RECORDERS

GENERAL DESCRIPTION

The TDA3730 is a monolithic integrated circuit for luminance processing in the playback path of video recorders. The device incorporates two signal channels, one for the main signal and one for the drop out signal.

Features

- FM preamplifier
- Limiter in main and drop out channel
- Demodulator in main and drop out channel
- Drop out detector with Schmitt-trigger
- Electronic switches for FM and video signal controlled by drop out detector
- Linear and dynamic video de-emphasis
- D.C. reference stabilizer

QUICK REFERENCE DATA

Supply voltage (pin 7 and pin 23)	$V_P = V_{7, 23-5, 25}$	typ.	10 V
Supply current (pin 7 + pin 23)	$I_P = I_7 + I_{23}$	typ.	40 mA
FM input signal (pin 17) (peak-to-peak value)	$V_{17-25(p-p)}$	typ.	100 mV
Video output signal (pin 26) (peak-to-peak value)	$V_{26-5(p-p)}$	typ.	2 V

PACKAGE OUTLINE

28-lead DIL; plastic (SOT117).

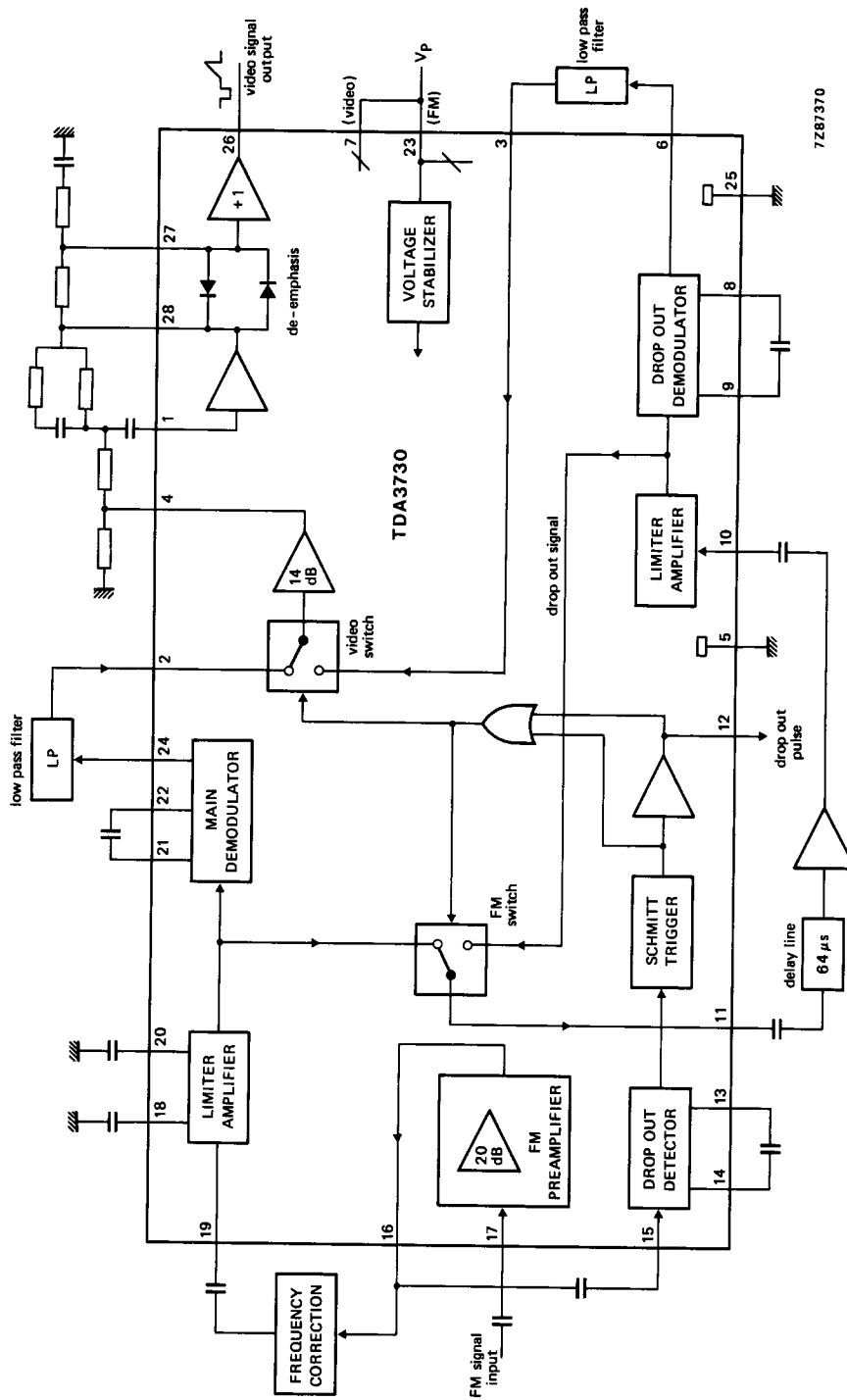

7267370

Fig. 1 Block diagram.

RATINGS

Limiting values in accordance with the Absolute Maximum System (IEC 134)

Supply voltage (pins 7 and 23)	$V_P = V_{7,23-5,25}$	max.	13,2 V
Voltage range at pins 1, 2, 3, 4, 5, 6, 10, 11, 12, 15, 16, 17, 18, 19, 20, 24, 26 to pin 5 and 25 (ground)	$V_{n-5,25}$		0 to V_P V
Voltage at pins 8, 9, 13, 14, 21, 22 to pin 5 and 25 (ground)	$V_{n-5,25}$	max.	V_P V
Voltage at pins 27, 28 to pin 5 and 25 (ground)	$V_{n-5,25}$	min.	0 V
Currents			
at pins 8, 9, 13, 14, 21, 22	$-I_n$	max.	3 mA
at pins 27 and 28	I_n	max.	3 mA
Total power dissipation	P_{tot}	max.	1,4 W
Storage temperature range	T_{stg}		-25 to +150 °C
Operating ambient temperature range	T_{amb}		0 to +70 °C

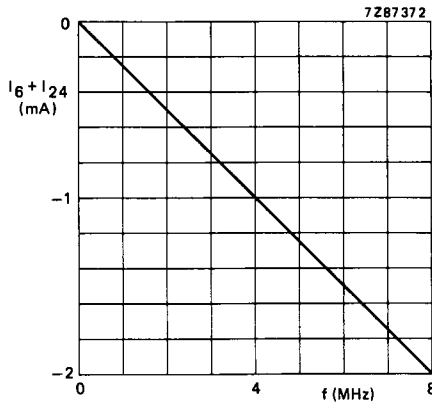

Fig. 2 Steepness of the main and drop out demodulator.

CHARACTERISTICS

$V_P = V_{7, 23-5, 25} = 10 \text{ V}$; $T_{\text{amb}} = 25 \text{ }^\circ\text{C}$; measured in test circuit Fig. 3; unless otherwise specified

parameter	symbol	min.	typ.	max.	unit
Supply (pin 7 and pin 23)					
Supply voltage	$V_P = V_{7, 23-5, 25}$	9,6	10	13,2	V
Supply current	$I_{P1} = I_7$	—	23	—	mA
	$I_{P2} = I_{23}$	—	17	—	mA
FM amplifier					
Input voltage (pin 17) (peak-to-peak value)	$V_{17-25(p-p)}$	—	100	—	mV
Input resistance	R_{17-25}	10	—	—	k Ω
Gain	G_V	—	20	—	dB
Bandwidth ($R_G \leq 50 \Omega$)	B	—	12	—	MHz
Output signal amplitude (pin 16) (peak-to-peak value)	$V_{16-25(p-p)}$	—	—	1,3	V
Main limiter amplifier (pin 19)					
FM input signal (peak-to-peak value)	$V_{19-25(p-p)}$	—	0,5	1	V
Input resistance	R_{19-25}	—	600	—	Ω
Start of limiting (referred to pin 11) (peak-to-peak value)	$V_{19-25(p-p)}$	—	—	2,5	mV
Drop out limiter amplifier (pin 10)					
FM input signal (peak-to-peak value)	$V_{10-5(p-p)}$	—	—	0,8	V
Input resistance	R_{10-5}	—	1	—	k Ω
Start of limiting (referred to pin 11) (peak-to-peak value)	$V_{10-5(p-p)}$	—	—	80	mV
Main and drop out demodulators					
Range of output voltages (pin 6 and pin 24) (peak-to-peak value)	$V_{6, 24-5, 25(p-p)}$	—	—	3,5	V
Linearity (bandwidth = 1 to 6 MHz)		-5	—	+5	%
Steepness (see Fig. 2)	S	—	0,25	—	mA/MHz
FM switch (pin 11)					
Output amplitude (peak-to-peak value)	$V_{11-5(p-p)}$	—	0,5	—	V
D.C. output voltage	V_{11-5}	—	8,4	—	V

parameter	symbol	min.	typ.	max.	unit
Video switch (pin 4)					
Input voltage (pin 2 and pin 3) (peak-to-peak value)	$V_{2, 3-5(p-p)}$	—	—	0,5	V
Input resistance (open base)	$R_{2, 3-5}$	20	—	—	k Ω
Voltage gain	G_v	—	14	—	dB
D.C. output voltage at $V_{2, 3-5} = 9,5$ V	V_{4-5}	—	5,4	—	V
De-emphasis amplifier (linear)					
Video output signal (pin 28) (peak-to-peak value)	$V_{28-5(p-p)}$	—	—	3	V
Gain-bandwidth product	G.B.	30	—	—	MHz
D.C. output voltage	V_{28-5}	—	4,8	—	V
Dynamic de-emphasis					
Output signal (pin 26) (peak-to-peak value) at $V_{28-5(p-p)} = 1$ V; $f = 1$ MHz sine	$V_{26-5(p-p)}$	—	632	—	mV
D.C. output voltage	V_{26-5}	—	3,4	—	V
Output current (emitter follower)	$-I_{26}$	—	—	5	mA
Drop out detector and Schmitt-trigger					
Input voltage for lower drop out threshold (pin 15) (peak-to-peak value)	$V_{15-5(p-p)}$	—	110	—	mV
Hysteresis of the Schmitt-trigger	V/V	—	1,5	—	dB
Input resistance	R_{15-5}	1,4	—	—	k Ω
D.C. output voltage without drop out	V_{12-5}	—	—	2	V
D.C. output voltage with drop out	V_{12-5}	5	—	—	V
OR-gate (internal)					
Switching voltage threshold (pin 12) for signal flow from pin 2 to pin 4	V_{12-5}	—	—	1,5	V
for signal flow from pin 3 to pin 4	V_{12-5}	3	—	—	V

APPLICATION INFORMATION

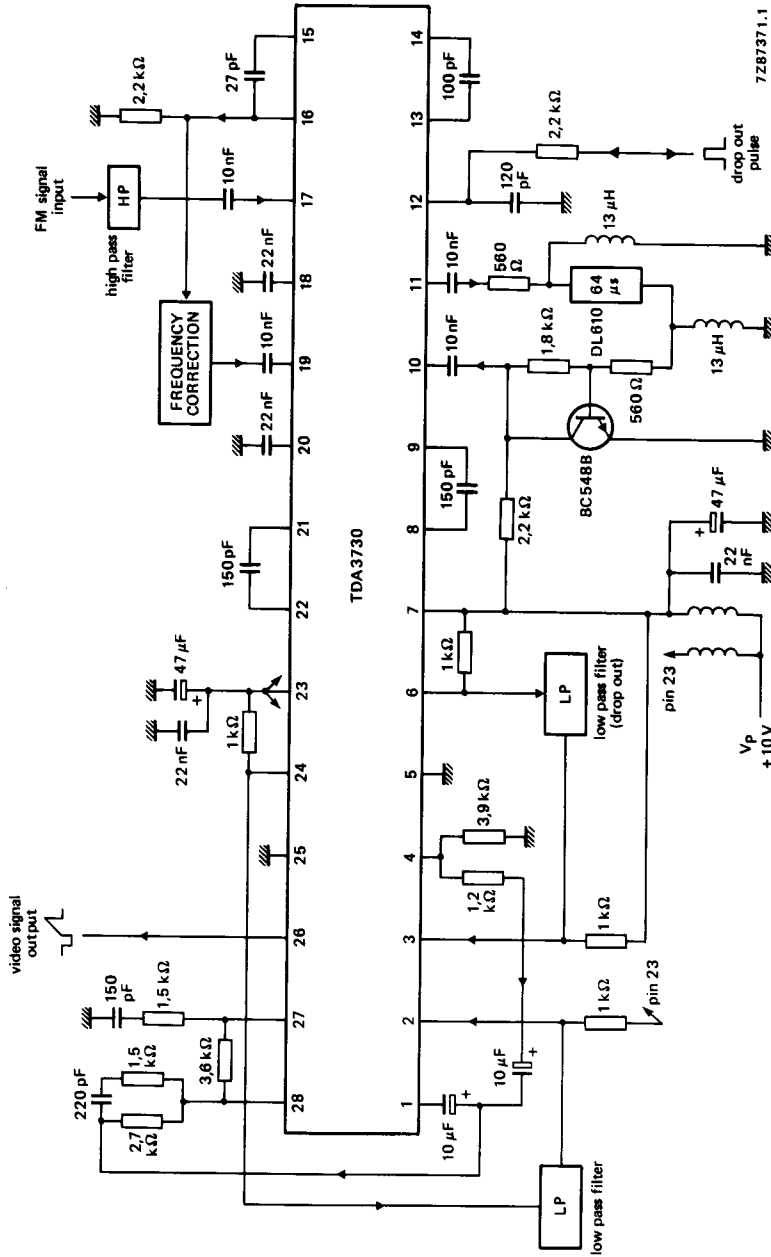

Fig. 3 Application diagram; also used as test circuit.