

TA7676P

TV PRIMARY COLOR SIGNAL PREAMPLIFIER WITH DATA
INPUT TERMINALS FOR TELETEXT etc.

FUNCTION

- . PAL/SECAM System Switch
- . PAL/SECAM Color Control
- . SECAM Sub Color Control
- . Matrix
- . TV Color Difference Signal Converted to Primary Color.
- . Clamp Circuit by Line Pulse.
- . Blanking Pulse by Field Pulse.
- . Line Pulse, Field Pulse Amplifier.
- . Video Amplifier.
- . Brightness Control.
- . TV Video and DATA Switch.
- . Data Input (R,G,B)

FEATURE

- . In combination with TA7621P (SECAM, color process/demod) and TA7193P (PAL, color process/demod), PAL/SECAM dual system can be constructed.
- . TV video signal and R-Y, B-Y signals are transfer to R,G,B primary color internally.
- . R,G,B three input terminals are available for DATA input and the selection of DATA input or TV signals are selected by video/data switch.

Unit: mm

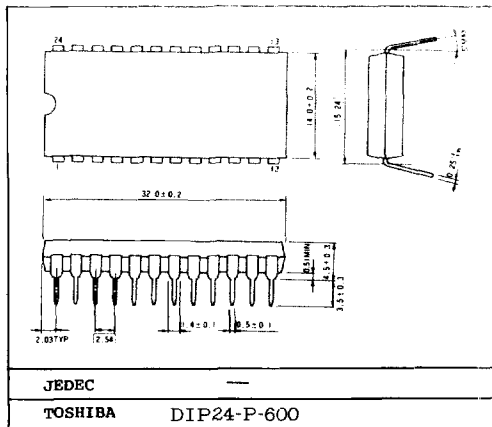

TA7676P

BLOCK DIAGRAM

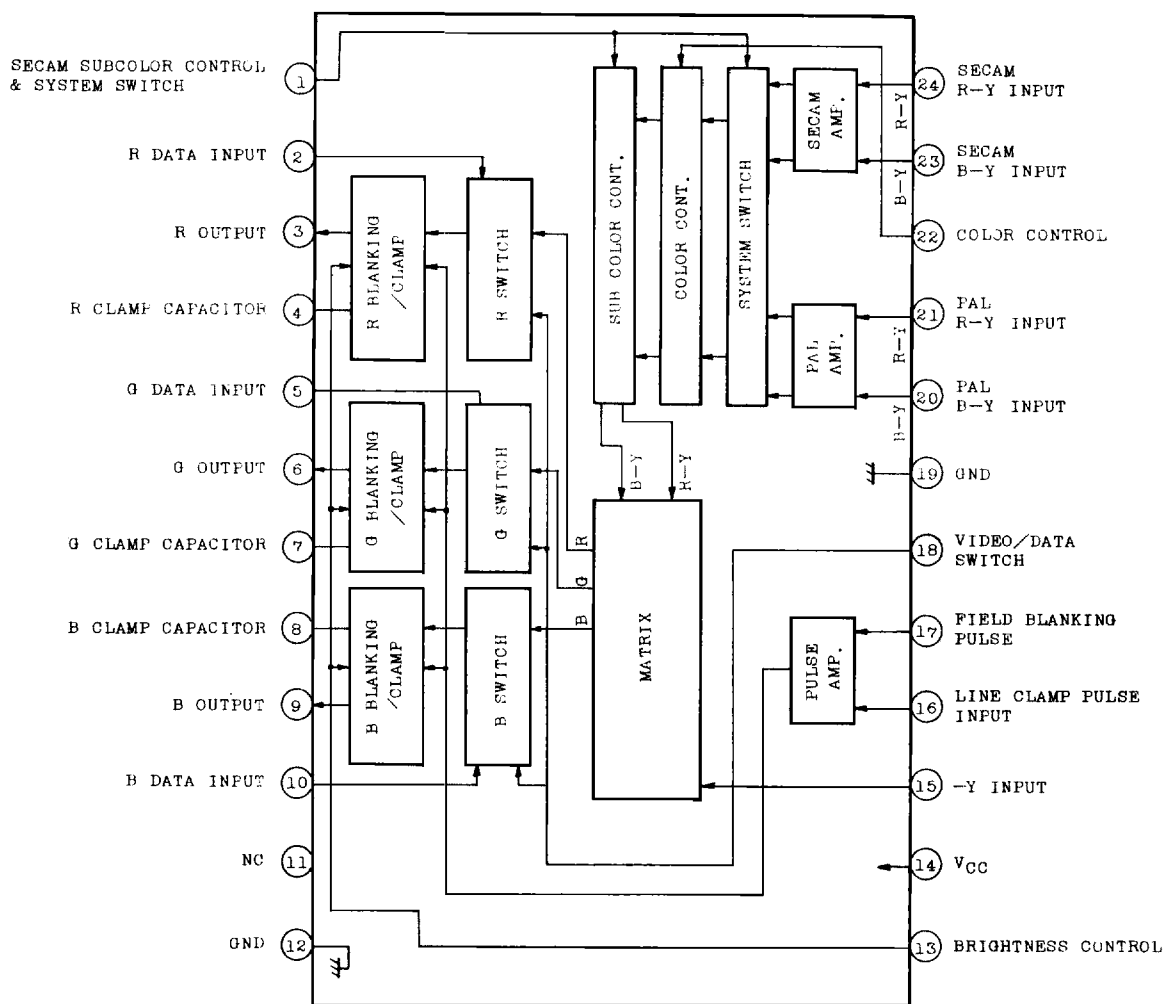

TA7676P

MAXIMUM RATINGS ($T_a=25^{\circ}\text{C}$)

CHARACTERISTIC	SYMBOL	RATING	UNIT
Supply Voltage	V_{CC}	15	V
Signal Level at Input Pin	e 2MAX. e 5MAX. e 10MAX. e 15MAX. e 20MAX. e 21MAX. e 23MAX. e 24MAX.	5	V_{p-p}
Color Output Current	$I_O(\text{DC})$	3.5	mA
	$I_O(\text{AC})$	5	mA
Color Control Input Voltage	V_{22} MAX.	15	V
PAL/SECAM Switch Input Voltage	V_1 MAX.	15	V
Brightness Control Input Voltage	V_{13} MAX.	15	V
Video/Data Switch Input Voltage	V_{18} MAX.	5	V_{p-p}
Line Clamp Pulse Input Voltage	V_{16} MAX.	± 5	V
Field Blanking Input Voltage	V_{17} MAX.	± 5	V
Power Dissipation (Note)	P_D	1.2	W
Operating Temperature	T_{opr}	-20 ~ 65	$^{\circ}\text{C}$
Storage Temperature	T_{stg}	-55 ~ 150	$^{\circ}\text{C}$

Note : Derated above $T_a=25^{\circ}\text{C}$ in the proportion of $9.6\text{mW}/^{\circ}\text{C}$.

TA7676P

ELECTRICAL CHARACTERISTICS (Unless otherwise specified, $V_{CC}=12V$, $T_a=25^{\circ}C$)

CHARACTERISTIC	SYMBOL	TEST CIR-CUIT	TEST CONDITION	MIN.	TYP.	MAX.	UNIT
Supply Voltage	V_{CC}	-	-	10.8	12	13.2	V
Supply Current	I_{CC}	1	-	36	52	67	mA
Power Dissipation	P_D	1	-	-	620	-	mW

PAL/SECAM AMP, RGB MATRIX (1)

PAL/SECAM Input Voltage		V_{20}, V_{21} V_{23}, V_{24}	1	Terminal 20, 21, 23, 24 Voltage	1.65	1.95	2.25	V
PAL/SECAM Input Dynamic Range		$V_{DCI}(PAL)$ $V_{DCI}(SECAM)$	2	$V_{22}=V_{CC}, V_{13}=6V$ (Note 1)	0.4	0.5	-	V_{p-p}
R.G.B Output Dynamic Range		$v_{OB} MAX.$	2	$V_{22}=V_{CC}, V_{13}=6V$ (Note 2)	4	5	-	V_{p-p}
PAL/SECAM Max.Gain	R-Y	$G_{MAX}(R-Y)$	2	$V_{22}=V_{CC}, V_{13}=6V$ (Note 3)	14	16	18	dB
	B-Y	$G_{MAX}(B-Y)$	2	$V_{22}=V_{CC}, V_{13}=6V$ (Note 4)	18	20	22	dB
Relative Ratio of Color Output		B/R	2	$V_{22}=V_{CC}, V_{13}=6V$ (Note 5)	1.4	1.55	1.71	-
		G/R	2	$V_{22}=V_{CC}, V_{13}=6V$ (Note 5)	0.46	0.51	0.56	-
		G/B	2	$V_{22}=V_{CC}, V_{13}=6V$ (Note 5)	0.17	0.19	0.21	-
Color Cont. Terminal Voltage		V_{22}	1	Voltage of Terminal 22	4.9	5.6	6.3	V
Max. Gain Reduction of Color Cont.		ΔV_C	2	(Note 6)	-	-	-	
		$\Delta V_C(1)$		$V_{22}=5 \sim 10V$	-	10	-	dB
		$\Delta V_C(2)$		$V_{22}=6.3 \sim 10V$	-	3	-	dB

TA7676P

CHARACTERISTIC	SYMBOL	TEST CIR-CUIT	TEST CONDITION	MIN.	TYP.	MAX.	UNIT
PAL/SECAM AMP., RGB MATRIX (2)							
Color Gain Change by Supply Voltage Variation	$G_{MAX. (B-Y)V}$	2	$V_{CC}=10.8 \sim 13.2V$ (Note 4)	-0.5	0	0.5	dB/V
Color Gain Thermal Drift	$G_{MAX. (B-Y)\theta}$	2	$T_a=-10^{\circ}C \sim 65^{\circ}C$ (Note 4)	-0.04	0	0.04	dB/ $^{\circ}C$
PAL/SECAM Switching Level L : PAL H : SECAM	V_{ISW}	2	$V_{22}=V_{CC}, V_{13}=6V$ (Note 7)	2.0	2.8	3.6	V
Max. Gain Reduction of Sub Color Cont.	ΔV_{SUB}	2	$V_{22}=V_{CC}, V_{13}=6V$ $V_1=7.2 \sim 12V$ (Note 8)	-	12	-	dB
	$\Delta V_{SUB(1)}$			-	6	-	
	$\Delta V_{SUB(2)}$			-	3	-	
PAL/SECAM Crosstalk	V_{CTP-S} V_{CTS-P}	2	$V_{22}=V_{CC}, V_{13}=6V$ (Note 8)	-	10	100	mV _{p-p}
Error Voltage Between Bright Cont. Voltage & Clamp Level	$V_{OC3-V13}$	3	$V_{13}=4 \sim 8V, V_{BP}=0V$ (Note 10)	-0.4	-0.2	0	V
	$V_{OC6-V13}$						
	$V_{OC9-V13}$						
Offset of Clamp Level	ΔV_{OC3-6}	3	$V_{13}=6V, V_{BP}=0V$	-0.3	0	0.3	V
	ΔV_{OC6-9}						
	ΔV_{OC9-3}						
Clamp Terminal Voltage	V_{C4}	3	$V_{13}=6V, V_{BP}=0V$ During Clamping Period	4.0	4.3	4.6	V
	V_{C7}						
	V_{C8}						
Brightness Control Range	ΔV_{13}	3	$V_{BP}=0V$	4.0	-	9.5	V
Sink Current of Bright Cont. Terminal	I_{13}	1	$V_B=4V$	-	-	50	μA
DC Level Shift of Color Output by Color Cont.	$\Delta V_{OC}(\text{Color})$	3	$V_{22}=0V \sim V_{CC}, V_{BP}=0V$ During Clamping Period	-50	0	50	mV
Variation of Offset of Color Outputs by Color Cont. and Bright Cont.	$\Delta V_{OC3-6(R,G)}$	3	$V_{22}=0V \sim V_{CC}, V_{BP}=0V$ $V_{13}=3 \sim 9V$ During Clamping Period	-50	0	50	mV
	$\Delta V_{OC6-9(G,B)}$						
	$\Delta V_{OC9-3(B,R)}$						
Color Output Temperature Drift	$\Delta V_{OC\theta}$	3	$V_{22}=V_{CC}, V_{BP}=0V,$ $V_{13}=6V$	-	0	-	mV/ $^{\circ}C$

TA7676P

CHARACTERISTIC	SYMBOL	TEST CIR-CUIT	TEST CONDITION	MIN.	TYP.	MAX.	UNIT
----------------	--------	---------------	----------------	------	------	------	------

PAL/SECAM AMP., RGB MATRIX (3)

Color Output Blanking Level	V_{OB3} V_{OG6} V_{OR9}	3	$V_{22}=V_{CC}, V_{13}=6V$	1.7	2.0	2.3	V
Offset of Color Blanking Level	ΔV_{OB3-6} ΔV_{OG6-9} ΔV_{OR9-3}	3	$V_{22}=V_{CC}, V_{13}=6V$	-0.3	0	0.3	V
Line Clamp Pulse Input Level	V_C	3	#17=0V	-	1.4	2.0	V
Blanking Pulse Input Level	V_B	3	#16=0V	-	0.8	1.2	V

VIDEO AMP.

Input Dynamic Range	V_{YI}	4	$V_{13}=6V$	2.5	3.5	-	V_{p-p}
Gain	G_Y	4	$V_{13}=6V, 20 \log \frac{v_{B9}}{v_{15}}$	1.2	3.2	5.2	dB
Input Terminal Clamp Level	V_{C15}	3	$V_{13}=6V$, During Clamping Period	6.0	6.3	6.6	V

DATA INPUT

Input Dynamic Range	V_{DI}	5	$V_{V/D}=2V, V_{13}=6V$ (Note 11)	0.4	0.5	-	V_{p-p}
Gain	G_D	5	$V_{13}=6V$ (Note 12)	18	20	22	dB
Offset of Black Level Between TV Signal and Data	ΔV_B	3	$V_{13}=6V$ (Note 13)	-	100	300	mV
Rise Time of Output	t_r	3	$V_{V/D}=2V, V_{13}=6V$ (Note 14)	-	50	-	nsec
R,G,B Output Time Lag Difference	Δt_{pH}	5	(Note 15)	-	20	-	nsec

VIDEO/DATA SWITCH

Data Input ON Level	$V_{18 ON}$	5	$v_{CP}=0V$ (Note 16)	0.9	-	-	V
Data Input OFF Level	$V_{18 OFF}$	5	$v_{CP}=0V$ (Note 17)	-	0.3	-	V
Switching Speed	t_d	5	$v_{CP}=0V$ (Note 18)	-	40	-	nsec

TA7676P

TEST CONDITION

Note 1. PAL/SECAM Input Dynamic Range

$$V_{CP}=4.3V, V_Y=5.5V$$

$$\text{PAL} : V_1=0V, V_{22}=V_{CC}, V_{13}=6V$$

SG₂/SG₃/SG₄ : Disconnect.

Read SG₁ when #9 start to saturate.

$$\text{SECAM} : V_1=V_{CC}, V_{22}=V_{CC}, V_{13}=6V$$

SG₁/SG₂/SG₄ : Disconnect

Read SG₃ when #9 start to saturate.

Note 2. By same condition read the amplitude of #9 .

Note 3. R-Y Max. Gain

$$V_{CP}=4.3V, V_Y=5.5V$$

$$\text{PAL} : V_1=0V, V_{22}=V_{CC}, V_{13}=6V$$

SG₁, SG₃, SG₄ : Disconnect

$$G_{\text{MAX. (R-Y)}} = 20 \log \frac{v_{3R}}{v_{21}}$$

$$\text{SECAM} : V_1=V_{CC}, V_{22}=V_{CC}, V_{13}=6V$$

SG₁, SG₂, SG₃ : Disconnect

$$G_{\text{MAX. (R-Y)}} = 20 \log \frac{v_{3R}}{v_{24}}$$

Note 4. B-Y Max. Gain

$$V_{CP}=4.3V, V_Y=5.5V$$

$$\text{PAL} : V_1=0V, V_{22}=V_{CC}, V_{13}=6V$$

SG₂, SG₃, SG₄ : Disconnect

$$G_{\text{MAX. (B-Y)}} = 20 \log \frac{v_{9B}}{v_{20}}$$

$$\text{SECAM} : V_1=V_{CC}, V_{22}=V_{CC}, V_{13}=6V$$

SG₁, SG₂, SG₄ : Disconnect

$$G_{\text{MAX. (B-Y)}} = 20 \log \frac{v_{9B}}{v_{23}}$$

Note 5. Relative Ratio of Color Output

$$V_{CP}=4.3V, V_Y=5.5V, V_{22}=V_{CC}, V_{13}=6V$$

$$\text{PAL} : V_1=0V$$

$$\text{SG}_3, \text{SG}_4 : \frac{R}{B} = \frac{v_{3R}}{v_{9B}} \quad \frac{G}{R} = \frac{v_{6G}}{v_{3R}} \quad \frac{G}{B} = \frac{v_{6G}}{v_{9B}}$$

TA7676P

SECAM : $V_1=V_{CC}$
 SG₁, SG₂ : Disconnect

Note 6. Max. Gain Reduction of Color Control

$V_{CP}=4.3V$, $V_Y=5.5V$, $V_{13}=6V$, $V_1=0V$
 SG₂, SG₃, SG₄ : Disconnect
 Read the amplitude change of #9 amplitude by #22 change of from V_{CC} to 0V.

Note 7. PAL/SECAM Switching Level

$V_{CP}=4.3V$, $V_Y=5.5V$, $V_{22}=V_{CC}$, $V_{13}=6V$
 SG₂, SG₃, SG₄ : Disconnect
 Read the #18 voltage reducing from 12V when 100kHz signal appears at #9.

Note 8. Max. Gain Reduction of Subcolor Control

$V_{CP}=4.3V$, $V_Y=5.5V$, $V_{22}=V_{CC}$, $V_{13}=6V$
 SG₂, SG₃, SG₄ : Disconnect
 Read amplitude change of #9 changing #1 from 12V to 4V.

Note 9. PAL/SECAM Cross Talk

PAL → SECAM : $V_{CTR} \rightarrow S$,
 $V_1=V_{CC}$
 SG₃, SG₄ : Disconnect
 Read the 100kHz signal level at #3,, #6 and #9.
 SECAM → PAL : $V_{CTS} P$,
 $V_1=0V$
 SG₁, SG₂ : Disconnect
 Read the 100kHz signal level at #3, #6 and #9.

Note 10. Error Voltage Between Bright Cont. & Clamp Level

$V_{13}=4 \sim 8V$, $V_{BP}=0V$
 Read the voltage difference between #11 & #3, #6 and #9 during clamping period.

TA7676P

Note 11. Input Dynamic Range

#18=2V, $V_{13}=6V$

Read the input level of #2, #5 and #10 which will start to saturate the chroma output.

Gain of Data.

Note 12. Same Test Condition as in Note 11 and Calculate,

$$20 \log \frac{v_{9B}}{v_{10}}, \quad 20 \log \frac{v_{6G}}{v_5}, \quad 20 \log \frac{v_{3R}}{v_2}$$

Note 13. $V_{13}=6V$

$V_{CP}=4V(DC)$, $v_{BP}=0V$

Read the offset at color outputs between #18 of 0V and 2V.

Note 14. Risetime of Chroma Output

$V_{V/D}=2V$, $V_{13}=6V$

With Fig.1 signal condition, read t_r .

Note 15. Output Time Lag Difference

With Fig.1 signal condition,

read Δt_{pH}

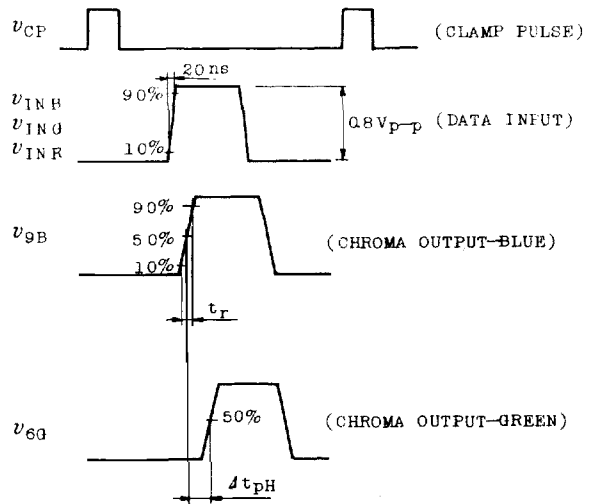

Fig. 1

Note 16. DATA Input On Level

$V_{15}=5.5V$, $V_2=V_5=V_{10}=3.5V$, $V_4=V_7=V_8=4.3V$

Read the #18 rising 0V to 2V, when #9, #6 and #3 change from $\approx 4.5V$ to $\approx 9V$.

TA7676P

Note 17. DATA Input Off Level

$$V_{15}=5.5V, V_2=V_5=V_{10}=3.5V, V_4=V_7=V_8=4.3V$$

Read the #18 decreasing from 2V to 0V, when #9, #6 and #3 change from $\approx 9V$ to $\approx 4.5V$.

Note 18. Switching Speed

$$V_{15}=5.5V, V_2=V_5=V_{10}=3.5V,$$

$$V_4=V_7=V_8=4.3V$$

As in Fig.2, Read the t_d .

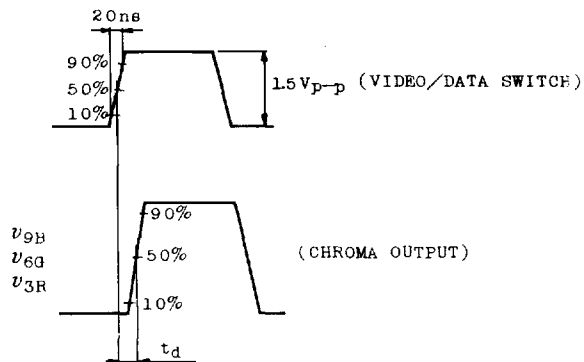
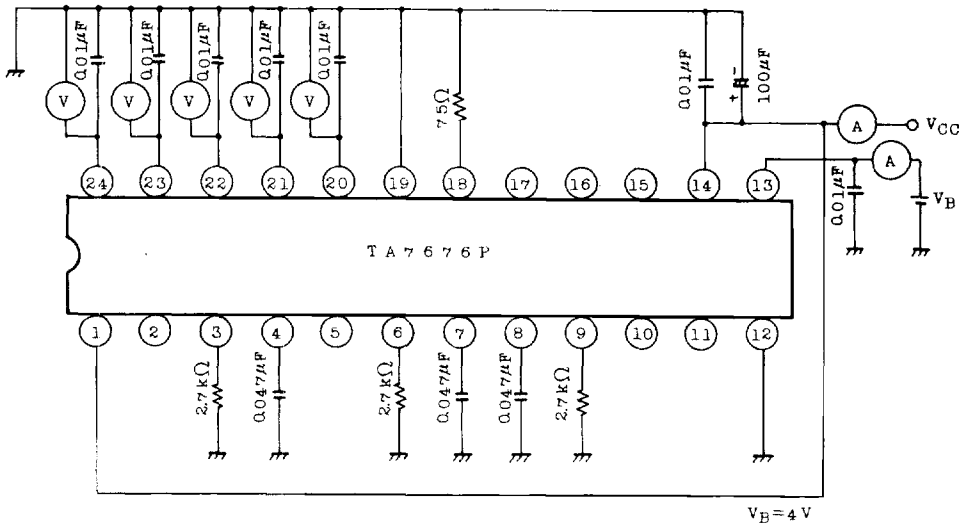

Fig. 2

TA7676P

TEST CIRCUIT

1. DC CHARACTERISTICS



2. PAL/SECAM AMP

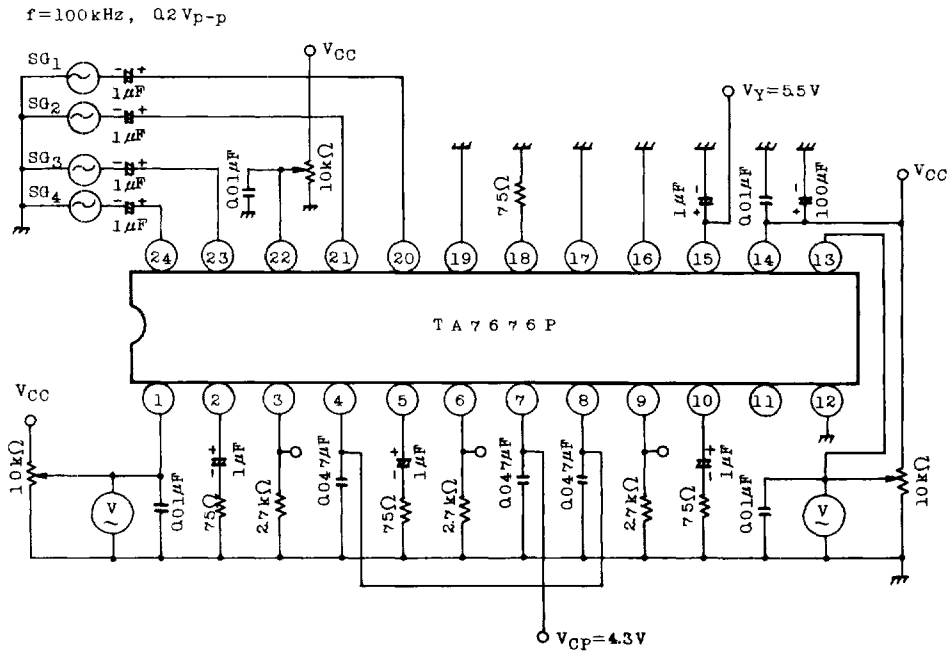

TA7676P

3. BLANKING LEVEL, CLAMP LEVEL

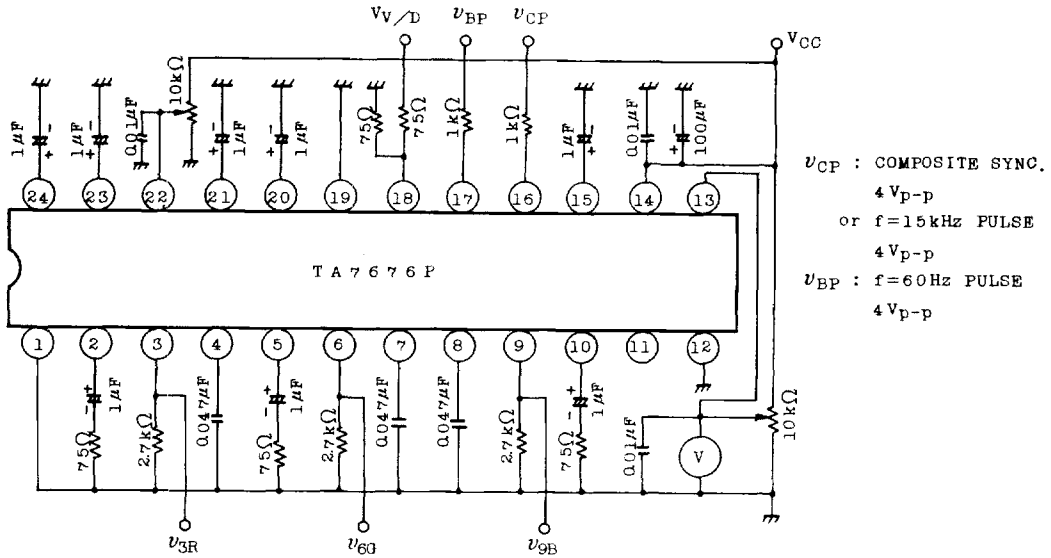

4. VIDEO AMP

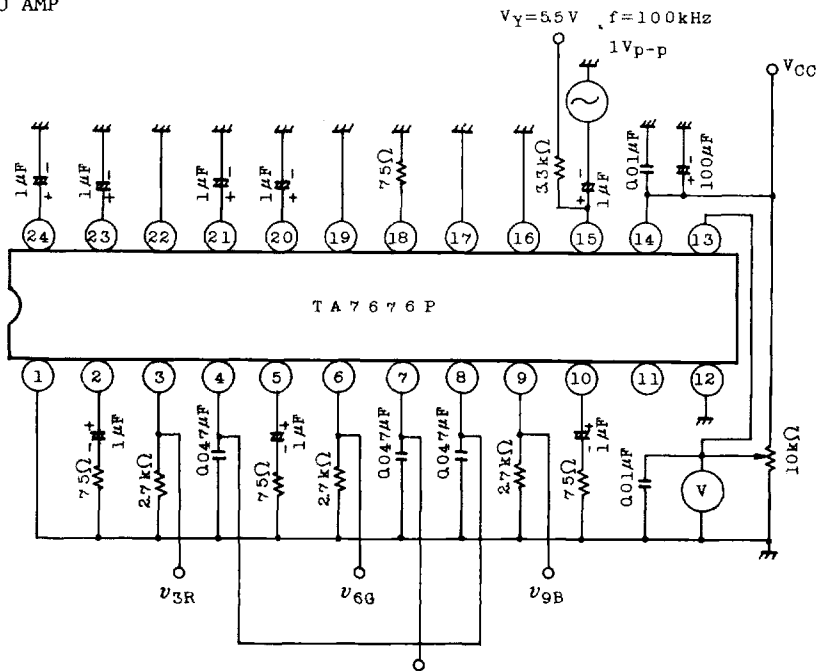

TA7676P

5. DATA INPUT CHARACTERISTICS

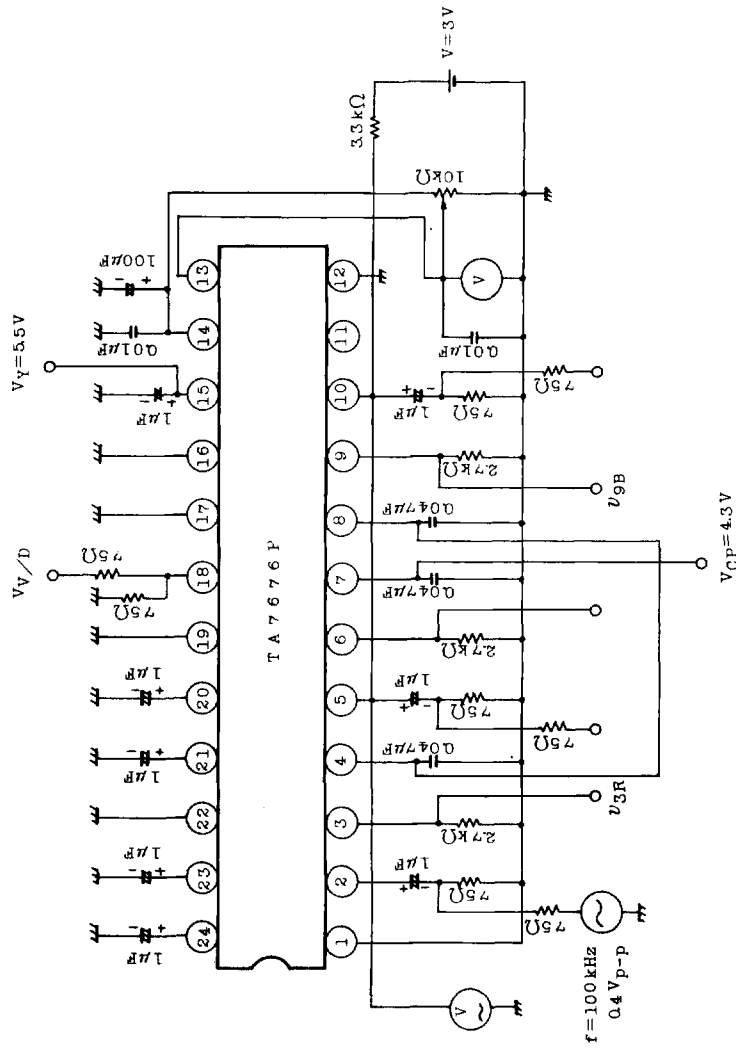

TA7676P

