

# AN6230S

## 450mW Audio Power Amplifier Circuit

### Overview

The AN6230S is an integrated circuit designed for power amplifier for 3V operated micro cassette tape recorder and compact cassette deck incorporating speaker amplifier, earphone amplifier and battery checker.

### Features

- High output power
- Low current consumption
- Low ON-OFF shock noise
- Built-in supply voltage check circuit

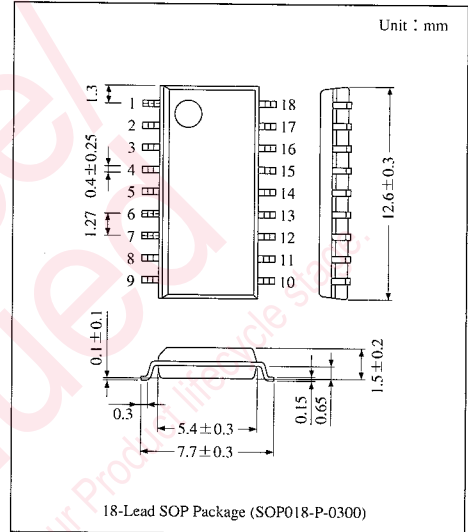

### Block Diagram

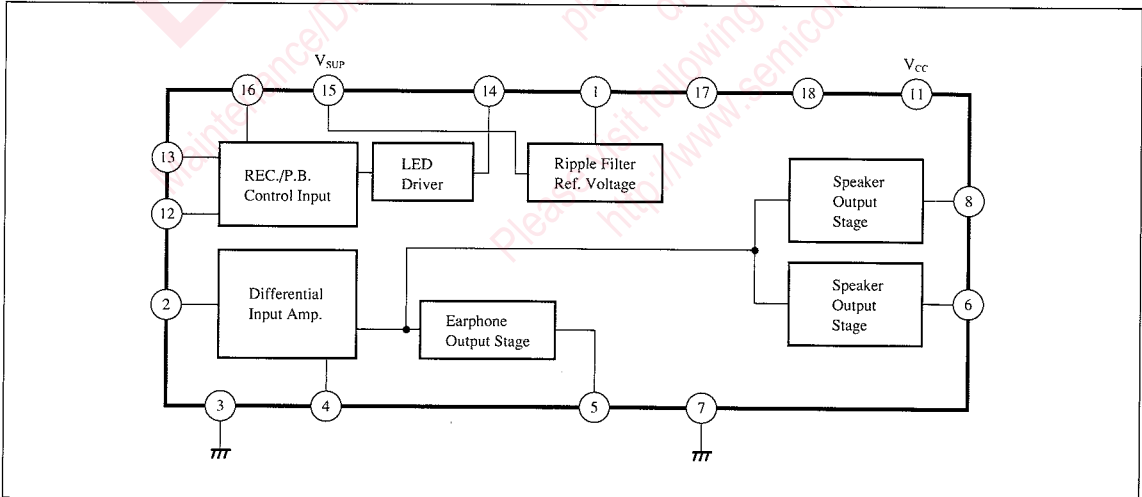

ICs for  
Cassette  
Deck

### ■ Absolute Maximum Ratings (Ta = 25°C)

| Parameter                     | Symbol              | Rating     | Unit |
|-------------------------------|---------------------|------------|------|
| Supply Voltage                | V <sub>CC</sub>     | 6          | V    |
| Supply Current                | I <sub>CC</sub>     | 550        | mA   |
| Power Dissipation *           | P <sub>D</sub>      | 900        | mW   |
| Speaker Amp. Output Current   | I <sub>O(SP)</sub>  | 500        | mA   |
| Earphone Output Current       | I <sub>O(EP)</sub>  | 125        | mA   |
| LED Drive Current             | I <sub>O(LED)</sub> | 10         | mA   |
| Operating Ambient Temperature | T <sub>opr</sub>    | -20 ~ +75  | °C   |
| Storage Temperature           | T <sub>stg</sub>    | -55 ~ +125 | °C   |

\* With a 10cm × 10cm printed circuit board

### ■ Electrical Characteristics (V<sub>CC</sub> = 3V, f = 1kHz, Ta = 25°C)

| Parameter   | Symbol                 | Condition   | min. | typ. | max.                 | Unit |
|---|------------------------|---|------|------|----------------------|------|
| Speaker Amp. Quiescent Circuit Current              | I <sub>CQ1</sub>       |   | 5    | 10   | 15                   | mA   |
| Speaker Amp. Voltage Gain                           | G <sub>VC(SP)</sub>    | f = 1kHz, V <sub>O</sub> = 1V                     | 48.0 | 49.5 | 51.0                 | dB   |
| Speaker Amp. Output Power                           | P <sub>O(SP)</sub>     | f = 1kHz, THD = 10%                               | 400  | 450  | 600                  | mW   |
| Speaker Amp. Total Harmonic Distortion              | THD <sub>(SP)</sub>    | f = 1kHz, P <sub>O</sub> = 100mW                  | —    | 2.0  | 3.0                  | %    |
| Speaker Amp. Output Noise Voltage                   | V <sub>no(SP)</sub>    | R <sub>g</sub> = 0Ω, DIN AUDIO                    | —    | 0.2  | 0.5                  | mV   |
| Earphone Amp. Quiescent Circuit Current             | I <sub>CQ2</sub>       |   | 3    | 7    | 8.5                  | mA   |
| Earphone Amp. Voltage Gain                          | G <sub>VC(EP)</sub>    | f = 1kHz, V <sub>O</sub> = 0.1V                   | 28.5 | 30.0 | 31.5                 | dB   |
| Earphone Amp. Output Power                          | P <sub>O(EP)</sub>     | f = 1kHz, THD = 10%                               | 8    | 11   | —                    | mW   |
| Earphone Amp. Output Noise Voltage                  | V <sub>no(EP)</sub>    | R <sub>g</sub> = 0Ω, DIN AUDIO                    | —    | 0.03 | 0.07                 | mV   |
| Battery Check ON Voltage                            | V <sub>iHL</sub>       | REC. Mode, V <sub>CC</sub> : 0V → V <sub>CC</sub> | 2.3  | 2.4  | 2.5                  | V    |
| Battery Check OFF Voltage                           | V <sub>iLH</sub>       | REC. Mode, V <sub>CC</sub> : 2.4V → 0V            | 1.98 | 2.08 | 2.18                 | V    |
| Earphone/Speaker Switching Voltage (Speaker)        | V <sub>i3(SP)</sub>    |   | 1    | —    | V <sub>SUP-0.3</sub> | V    |
| Earphone/Speaker Switching Voltage (Earphone)       | V <sub>i3(EP)</sub>    |   | 0    | —    | 0.3                  | V    |
| Playback Input Voltage                              | V <sub>i2</sub>        |   | 1.4  | —    | V <sub>SUP</sub>     | V    |
| LED Drive Current                                   | I <sub>SINK14</sub>    | V <sub>14</sub> = 1.3V, V <sub>16</sub> = 1.2V    | 2    | 4    | —                    | mA   |
| DC Offset Voltage of Speaker Amp.                   | V <sub>O(offset)</sub> |   | -35  | 0    | 35                   | mV   |
| Rec./Playback Control Voltage PLAY → MUTE           | V <sub>i(P/M)</sub>    |   | 0.16 | 0.20 | 0.24                 | V    |
| Rec./Playback Control Voltage MUTE → REC.           | V <sub>i(M/R)</sub>    |   | 0.75 | 0.95 | 1.15                 | V    |
| Rec./Playback Control Voltage REC. → MUTE           | V <sub>i(R/M)</sub>    |   | 0.70 | 0.90 | 1.10                 | V    |
| Rec./Playback Control Voltage MUTE → PLAY           | V <sub>i(M/P)</sub>    |   | 0.12 | 0.15 | 0.18                 | V    |
| Rec. Mode Quiescent Current                         | I <sub>CQ3</sub>       | V <sub>i3</sub> = Open                            | —    | 3.0  | 4.0                  | mA   |
| Quiescent Current at the Output Stage (muting mode) | I <sub>CQ4</sub>       |   | —    | 200  | 300                  | μA   |
| Earphone Amp. Total Harmonic Distortion             | THD <sub>(EP)</sub>    | f = 1kHz, V <sub>O</sub> = 0.155V                 | —    | 1.5  | 3                    | %    |
| Speaker Amp. Gain at Decreased Voltage              | G <sub>V(SP2)</sub>    | f = 1kHz, V <sub>i</sub> = -60dBV                 | 41   | 46   | —                    | dB   |
| Ripple Rejection Ratio                              | RR                     | f = 100kHz, R <sub>g</sub> = 0Ω                   | 50   | 65   | —                    | dB   |

## Operational Description

1. This IC incorporates voltage amp. for amplifying voltage, speaker amp. 1, 2, earphone amp., battery checker and LED driver, speaker/earphone switching circuit, control logic circuit at amps., low ripple supply source, click sound protector at power ON.

2. Voltage amplifier

Consists of  $V_1$  (Pin②), NF (Pin④), and gain is determined by grounding Pin④ (Example  $C=6.8\mu\text{F}$ , circuit gain 31dB) AC wise.

3. Speaker amplifier 1.2

BTL amp. consists of speaker amp. 1 and 2. SP out 1 (Pin⑥) is a non-inverting output and SP out 2 (Pin⑧) is inverting output. Gain from  $V_1$  (Pin②) is 49dB when  $8\Omega$  is connected between SP out and SP out 2. Capacitor between SP out 1, 2 and GND is for the protection of oscillation.

4. Earphone amplifier

Earphone amp. is a OTL amp. Gain is  $-2\text{dB}$  when coupling capacitor is  $100\mu\text{F}$  and load is  $8\Omega$ . Gain from  $V_1$  (Pin②) is 29dB.

5. Battery checker

It checks whether  $V_{CC}$  is normal voltage or not, at REC mode (Pin⑩ is set to 1.1V). At REC mode, LED turns on  $V_{CC}$  is more than 2.4V. LED turns off when  $V_{CC}$  becomes less than 2.1V. Hysteresis width is 0.32V and protects error operation of power supply fluctuation.

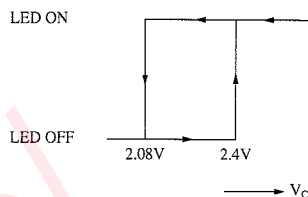

6. Speaker/earphone amplifiers switching circuit

This circuit makes to operator either speaker or earphone amp. When Pin⑬ is OPEN, speaker amp. operates. When Pin⑬ is set to GND, earphone amp. operates.

| Pin⑬ | Speaker/Earphone |
|------|------------------|
| OPEN | Speaker          |
| GND  | Earphone         |

7. Amplifier control logic circuit

Operating of speaker and earphone amp. is controlled by DC current of the Pin⑩.

| Voltage at Pin⑩ | Pin⑬ | Speaker | Earphone |
|-----------------|------|---------|----------|
| 0V~0.15V        | OPEN | ○       | ×        |
|                 | GND  | ×       | ○        |
| 0.25V~0.7V      | OPEN | ×       | ×        |
|                 | GND  | ×       | ×        |
| 1.2V~ $V_{CC}$  | OPEN | ×       | ×        |
|                 | GND  | ×       | ○        |

## Pin Descriptions

| Pin No. | Pin Name           | Pin No. | Pin Name                   |
|---------|--------------------|---------|----------------------------|
| 1       | Ripple Filter      | 10      | NC                         |
| 2       | Input              | 11      | Output Stage ; $V_{CC}$    |
| 3       | GND                | 12      | P.B. Only Control Input    |
| 4       | Feedback Input     | 13      | SP/EP Switching Input      |
| 5       | Earphone Output    | 14      | LED Output                 |
| 6       | Speaker Output (1) | 15      | Pre-Amp. ; $V_{SUP}$       |
| 7       | GND                | 16      | Rec./P.B. Control Input    |
| 8       | Speaker Output (2) | 17      | Microphone ; $V_{CC}$      |
| 9       | NC                 | 18      | Battery Check Voltage Adj. |

ICs for  
Cassette  
Deck

## Request for your special attention and precautions in using the technical information and semiconductors described in this book

- (1) If any of the products or technical information described in this book is to be exported or provided to non-residents, the laws and regulations of the exporting country, especially, those with regard to security export control, must be observed.
- (2) The technical information described in this book is intended only to show the main characteristics and application circuit examples of the products. No license is granted in and to any intellectual property right or other right owned by Panasonic Corporation or any other company. Therefore, no responsibility is assumed by our company as to the infringement upon any such right owned by any other company which may arise as a result of the use of technical information described in this book.
- (3) The products described in this book are intended to be used for standard applications or general electronic equipment (such as office equipment, communications equipment, measuring instruments and household appliances).  
Consult our sales staff in advance for information on the following applications:
  - Special applications (such as for airplanes, aerospace, automobiles, traffic control equipment, combustion equipment, life support systems and safety devices) in which exceptional quality and reliability are required, or if the failure or malfunction of the products may directly jeopardize life or harm the human body.
  - Any applications other than the standard applications intended.
- (4) The products and product specifications described in this book are subject to change without notice for modification and/or improvement. At the final stage of your design, purchasing, or use of the products, therefore, ask for the most up-to-date Product Standards in advance to make sure that the latest specifications satisfy your requirements.
- (5) When designing your equipment, comply with the range of absolute maximum rating and the guaranteed operating conditions (operating power supply voltage and operating environment etc.). Especially, please be careful not to exceed the range of absolute maximum rating on the transient state, such as power-on, power-off and mode-switching. Otherwise, we will not be liable for any defect which may arise later in your equipment.
  - Even when the products are used within the guaranteed values, take into the consideration of incidence of break down and failure mode, possible to occur to semiconductor products. Measures on the systems such as redundant design, arresting the spread of fire or preventing glitch are recommended in order to prevent physical injury, fire, social damages, for example, by using the products.
- (6) Comply with the instructions for use in order to prevent breakdown and characteristics change due to external factors (ESD, EOS, thermal stress and mechanical stress) at the time of handling, mounting or at customer's process. When using products for which damp-proof packing is required, satisfy the conditions, such as shelf life and the elapsed time since first opening the packages.
- (7) This book may be not reprinted or reproduced whether wholly or partially, without the prior written permission of our company.