

KA7524B

Power Factor Correction Controller

Features

- Internal self-starting
- Micro power start up mode
- Included under voltage lockout circuit
- Internal 1% reference
- High output current : Peak 500mA

Descripton

The KA7524B provides the necessary features to implement the Electronic BALLAST control and S.M.P.S application for designing on active power factor correction circuit.

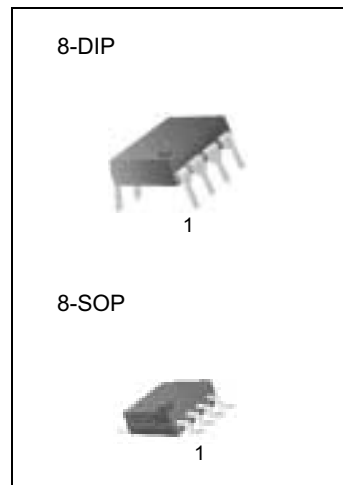

Internal Block Diagram

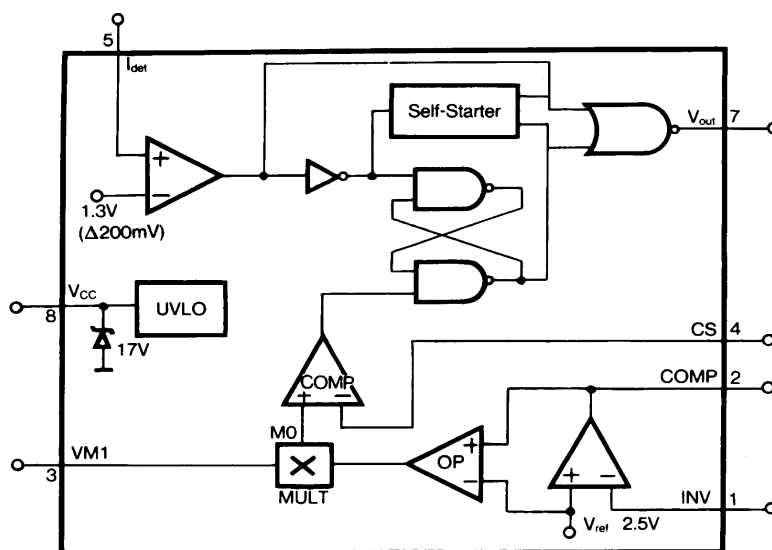

Connection Diagram

KA7524/KA7524D (8 DIP, 8 SOP)

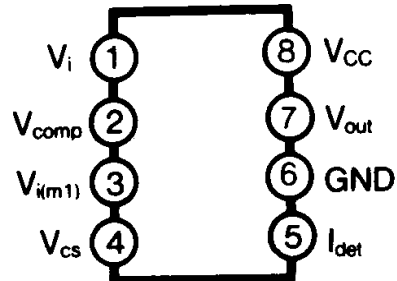

Absolute Maximum Ratings

Parameter	Symbol	Value	Unit
Supply Voltage	V_{CC}	20	V
Peak Driver Output Current	$I_{O(P)}$	500	mA
Detect Clamping Diode Current	I_{DET}	10	mA
Output Clamping Diode Current	$I_{O(C.D)}$	10	mA
Operating Ambient Temperature	T_{OPR}	-25 ~ + 100	-
Storage Temperature	T_{STG}	-65 ~ + 150	-

Electrical Characteristics

Parameter	Symbol	Conditions	Min.	Typ.	Max.	Unit
UNDER VOLTAGE LOCKOUT SECTION						
Start Threshold Voltage	V _{TH(ST)}	-	9.2	10	10.8	V
UV Lockout Hysteresis	V _{THS}	-	1.8	2.0	2.2	V
Supply Zener Voltage	V _Z	-	-	17	-	V
SUPPLY CURRENT SECTION						
Start-Up Supply Current	I _{START}	V _{CC} V _{TH}	-	0.25	0.5	mA
Operating Supply Current	I _{CC}	V _{CC} = 12V, No Load	-	6	12	mA
Dynamic Operating Current	I _{CC(D)}	V _{CC} = 12V, f = 50KHz, C _{GS} = 1000PF	-	10	20	mA
REFERENCE SECTION(NOTE1)						
Reference Voltage	V _{REF}	KA7524B/BD	2.475	2.5	2.525	V
Line regulation	V _{REF}	12VV _{CC} 16V	-	0.1	10	mV
Load Regulation	V _{REF}	0I _{REF} 2mA	-	0.1	10	mV
Temperature Stability	ST _T	-	-	20	-	mV
ERROR AMPLIFIER SECTION						
Input Offset Voltage	V _{IO}	-	-15	-	15	mV
Input Bias Current	I _{BIAS}	-	-1	-0.1	1	uA
Large Signal Open Loop Gain	G _V	-	60	100	-	dB
Power Supply Rejection Ratio	PSRR	-	60	86	-	dB
Output Current	I _{SOURCE}	-	2	-	-	mA
	I _{SINK}	-	-	-	-2	mA
Output Voltage Range	V _{O(P)}	-	1.2	-	4	V
Unity Gain Bandwidth	UBW	-	-	1.0	-	MHz
Phase Margin	MPH	-	-	57	-	-

Electrical Characteristics (Continued)

Parameter	Symbol	Conditions	Min.	Typ.	Max.	Unit
MULTIPLIER SECTION						
M1 Input Voltage Range	V _{I(M1)}	-	0	-	2	V
M2 Input Voltage Range	V _{I(M2)}	-	V _{REF}	-	V _{REF+1}	V
Input Bias Current	I _{BIAS}	-	-2	-0.5	2	uA
Multiplier Gain (Note2)	G _V	V _{I(M1)} = 0.5V, V _{I(M2)} = 3V	-	0.8	-	uA
Multiplier Gain Stability	ST _T	-	-	-0.2	-	/
CURRENT SENSE SECTION						
Input Offset Voltage	V _{IO}	-	-10	-	10	mV
Input Bias Current	I _{BIAS}	0V _{CS} 1.7V	-5	-	5	uA
C. Sense Delay to Output	t _{D(S)}	Error Amp Output = 3.7V	-	200	500	nS
CURRENT DETECT SECTION						
Input Voltage Threshold	V _{TH}	-	1.0	1.3	1.6	V
Hysteresis	V _{THS}	-	-	200	-	mV
Input Low Clamp Voltage	V _{IC(L)}	I _{DET} = 0mA	-	-	0.95	V
Input High Clamp Voltage	V _{IC(H)}	I _{DET} = 3mA	6.1	7.1	-	V
Input Current	I _J	0.9V _{DET} 6V	-	5	-	uA
Input Clamp Diode Current	I _{CD}	V _{DET} 0.9V, V _{DET} 6V	-	-	3	mA
CURRENT DETECT SECTION						
Output Voltage(High)	V _{O(H)}	I _O = -10mA, V _{CC} = 12V	7	9	-	V
Output Voltage(Low)	V _{O(L)}	I _O = 10mA, V _{CC} = 12V	-	0.8	1.8	V
Rising Time	t _R	CL = 1000pF	-	100	200	nS
Falling Time	t _F	CL = 1000pF	-	90	200	nS
SELF-STARTING SECTION						
Self-Starting Time	t _{SS}	-	12	-	-	uS

Notes :

- Reference can not be tested on the PKG
- $G_V = V_{O(M)} / (V_{I(M1)}V_{I(M2)} - V_{REF})$

KA7524B Application Circuit

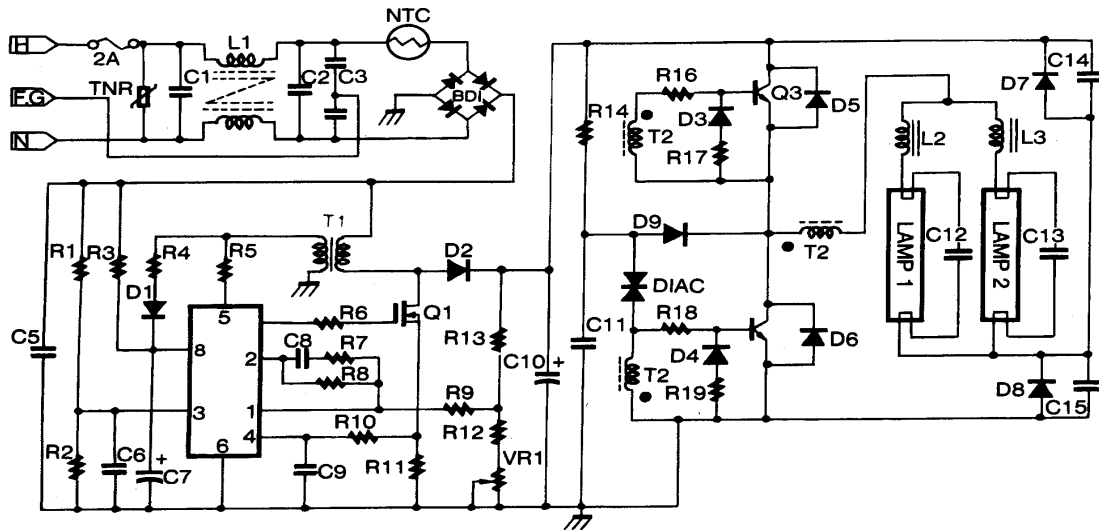

Part List

Resistor		Capacitor		Semiconductor	
R1	1.8M	C1	0.1uF	IC1	KA7524B
R2	10K	C2	0.1uF	Q1	IRF830
R3	100K	C3	4700pF	Q2	KSC5039
R4	3.3ohm	C4	4700pF	Q3	KSC5039
R5	22K	C5	0.1uF	D1	1N4004
R6	27ohm	C6	0.01uF	D2	1N4937
R7	2.2K	C7	100uF	D3	1N4148
R8	2.2M	C8	0.1uF	D4	1N4148
R9	150K	C9	3300pF	D5	FR107
R10	330ohm	C10	47uF/450V	D6	FR107
R11	0.75ohm	C11	0.1uF	D7	FR107
R12	5.1K	C12	3300pF	D8	FR107
R13	1M	C13	3300pF	BD1	PBP204
R14	390K	C14	0.01uF	TNR	12G471
R15	3.9M	C15	0.01uF	DIAIC	32V
R16	5.1ohm	Magnetics T1 EI-25 (PC30): P = 70T, S = 4T, Gap = 0.5mm T2 D15 (GP-5): P = 3T, S = 13T L1 EE-25 (Iron Power) 80mH L2, L3 EI-25 (PC30): 150T, Gap = 0.4mm			
R17	27ohm				
R18	5.1ohm				
R19	27ohm				
VR1	5K				
NTC	10ohm				

Mechanical Dimensions

Package

Dimensions in millimeters

8-DIP

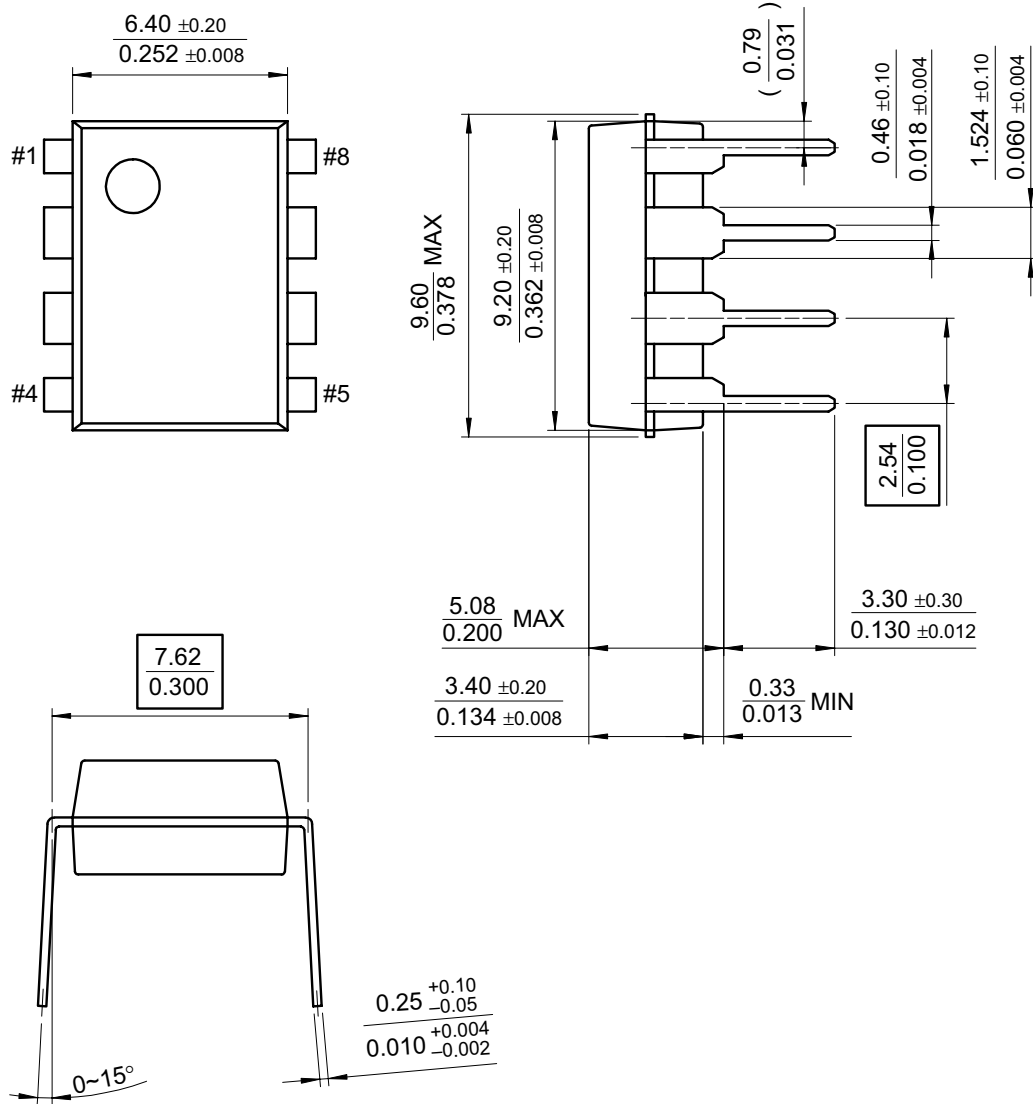

Mechanical Dimensions (Continued)

Package

Dimensions in millimeters

8-SOP

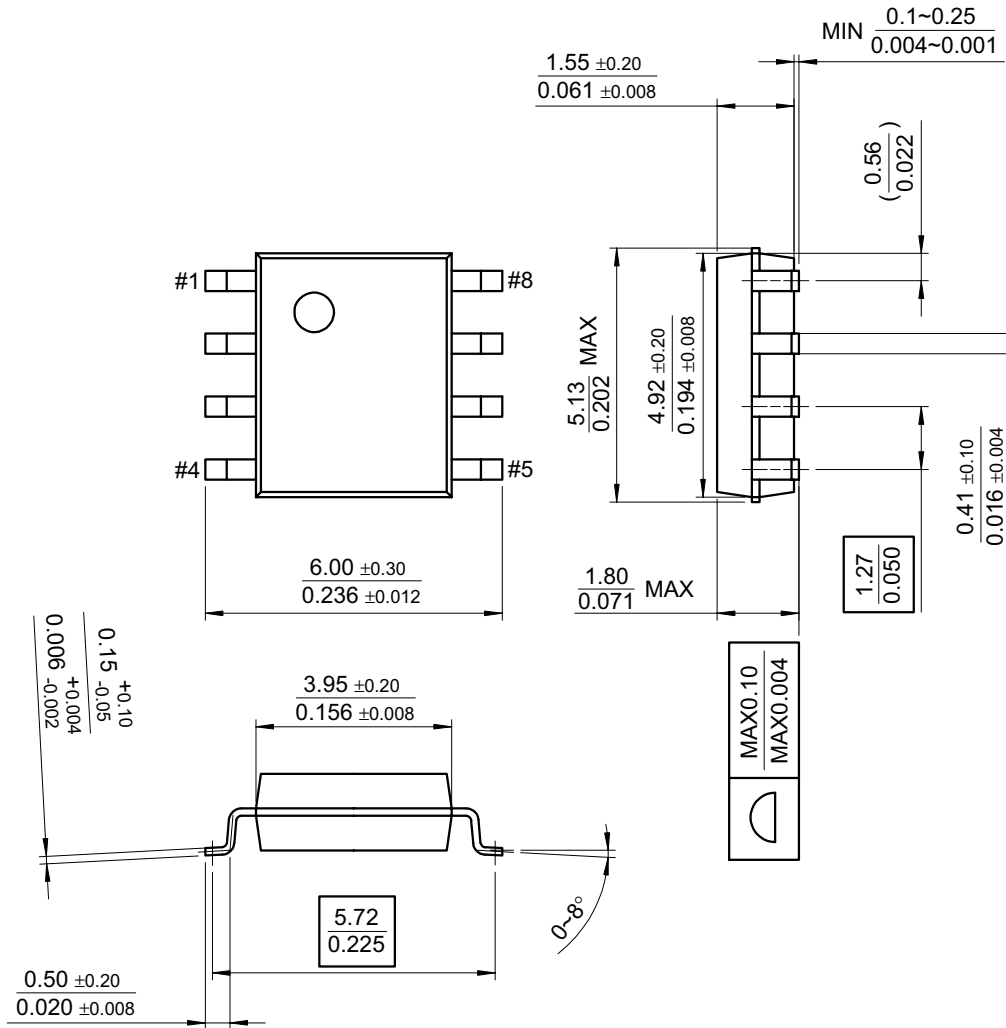

Ordering Information

Product Number	Package	Operating Temperature
KA7524B	8-DIP	-25°C ~ +100°C
KA7524BD	8-SOP	

DISCLAIMER

FAIRCHILD SEMICONDUCTOR RESERVES THE RIGHT TO MAKE CHANGES WITHOUT FURTHER NOTICE TO ANY PRODUCTS HEREIN TO IMPROVE RELIABILITY, FUNCTION OR DESIGN. FAIRCHILD DOES NOT ASSUME ANY LIABILITY ARISING OUT OF THE APPLICATION OR USE OF ANY PRODUCT OR CIRCUIT DESCRIBED HEREIN; NEITHER DOES IT CONVEY ANY LICENSE UNDER ITS PATENT RIGHTS, NOR THE RIGHTS OF OTHERS.

LIFE SUPPORT POLICY

FAIRCHILD'S PRODUCTS ARE NOT AUTHORIZED FOR USE AS CRITICAL COMPONENTS IN LIFE SUPPORT DEVICES OR SYSTEMS WITHOUT THE EXPRESS WRITTEN APPROVAL OF THE PRESIDENT OF FAIRCHILD SEMICONDUCTOR INTERNATIONAL. As used herein:

1. Life support devices or systems are devices or systems which, (a) are intended for surgical implant into the body, or (b) support or sustain life, and (c) whose failure to perform when properly used in accordance with instructions for use provided in the labeling, can be reasonably expected to result in a significant injury of the user.
2. A critical component in any component of a life support device or system whose failure to perform can be reasonably expected to cause the failure of the life support device or system, or to affect its safety or effectiveness.