

### POSITIVE VOLTAGE STABILIZED POWER SUPPLY

#### DESCRIPTION

The  $\mu$  PC305 is a high-performance stabilized power supply that can supply a constant voltage in a wide temperature range even if the input voltage or load voltage fluctuates, by integrating a high-gain error amplifier and a temperature-compensating constant-voltage diode on a single chip.

#### FEATURES

- Wide output voltage variable range:  $V_o = 4.5$  to  $30$  V,  $V_{DIF} = 3$  to  $30$  V
- Excellent load stability:  $0.02\%$
- Good ripple rejection ratio:  $0.003\%/V$

#### PIN CONFIGURATION (Top view)

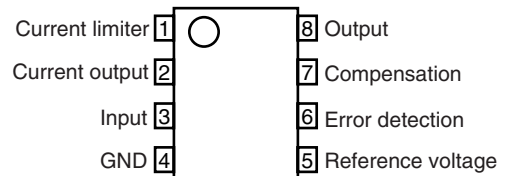

#### ORDERING INFORMATION

Part Number	Package
$\mu$ PC305G2	8-pin plastic SOP (5.72 mm (225) )

#### EQUIVALENT CIRCUIT

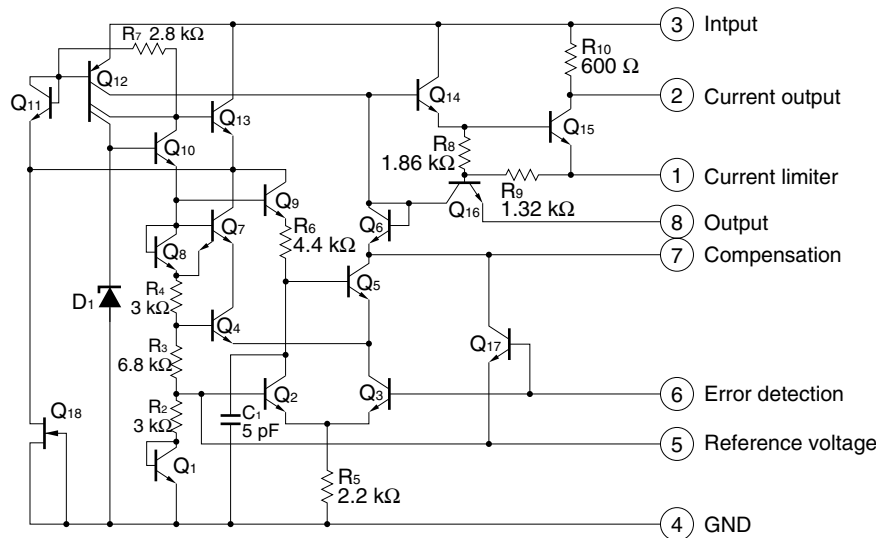

The information in this document is subject to change without notice. Before using this document, please confirm that this is the latest version.  
 Not all products and/or types are available in every country. Please check with an NEC Electronics sales representative for availability and additional information.

**ELECTRICAL SPECIFICATIONS**

**Absolute Maximum Ratings (T<sub>A</sub> = 25°C, unless otherwise specified.)**

Parameter	Symbol	Ratings	Unit
Input Voltage	V <sub>IN</sub>	-0.3 to +40	V
Input - Output Voltage Difference	V <sub>DIF</sub>	40	V
Maximum Output Current	I <sub>O</sub>	50	mA
Total Loss	P <sub>T</sub>	440 <sup>Note</sup>	mW
Operating Temperature	T <sub>A</sub>	0 to +70	°C
Storage Temperature	T <sub>stg</sub>	-55 to +125	°C

**Note** Where T<sub>A</sub> > 25°C, perform derating at T<sub>j</sub> = 125°C MAX., -4.4 mW/°C.

**Caution** Product quality may suffer if the absolute maximum rating is exceed even momentarily for any parameter. That is, the absolute maximum ratings are rated values at which the product is on the verge of suffering physical damage, and therefore the product must be used under conditions that ensure that the absolute maximum ratings are not exceed.

**Electrical Characteristics (T<sub>A</sub> = 25°C, unless otherwise specified.)**

Parameter	Symbol	Condition	MIN.	TYP.	MAX.	Unit
Input Voltage Range	V <sub>IN</sub>		8.0		40	V
Output Voltage Range	V <sub>OUT</sub>		4.5		30	V
Input - Output Voltage Difference	V <sub>DIF</sub>		3.0		30	V
Load Stability	REG <sub>L</sub>	0 ≤ I <sub>O</sub> ≤ 12 mA, R <sub>SC</sub> = 18 Ω		0.02	0.05	%
Input Stability	REG <sub>IN</sub>	V <sub>IN</sub> - V <sub>OUT</sub> ≤ 5 V		0.025	0.06	%/V
		V <sub>IN</sub> - V <sub>OUT</sub> > 5 V		0.015	0.03	%/V
Ripple Rejection Ratio	REJ	C <sub>REF</sub> = 10 μF, f = 120 Hz		0.003		%/V
Temperature Stability		0°C ≤ T <sub>A</sub> ≤ 70°C		0.3	1.0	%
Reference Voltage	V <sub>REF</sub>		1.65	1.8	1.90	V
Output Noise Voltage	V <sub>N</sub>	10 Hz ≤ f ≤ 10 kHz, C <sub>REF</sub> = 0 μF		0.005		%
		C <sub>REF</sub> = 0.1 μF		0.002		%
Long-time Stability				0.1		%
Supply Current under No Load	I <sub>CC</sub>	V <sub>IN</sub> = 40 V		1.0	2.0	mA

**Remark** R<sub>sc</sub>: Current-limiting resistor

C<sub>REF</sub>: Bypass capacitor of reference voltage pin

TYPICAL CHARACTERISTICS ( $T_A = 25^\circ\text{C}$ , unless otherwise specified. Reference values)

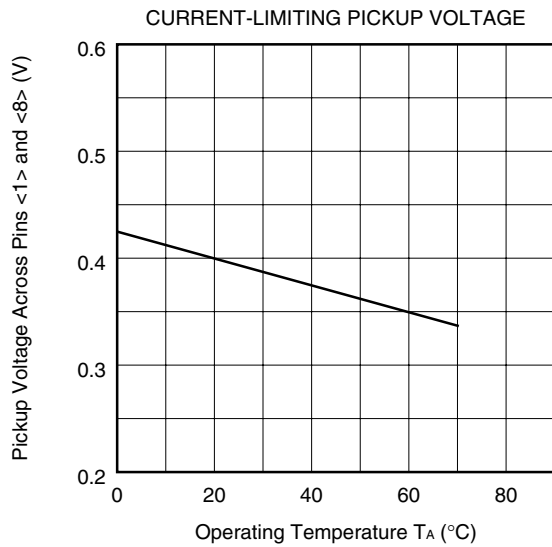
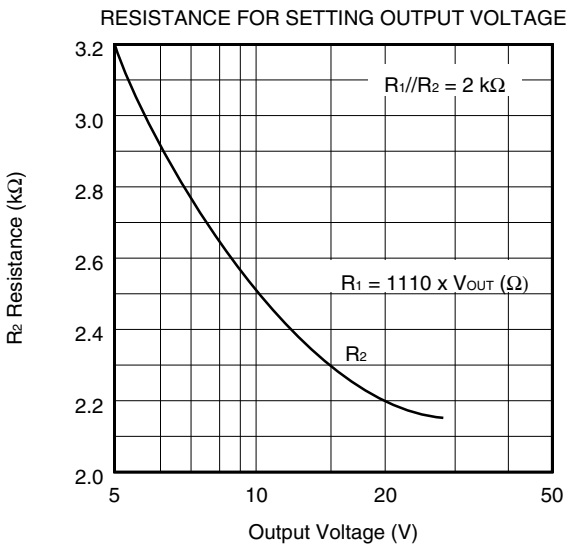
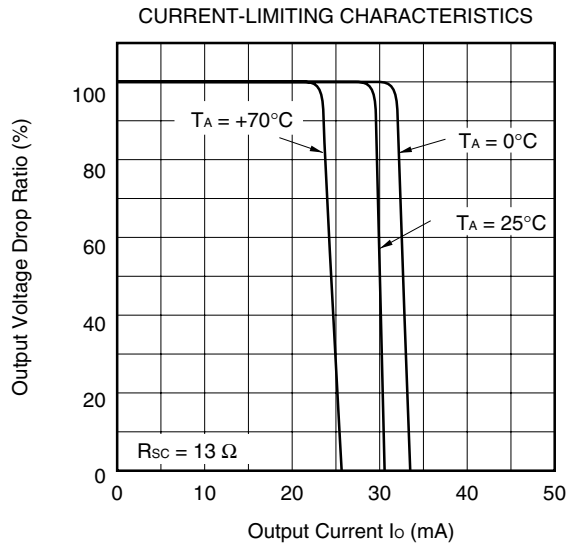
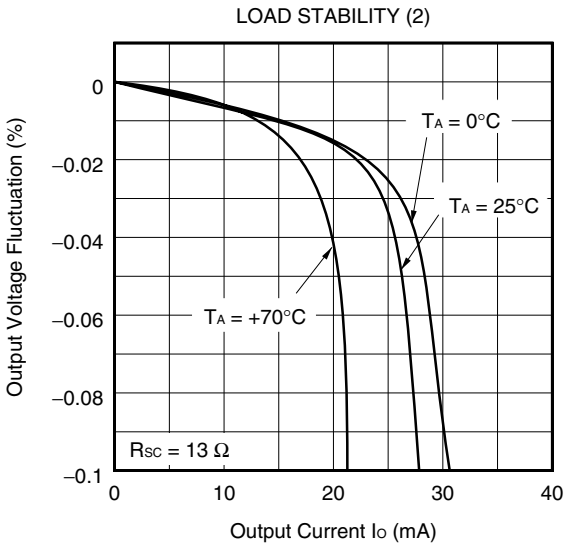
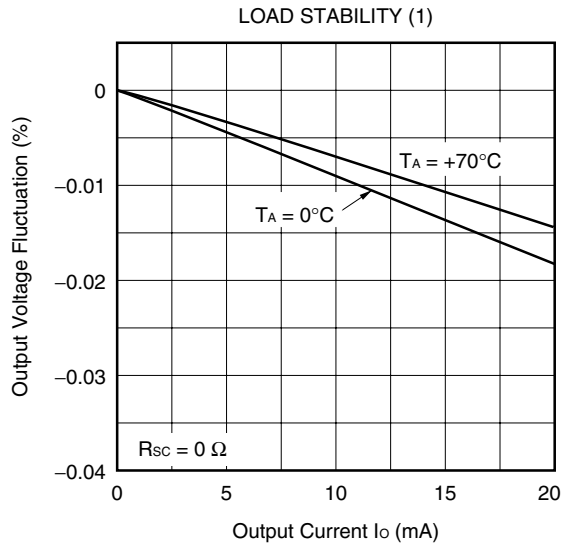
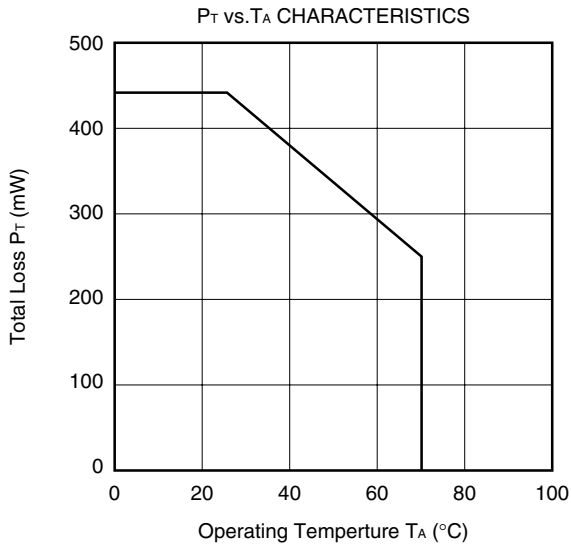

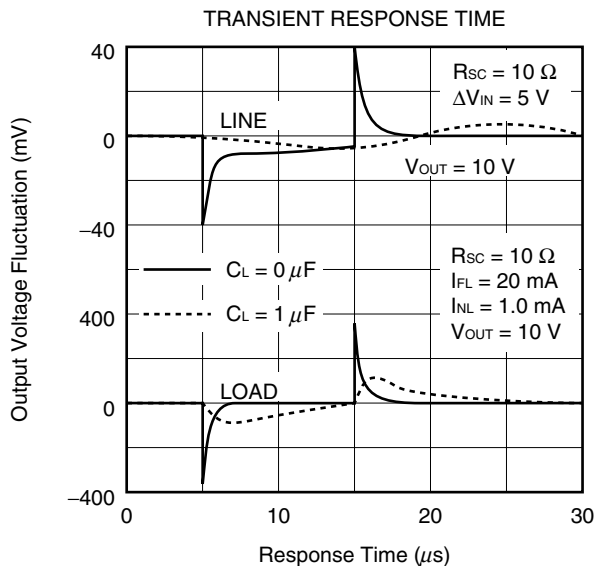
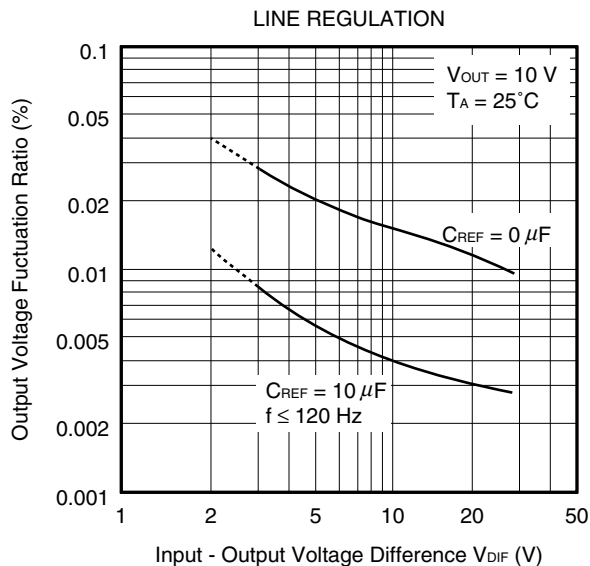

## APPLICATION CIRCUIT EXAMPLES

**5 V - 15 mA Regulator**

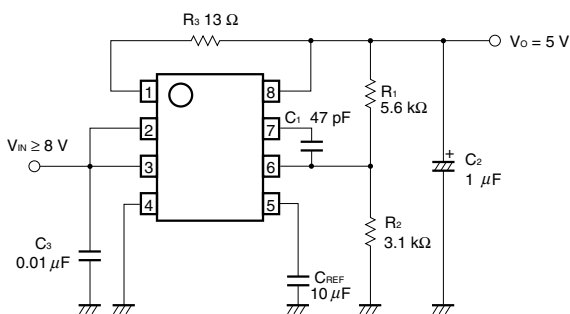

**10 V - 200 mA Regulator (Drooping Characteristics)**

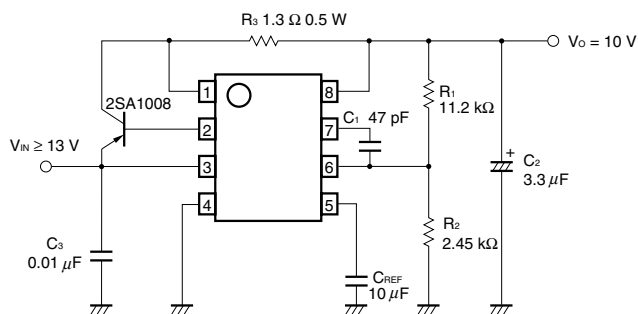

★ **15 V - 1 A Regulator (Fold-back Characteristics)**

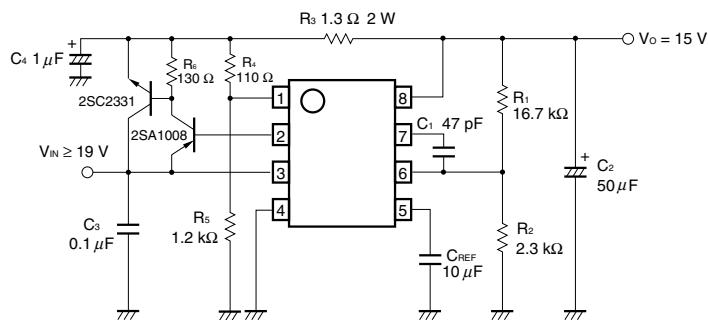

★ **1 A Constant-current Regulator**

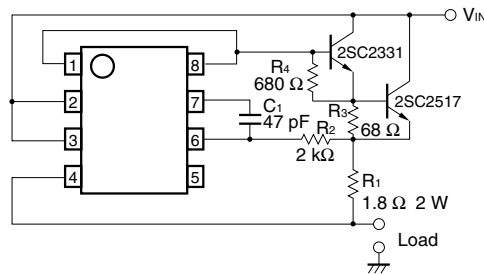

**Caution** Note the power consumption of the  $\mu$  PC305 when the output pin is short-circuited and that of the external transistor.

PACKAGE DRAWING

8-PIN PLASTIC SOP (5.72 mm (225))

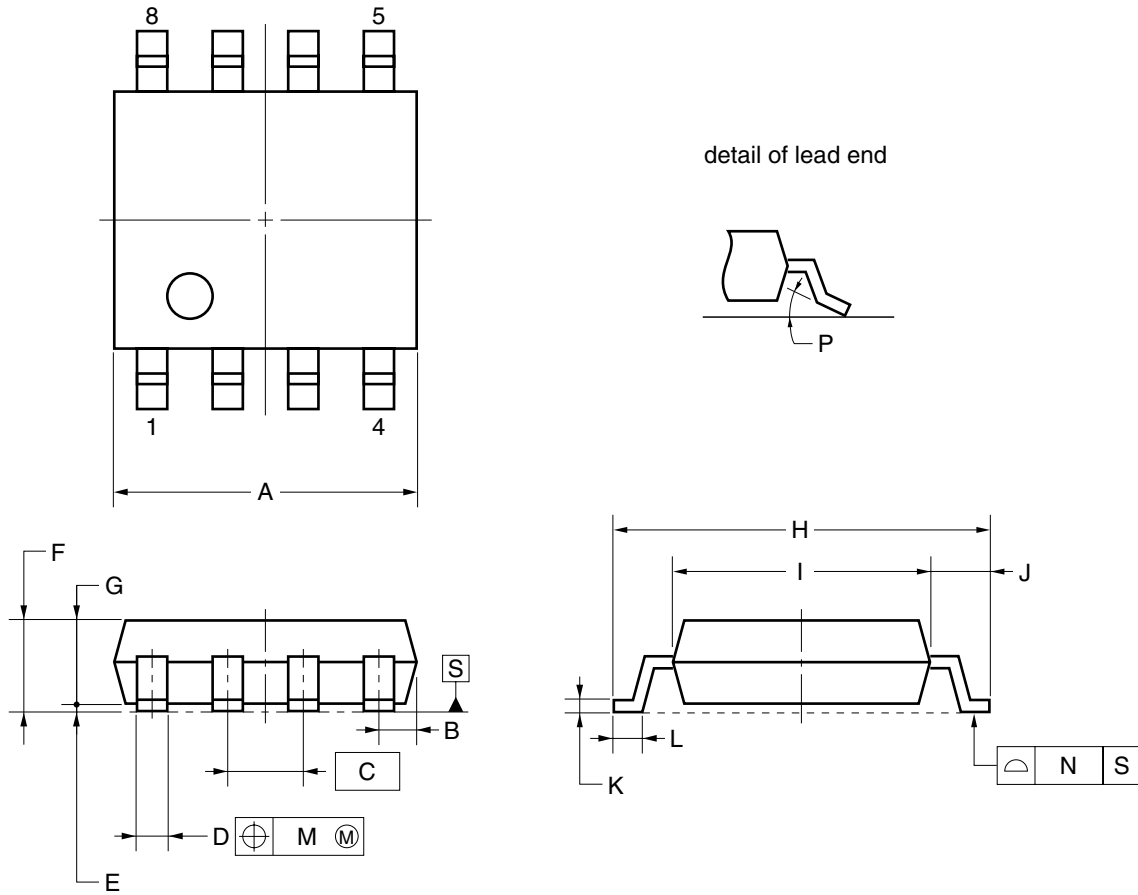

NOTE

Each lead centerline is located within 0.12 mm of its true position (T.P.) at maximum material condition.

ITEM	MILLIMETERS
A	5.2 <sup>+0.17</sup> / <sub>-0.20</sub>
B	0.78 MAX.
C	1.27 (T.P.)
D	0.42 <sup>+0.08</sup> / <sub>-0.07</sub>
E	0.1±0.1
F	1.59±0.21
G	1.49
H	6.5±0.3
I	4.4±0.15
J	1.1±0.2
K	0.17 <sup>+0.08</sup> / <sub>-0.07</sub>
L	0.6±0.2
M	0.12
N	0.10
P	3° <sup>+7°</sup> / <sub>-3°</sub>

S8GM-50-225B-6

★ RECOMMENDED SOLDERING CONDITIONS

The μ PC305 should be soldered and mounted under the following recommended conditions.

For soldering methods and conditions other than those recommended below, contact an NEC Electronics sales representative.

For technical information, see the following website.

**Semiconductor Device Mount Manual (<http://www.necel.com/pkg/en/mount/index.html>)**

**Type of Surface Mount Device**

μ PC305G2: 8-pin plastic SOP (5.72 mm (225) )

Process	Conditions	Symbol
Infrared reflow	Package peak temperature: 230°C, time: 30 sec MAX. (210°C MIN.), number of times: once	IR30-00-1
VPS	Package peak temperature: 215°C, time: 40 sec MAX. (200°C MIN.), number of times: once	VP15-00-1
Wave soldering	Solder bath temperature: 260°C MAX., time: 10 sec MAX., number of times: once, preheating temperature: 120°C MAX. (package surface temperature)	WS60-00-1

**Caution Do not use different soldering methods together (except for partial heating) .**

**★ REFERENCE DOCUMENTS**

Usage of Three-terminal Regulators (G12702E)

Quality Grades on NEC Semiconductor Devices (C11531E)

Review of Quality and Reliability Handbook (C12769E)

Semiconductor Selection Guide -Products and Packages- (X13769X)

• **The information in this document is current as of October, 2003. The information is subject to change without notice. For actual design-in, refer to the latest publications of NEC Electronics data sheets or data books, etc., for the most up-to-date specifications of NEC Electronics products. Not all products and/or types are available in every country. Please check with an NEC Electronics sales representative for availability and additional information.**

- No part of this document may be copied or reproduced in any form or by any means without the prior written consent of NEC Electronics. NEC Electronics assumes no responsibility for any errors that may appear in this document.
- NEC Electronics does not assume any liability for infringement of patents, copyrights or other intellectual property rights of third parties by or arising from the use of NEC Electronics products listed in this document or any other liability arising from the use of such products. No license, express, implied or otherwise, is granted under any patents, copyrights or other intellectual property rights of NEC Electronics or others.
- Descriptions of circuits, software and other related information in this document are provided for illustrative purposes in semiconductor product operation and application examples. The incorporation of these circuits, software and information in the design of a customer's equipment shall be done under the full responsibility of the customer. NEC Electronics assumes no responsibility for any losses incurred by customers or third parties arising from the use of these circuits, software and information.
- While NEC Electronics endeavors to enhance the quality, reliability and safety of NEC Electronics products, customers agree and acknowledge that the possibility of defects thereof cannot be eliminated entirely. To minimize risks of damage to property or injury (including death) to persons arising from defects in NEC Electronics products, customers must incorporate sufficient safety measures in their design, such as redundancy, fire-containment and anti-failure features.
- NEC Electronics products are classified into the following three quality grades: "Standard", "Special" and "Specific".

The "Specific" quality grade applies only to NEC Electronics products developed based on a customer-designated "quality assurance program" for a specific application. The recommended applications of an NEC Electronics product depend on its quality grade, as indicated below. Customers must check the quality grade of each NEC Electronics product before using it in a particular application.

"Standard": Computers, office equipment, communications equipment, test and measurement equipment, audio and visual equipment, home electronic appliances, machine tools, personal electronic equipment and industrial robots.

"Special": Transportation equipment (automobiles, trains, ships, etc.), traffic control systems, anti-disaster systems, anti-crime systems, safety equipment and medical equipment (not specifically designed for life support).

"Specific": Aircraft, aerospace equipment, submersible repeaters, nuclear reactor control systems, life support systems and medical equipment for life support, etc.

The quality grade of NEC Electronics products is "Standard" unless otherwise expressly specified in NEC Electronics data sheets or data books, etc. If customers wish to use NEC Electronics products in applications not intended by NEC Electronics, they must contact an NEC Electronics sales representative in advance to determine NEC Electronics' willingness to support a given application.

(Note)

- (1) "NEC Electronics" as used in this statement means NEC Electronics Corporation and also includes its majority-owned subsidiaries.
- (2) "NEC Electronics products" means any product developed or manufactured by or for NEC Electronics (as defined above).