

Silicon PNP Power Transistors

2SA957 2SA958

DESCRIPTION

- With TO-220 package
- High breakdown voltage
- High power dissipation

APPLICATIONS

- For general purpose applications

PINNING

PIN	DESCRIPTION
1	Emitter
2	Collector;connected to mounting base
3	Base

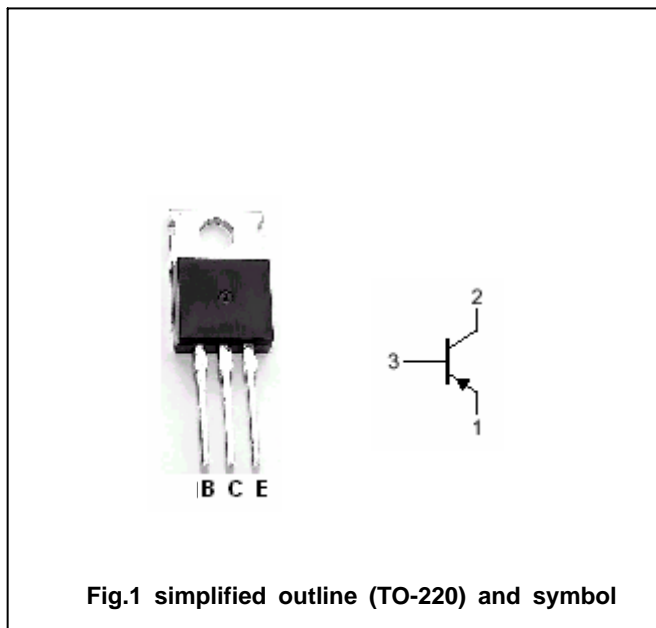

Fig.1 simplified outline (TO-220) and symbol

Absolute maximum ratings(Ta=25)

SYMBOL	PARAMETER	CONDITIONS	VALUE	UNIT
V _{CBO}	Collector-base voltage	2SA957	-150	V
		2SA958	-200	
V _{CEO}	Collector-emitter voltage	2SA957	-150	V
		2SA958	-200	
V _{EBO}	Emitter-base voltage	Open collector	-6	V
I _C	Collector current		-2.0	A
I _B	Base current		-1.0	A
P _T	Total power dissipation	T _C =25	30	W
T _j	Junction temperature		150	
T _{stg}	Storage temperature		-55~150	

Silicon PNP Power Transistors

2SA957 2SA958

CHARACTERISTICS

T_j=25 unless otherwise specified

SYMBOL	PARAMETER	CONDITIONS	MIN	TYP.	MAX	UNIT
V _{CEO(BR)}	Collector-emitter breakdown voltage	2SA957	I _C =-25mA, I _B =0			V
		2SA958				
V _{CEsat}	Collector-emitter saturation voltage	I _C =-0.7A; I _B =-0.07A			-1.5	V
I _{CBO}	Collector cut-off current	2SA957				μA
		2SA958				
I _{EBO}	Emitter cut-off current	V _{EB} =-6V; I _C =0			-1.0	mA
h _{FE}	DC current gain	I _C =-0.7A; V _{CE} =-10V	40			
f _T	Transition frequency	I _C =-0.2A; V _{CE} =-12V		20		MHz
Switching times resistive load						
t _r	Rise time	I _C =-1.0A I _{B1} =- I _{B2} =-0.1A R _L =20 Ω; V _{CC} =-20V		0.4		μs
t _s	Storage time			1.5		μs
t _f	Fall time			0.5		μs

PACKAGE OUTLINE

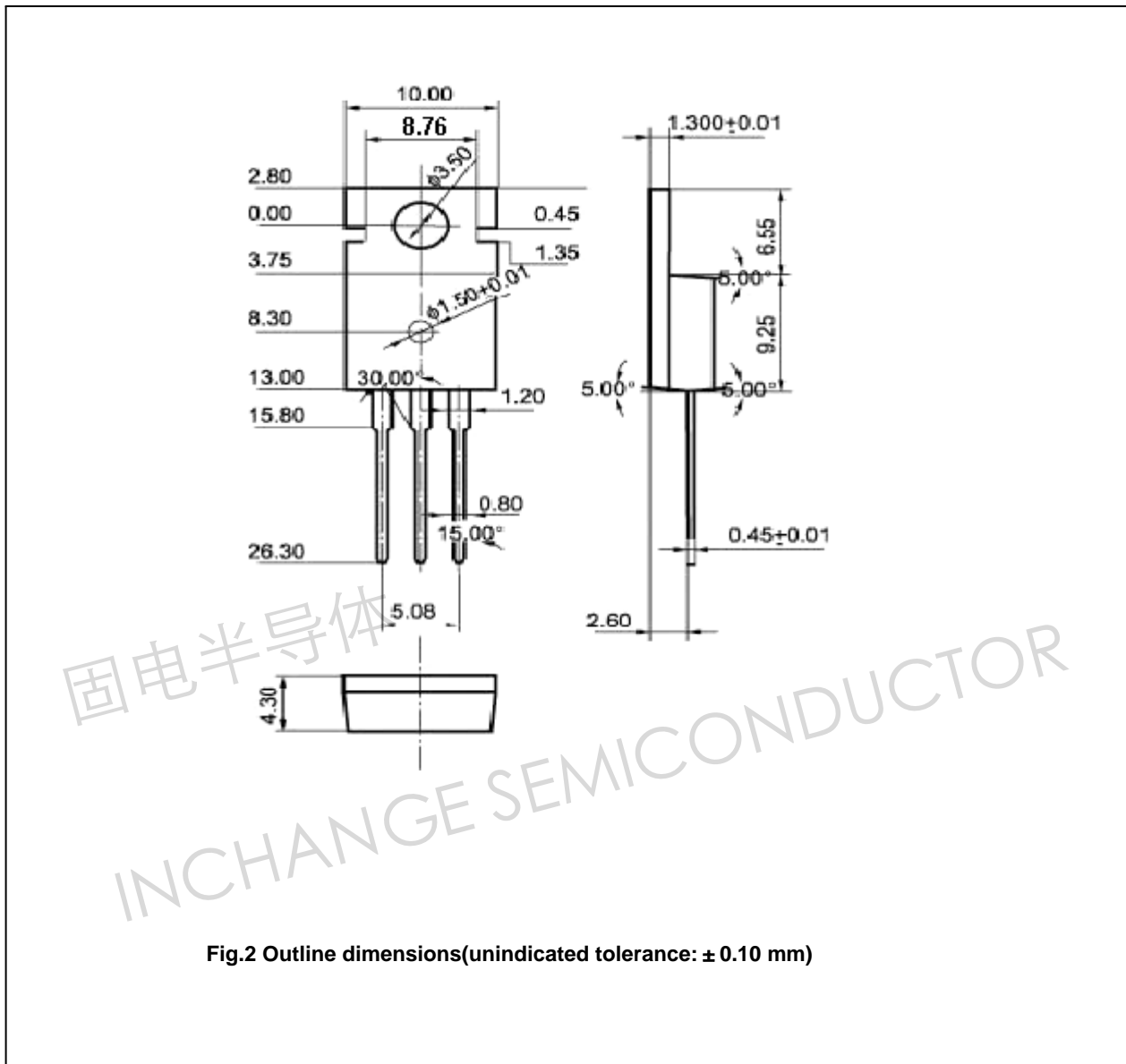

Fig.2 Outline dimensions(unindicated tolerance: ± 0.10 mm)